

HITACHI REMOTE OPERATOR

WOP

INSTRUCTION MANUAL

Thank you for purchasing WOP. This instruction manual is written about how to use WOP. You could use this manual for inspection, maintenance, setting and use it with the main body of inverter. After reading this manual, keep it at hand for future reference.

Request to the Dealer:
Please be sure to hand this manual over to the user without fail.

NT902X

HITACHI

SAFETY

To get best performance with **WOP**, read this manual and all of the warning sign attached to the inverter carefully before installation and operation, and follow the instructions exactly. Keep this manual handy for your quick reference.

Definitions and Symbols

A safety instruction (message) is given with a hazard alert symbol and a signal word; **WARNING** or **CAUTION**. Each signal word has the following meaning throughout this manual.



This symbol means hazardous high voltage. It used to call your attention to items or operations that could be dangerous to your and/or other persons operating this equipment. Read these messages and follow these instructions carefully.



This is the "Safety Alert Symbol". This symbol is used to call your attention to items or operations that could be dangerous to your and/or other persons operating this equipment. Read the messages and follow these instructions carefully.

WARNING



WARNING

Indicates a potentially hazardous situation which, if not avoided, can result in serious injury or death.



CAUTION

CAUTION

Indicates a potentially hazardous situation which, if not avoided, can result in minor to moderate injury, or serious damage of product.

The matters described under  **CAUTION** may, if not avoided, lead to serious results depending on the situation. Important matters are described in **CAUTION** (as well as **WARNING**), so be sure to observe them.

NOTE

NOTE

Notes indicate an area or subject of special merit, emphasizing either the product's capabilities or common errors in operation or maintenance.



HAZARDOUS HIGH VOLTAGE

Motor control equipment and electronic controllers are connected to hazardous line voltages. When servicing drives and electronic controllers, there might be exposed components with cases or protrusions at or above line potential. Extreme care should be taken to protect against shock.

Stand on an insulating pad and make it a habit to use only one hand when checking components. Always work with another person in case an emergency occurs. Disconnect power before checking controllers or performing maintenance. Be sure equipment is properly grounded. Wear safety glasses whenever working on electronic controllers or rotating electrical equipment.

SAFETY PRECAUTIONS

WARNING

Never modify the unit.
Otherwise, there is a danger of electric shock and/or injury.

CAUTION

Avoid locations of high temperatures, high humidity, dew condensation, dust, corrosive gases, explosive gases, combustible gases, coolant mist and sea damage etc. Install indoors, to avoid direct sunlight and the unit should be well ventilated.

Otherwise, there is a danger of electric shock and/or injury.

Revision History Table

No.	Revision Contents	The Date of Issue	Operation Manual No.
1	Initial Release	2010/4	NT902X

- The content of this manual are subject to change for improvement without notice.
- Please preserve this manual carefully since it will not reissued.
- It is prohibited to reprint part or the manual without permission.
- Please contact us if there is an emergency mistake, a leakage, etc. or there is a suspicious point was made though the content of this manual.

TABLE OF CONTENTS

Chapter 1	Introduction	1
1.1	Main Features	1
1.2	Unpacking and Inspection.....	1
1.3	Request upon asking	1
1.4	Warranty for the unit	1
Chapter 2	Name of parts and contents	2
2.1	Name of parts and contents	2
2.2	Operation key	3
2.3	LCD display	4
2.4	Connect to former type inverters.....	5
Chapter 3	Connection, wiring, and attaching	6
Chapter 4	Operation	7
4.1	The way of changing display mode.....	7
4.2	Operation of Monitor mode A.....	9
4.3	Operation of Monitor mode B.....	10
4.4	Operation of Function mode.....	11
4.5	Operation of Trip mode	12
4.6	Operation of Option mode.....	13
4.7	Details of Option mode.....	14
Chapter 5	Read, Write function and operation.....	15
5.1	R/W Storage Mode: Single · READ function	15
5.2	R/W Storage Mode: Single · WRITE function	16
5.3	R/W Storage Mode: Quad · READ function	17
5.4	R/W Storage Mode: Quad · VERIFY function	19
5.5	R/W Storage Mode: Quad · WRITE function.....	20
5.6	Operation condition of read and write function	20
Chapter 6	Inverter setting concerning WOP.....	21
Chapter 7	Error message	22
Chapter 8	Trouble shooting	23
Chapter 9	Specification.....	24

Chapter 1 Introduction

1.1 Main Features

WOP features state-of-the-art components and functions to provide user-friendly interface. WOP can connect to WJ200 inverter and has 5-line display that shows parameters by function code and by name. This allows you to operate the inverter remotely, via a cable (part no. ICS-1 or ICS-3, ICS-5, 1m or 3m, 5m).

It has an additional capability of reading a parameter setting and EzSQ program in the inverter into the memory. Then you can connect the copy unit on another inverter and write the parameter setting and EzSQ program into that inverter.

It can connect to former inverters like a SRW-OJ or SRW-OEX where some functions are restricted. Please see Tab. 1.

Tab. 1 Available Connecting Inverters

Inverters	DISPLAY	Mounting on Inverter	Remarks
WJ200-****2 series	22 characters×5 lines	N/A	Multi-Language
X200 series	16 characters×1 lines	N/A	English Only
SJ700 series	16 characters×2 lines	A	English Only

1.2 Unpacking and Inspection

Please take a few moments to unpack your new WOP and perform these steps:

- (1) Look for any damage that may have occurred during shipping.
- (2) Verify the contents of the box including WOP (with built-in battery) and one quick reference guide.
- (3) Inspect the name plate and make sure it matches the product part number you ordered.

1.3 Request upon asking

To receive technical support for WOP you purchased, contact the Hitachi inverter dealer from you purchased the operator, or the sales office or factory. Please be prepared to provide the following nameplate information:

- (1) Model
- (2) Serial Number (S/N.)
- (3) Date of purchase
- (4) Symptoms of any problem

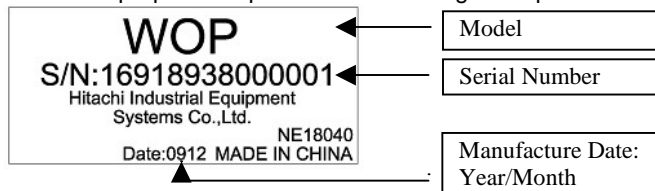

To reduce unpredictable downtime, we recommend that you stock a spare WOP.

1.4 Warranty for the unit

The warranty period under normal installation and handling conditions shall be one year from the purchase date, or two years from the date of manufacture, whichever occurs first. The warranty shall not cover coin type lithium battery built-in. The warranty shall cover replacement of WOP, at Hitachi's sole discretion.

Service in following cases, even in warranty period, shall be charged to the purchased.

- (1) Malfunction or damaged caused by mis-operation or modification or improper repair
- (2) Malfunction or damaged caused by a drop after purchase and transportation
- (3) Malfunction or damaged caused by fire, earthquake, flood, lightning, abnormal input voltage, contamination, or other natural disasters.

The warranty covers WOP only. Any damage caused to third party equipment by malfunction of the remote operator is not covered by the warranty.

Chapter 2 Name of parts and contents

2.1 Name of parts and contents

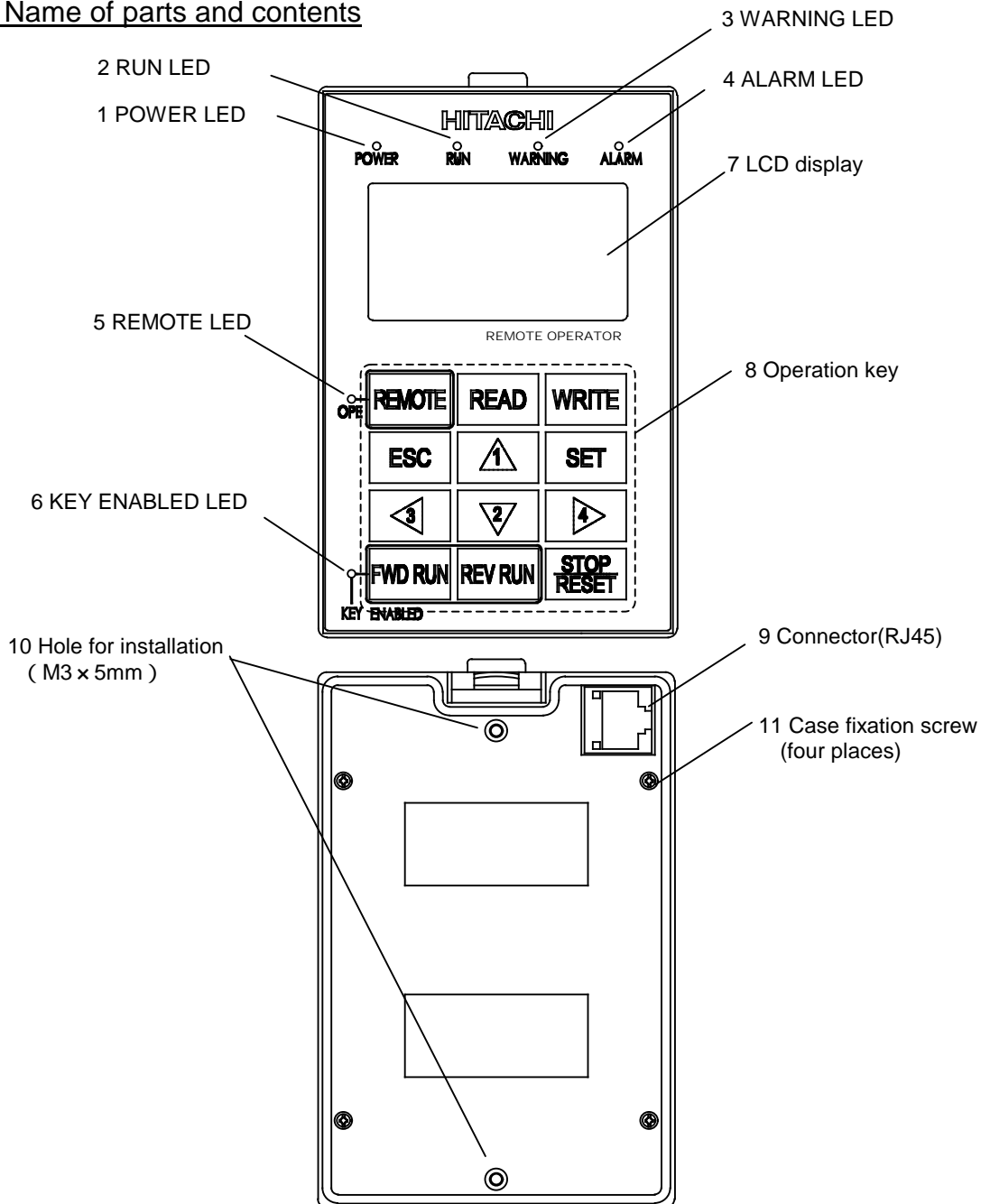

Tab 2 Name of parts and contents

NO.	Name of parts	Color	Contents
1	POWER LED	Green	Light on when power is supplied to the operator.
2	RUN LED	Green	Light on when the Inverter is running.
3	WARNING LED	Red	Light on when set value is incorrect.
4	ALARM LED	Red	Light on when the Inverter trips.
5	OPE LED	Green	Light on when the REMOTE key makes the compulsion operation function effective. It doesn't light when the compulsion operation function is effective by input terminal OPE. (Press the key more than 2s)
6	KEY ENABLED LED	Green	Light on only when operation command is set in operator.
7	LCD display		Please refer to page 4 for details.
8	Operation key		Please refer to Tab 3 for details.
9	Connector		It can be connected to the main body of the Inverter via a cable (optional).
10	Hole for installation		It is the hole for installation on the control panel. Please fix from the backside with the M3 screw.
11	Case fixation screw		Please unscrew these four screws and detach the case when exchanging the battery for clock IC.

2.2 Operation key

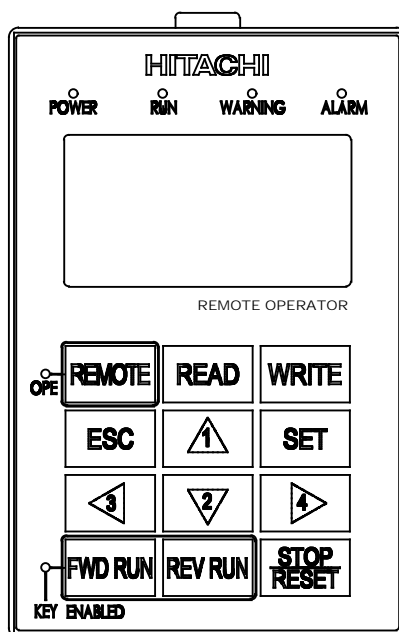

Tab 3 Name and function of operation key

NO.	Key Name	Function
1	REMOTE	Remote key can change operation command and frequency command method to the operator. Press the key more than 2 seconds, and can change to the operator, and quit from operator when press the key again.
2	READ	The key is used to transfer inverter parameters to the memory inside WOP. (Refer to chapter 5 for more details.)
3	WRITE	The key is used to copy the parameter set saved in WOP to inverter. (Refer to chapter 5 for more details.)
4	ESC	·Back to above layer. ·When at set mode, the change of set will be canceled and back to above layer via pressing the key.
5	SET	·Go ahead to below layer. ·When at edit layer, the change of set will be stored and back to above layer via pressing the key.
6	UP key (1)	·Cursor will move up, or function code will plus“1”. ·Value will plus“1” when press the key.
7	DOWN key (2)	·Cursor will move down, or function code will minus“1”. ·Value will minus“1” when press the key.
8	LEFT CURSOR key (3)	·The key is used to move left. ·It moves to the previous mode when the display is a navigation level.
9	RIGHT CURSOR key (4)	·The key is used to move right. ·It changes display mode from one to another when the display is at navigation level.
10	FWD RUN	Motor runs forward. The key is used for operating motor only when operation command (A002) is set in operator or the compulsion operation function effective. (Check KEY ENABLED LED, whether it flash or not.)
11	REV RUN	Motor runs reverse. The key is used for operating motor only when operation command (A002) is set in operator or the compulsion operation function effective. (Check KEY ENABLED LED, whether it flash or not.)
12	STOP/RESET	·The key is used to stop the motor, or reset an alarm. It is also possible to invalidate the STOP key when setting parameter. The key does not response when WOP reads or writes the parameters from or to inverter.

2.3 LCD display

Backlight

There are two kinds of backlight colors of LCD display, white and orange. And the state of the inverter is displayed by the difference of the color, as described in Tab 4.

Tab 4 Backlight colors of LCD display

Backlight Color	Contents
White	Normal (It is not related to inverter driving/stop)
Orange	Warning (Parameter mismatch)
White Orange (Alternate blinking for one second)	Trip (The same as ALARM LED)

The details of LCD display

The first line of LCD monitor always displays the display mode, the number for the control, the state of the inverter, and the display selection.

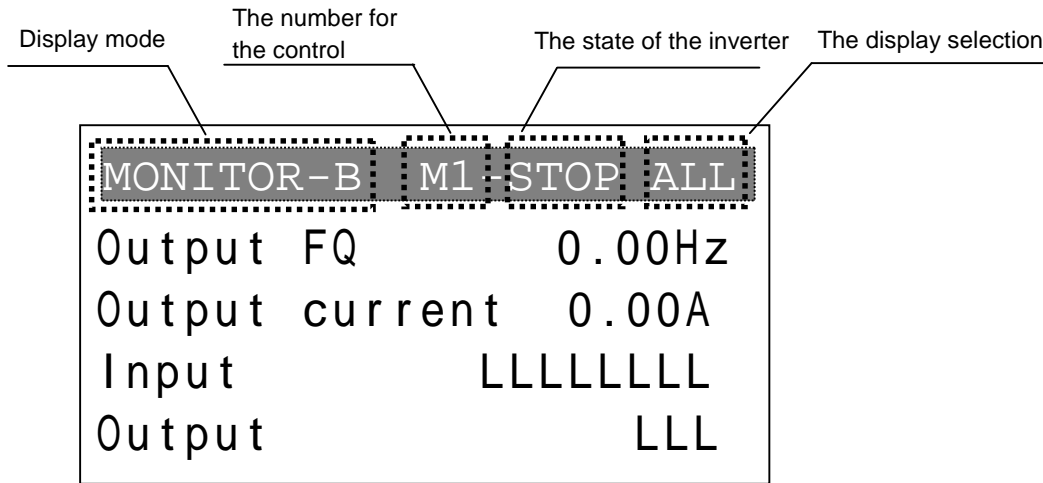

Fig 1 LCD display

Tab 5 The first line of LCD display

Item	Display character	Contents
Display mode	MONITOR-A	Monitor mode A
	MONITOR-B	Monitor mode B
	FUNCTION	Function mode
	TRIP	Trip mode
	WARNING	Warning mode(Alarm)
	OPTION	Option mode
The number for control (NOTE1)	M1	The first control object
	M2	The second control object. (SET is allocated to the input terminal and it switches.)
The state of inverter	STOP	Stopped
	FWD	Forward running
	REV	Reverse running
The display selection (b037)	ALL	Display all
	UTL	Each function display
	USR	User setting display
	CMP	Data compare display
	BAS	Basic display

NOTE: The number for the control is a motor number when two or more motors are switched and controlled.

2.4 Connect to former type inverters

Display contents and operation system of WOP are different depending on the inverter type connected. When WOP is connected to former-type inverters, it will display in the same way of former remote operators such as SRW-OJ and SRW-OEX, while the functions of key and LED are different, as described in Tab 6.

Note: former type inverters are SJ700 and X200series.

Tab 6 Difference with former inverter

KEY & LED of WOP	Connect to WJ200	Used at former inverter
REMOTE (Long push)	Compulsion operation function effective /invalid	
REMOTE (Short push)	(No response because of absence of the function)	Move to monitor mode (Monitor/MON key)
READ	Reading of parameter	Reading of parameter (Read/READ key)
WRITE	Writing of parameter	Writing of parameter (Copy/COPY key)
ESC	Back to the upper layer	Move to function mode (Function/FUN key)
SET	Store the setting value / Enter the lower layer	Store the setting value (Store/STR key)
POWER LED	Power on	
RUN LED	Inverter is running	
WARNING LED	Warning happened	(LED always turns off because of absence of the function)
ALARM LED	Inverter trip happened	
OPE LED	The compulsion operation function is effective by the operator	
KEY ENABLED LED	Operation command key is effective	

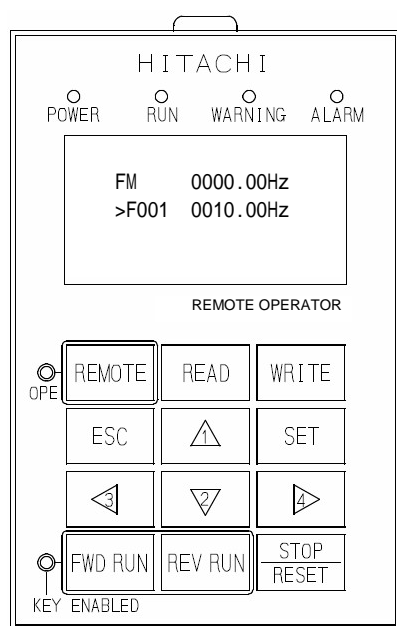

WOP

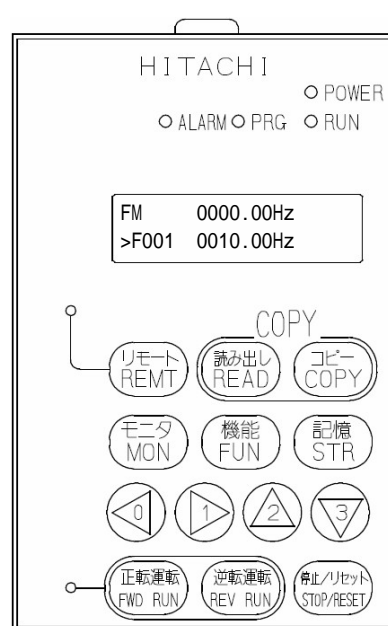

SRW-OJ

Chapter 3 Connection, wiring, and attaching

Please process the control panel as shown in a left figure below, and fix from the other side with M3 screw (5mm) when you install the operator on the control panel. Recommended torque is [0.9, 1.0] N.M.

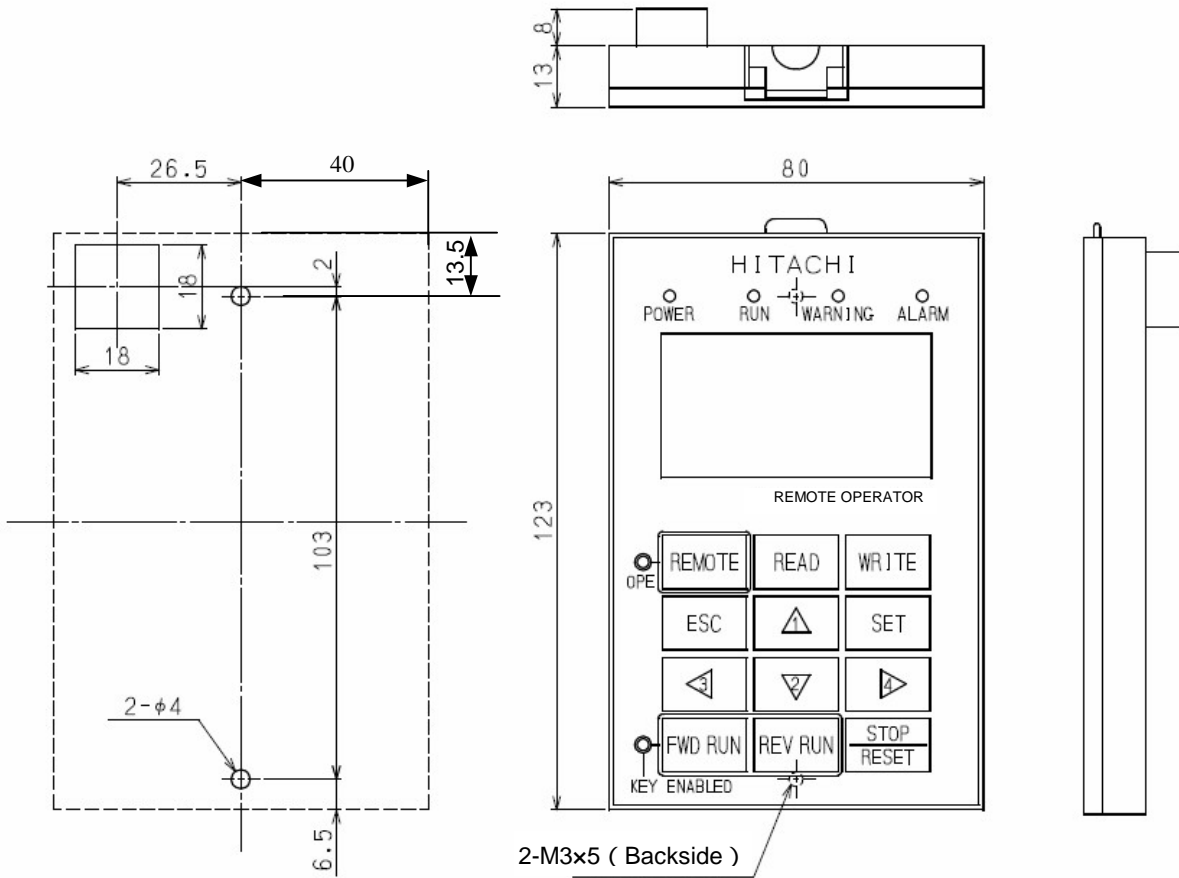

Recommended cable

Model	Content
ICS-1	1m cable
ICS-3	3m cable
ICS-5	5m cable

Make sure to use a straight cable within 5m in length and 10BASE-T category 5 (CAT5) of UTP or STP when the cable is prepared by the customer.

Note: UTP (Unshielded twist pair cable) , STP (Shielded twist pair cable)

Chapter 4 Operation

4.1 The way of changing display mode

WOP has four display modes which can be changed from one to another by pressing the [◀] or [▶] key at Navigation level. Moreover, there are 3 other modes called Read mode, Write mode and Option mode. In any display mode, it moves to Read mode or Write mode via [READ] key or [WRITE] key and moves to Option mode after pressing [◀], [△] and [▽] at the same time. It returns to display modes via [ESC] key.

Each mode has its own layers, where display contents and parameter settings cannot be changed at Navigation level while they can be changed at Edit layer. (Please see figure below.)

When pressing [SET] key at Navigation level, a cursor will appear and screen will move to below layer.

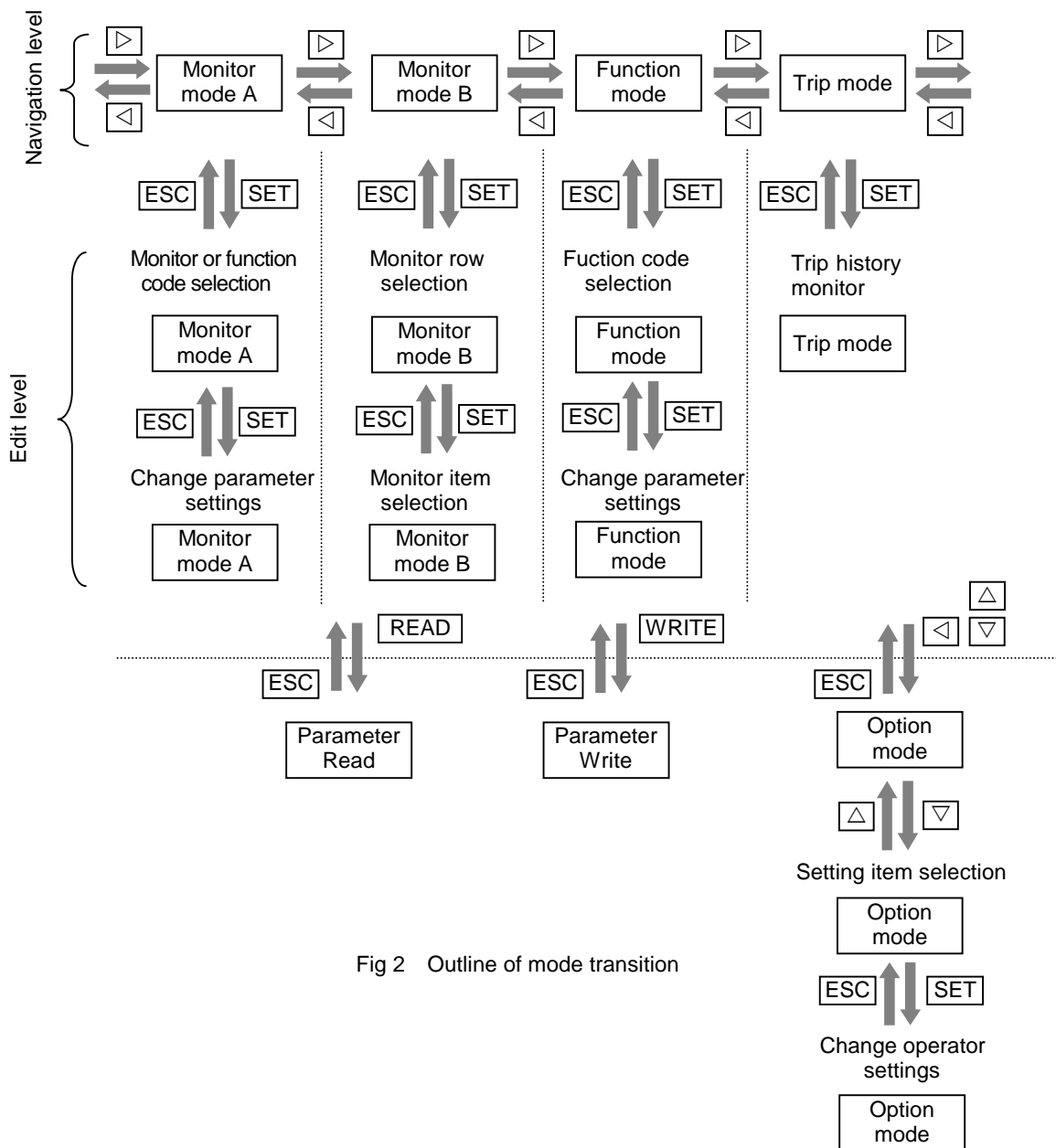
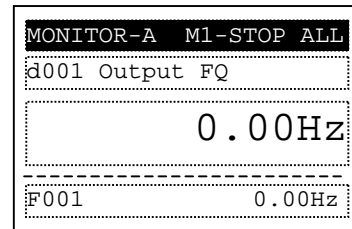

Fig 2 Outline of mode transition

The outline of each mode is shown as below.

Monitor mode A (Monitor + Setting)

The “d” group inverter parameters and “F-U” group inverter parameter can be displayed on the same screen in this mode. The content of “d” group parameter is displayed with big font characters. The function code such as “F001” and contents of “F-U” parameters are displayed, while function name of these parameters is not displayed.



Monitor mode B (Monitor x 4)

In this mode, for “d” group inverter parameters can be displayed at the same screen where function codes of these parameters are not displayed.

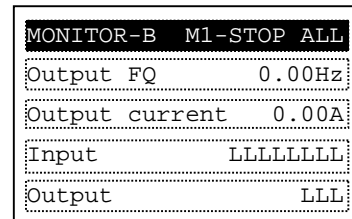

Function mode (setting)

In this mode, “F-U” group parameters can be displayed and set. Function code, function name, parameter content and parameter range are shown.

Note: “d” group inverter parameter cannot be set and displayed in this mode.

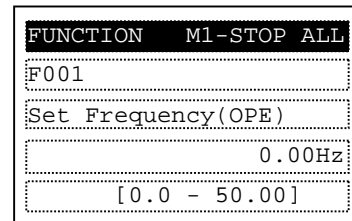

Trip mode

Trip information and warning information are displayed in this mode. When inverter trip or warning happens, the trip screen will compulsorily transitioned to from any display modes. In Option Mode, Read Mode and Write Mode, the LED or WARNING LED will light up.

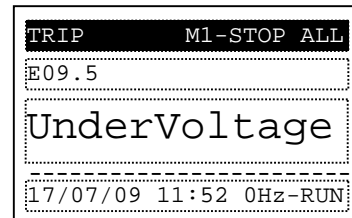

Option mode

Besides language selection, date and time setting, INV type selection, other configurations can also be set in this mode.

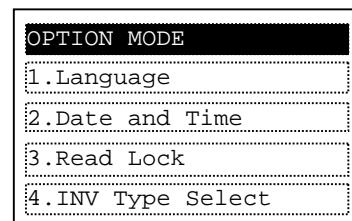

Initial display of WOP can be set via inverter parameter b038 when connecting to WJ200.

4.2 Operation of Monitor mode A

1. Please select monitor mode A by using the [◀] or [▶] key at the navigation layer. The cursor will not be displayed in the navigation layer until pressing the [SET] key.

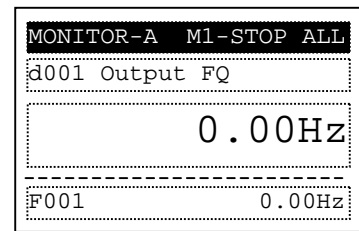

2. After pressing the [SET] key at navigation layer, it moves to the edit layer and the cursor appears at the monitor code part.

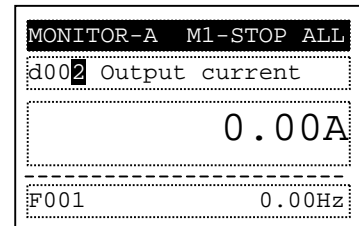

[Change of monitor item]: use the [△] or [▽] key to select the function code to display desired monitor item.

[Change of set item]: use the [◀] or [▶] key to move the cursor to the code part of function item (F001 as shown on figure) and use the [△] or [▽] key to change the function code.

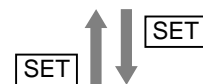
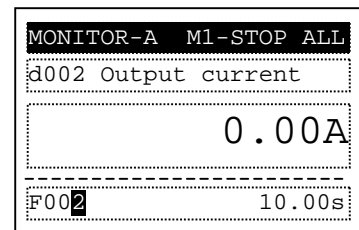

3. It enters the below layer after pressing the [SET] key and the cursor appears on the parameter part of a function item. Use the [△] or [▽] key to change data. It returns to the upper layer after storing parameter values via pressing the [SET] key. And the change is cancelled and returns to the upper layer via pressing the [ESC] key.

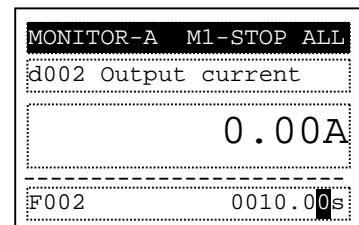

4.3 Operation of Monitor mode B

1. Please select monitor mode B by using the [◀] or [▶] key at the navigation layer. The cursor will not be displayed in this layer.

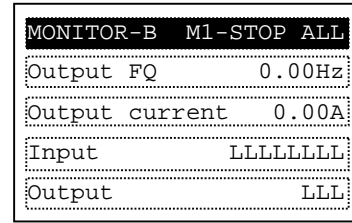

2. After pressing the [SET] key at navigation layer, it moves to the edit layer and the cursor appears at the first row of the monitor item. Use the [△] or [▽] key to select the row of monitor item.

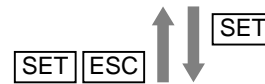
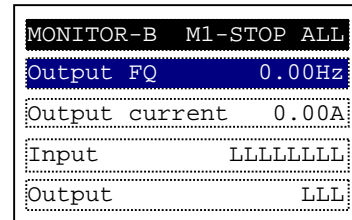

3. It enters the below layer after pressing the [SET] key and the cursor appears at the function code of the item. Use the [△] or [▽] key to select the code. After pressing the [SET] key, the monitor item is selected, and it returns to the upper layer. After pressing [ESC] key, the change is cancelled and returns to the upper layer where previous parameter will be displayed.

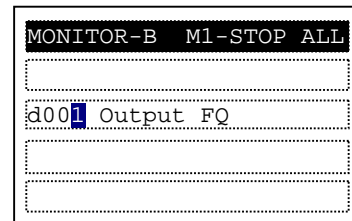

4.4 Operation of Function mode

1. Please select function mode by using the [◀] or [▶] key at the navigation level. The cursor is not displayed in this layer.

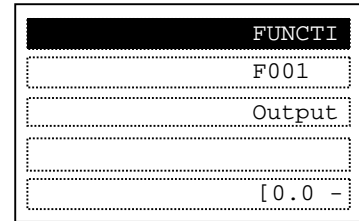

2. Press the [SET] key to move to the edit layer and the cursor appears in the function code. And use the [△] or [▽] key to select the item which be changed.

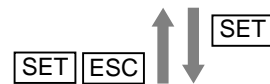
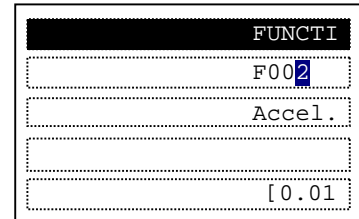

3. It enters the below layer after pressing the [SET] key and the cursor appears in the parameter part of a set item. Use the [△] or [▽] key to select the data which to be set. It returns to the upper layer after storing parameter values by pressing the [SET] key. The change is cancelled and returns to the upper layer by pressing the [ESC] key.

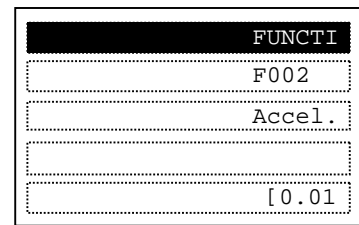

4.5 Operation of Trip mode

1. Use the [◀] or [▶] key to select trip mode at the navigation layer.

TRIP	M1-STOP ALL
E09.5	
UnderVoltage	
17/07/09 11:52 0Hz-RUN	

2. After pressing the [SET] key, the past trip information (6 times) and warning information (1 time) which are recorded in Inverter is displayed in the below layer. One time trip information is composed of two pages.

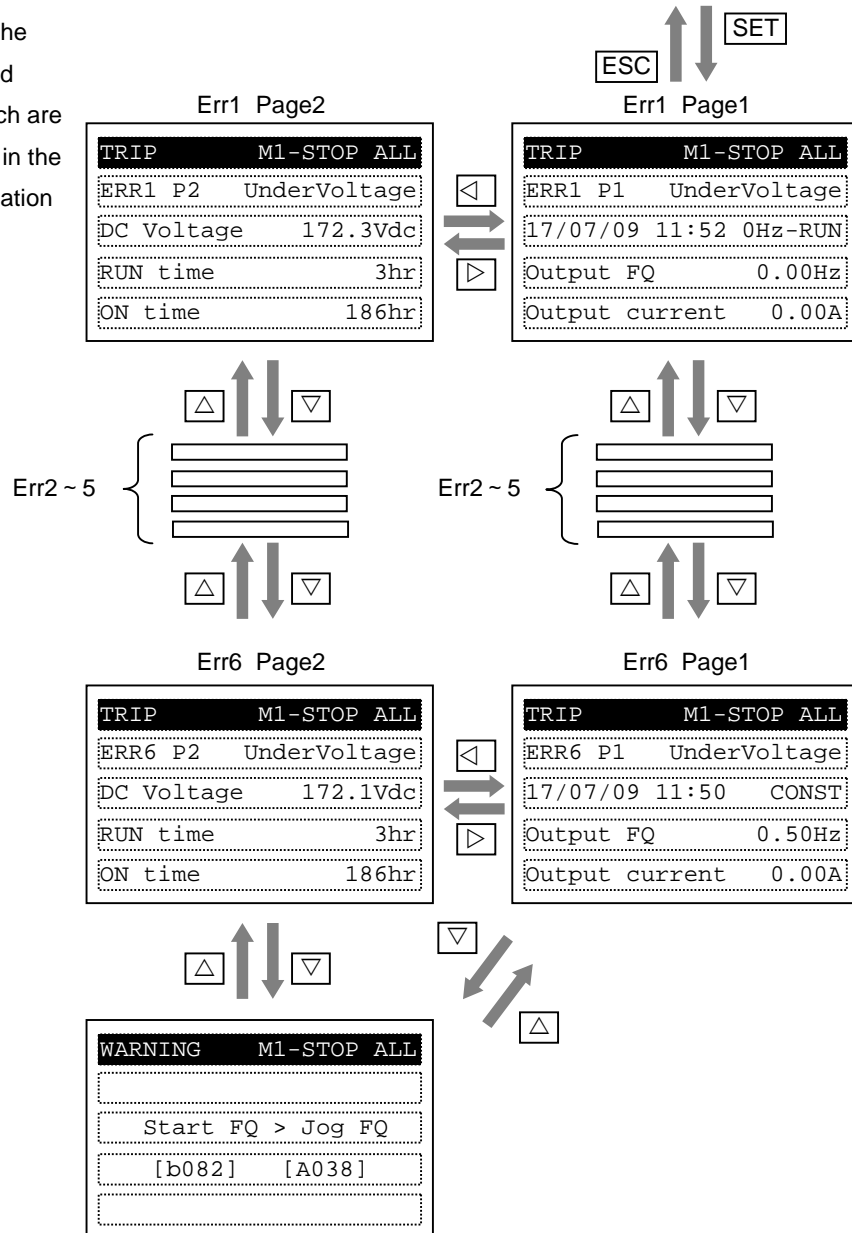

(NOTE): When trip happens, ALARM LED will be illuminated and the inverter can be reset via the [STOP/RESET] key.

4.6 Operation of Option mode

1. Please press the [◀], [△] and [▽] key at the same time to enter the OPTION MODE. The cursor will appear in the first row of the setting items and use the [△] or [▽] key to select the item. It returns to previous display after pressing the [ESC] key.

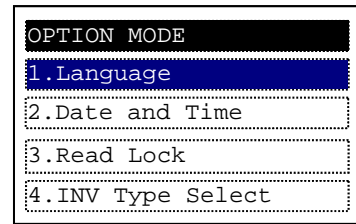

2. It enters the below layer after pressing the [SET] key and the cursor appears in the value part of a set item. Use the [△] or [▽] key to select the data to set. It returns to the upper layer after storing parameter values by pressing the [SET] key. The change is cancelled and returns to the upper layer by pressing the [ESC] key.

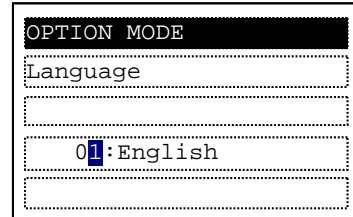

4.7 Details of Option mode

No.	Item	Content	Setting range	Default
1	Language	Setting language.	01: English (ENGLISH) 02: 日本語 (JAPANESE) 03: 中文 (CHINESE)	01
2	Date and Time	Setting date and time of WOP.	Date: 2000/1/1~2099/12/31 Time: 00:00 ~ 23:59 Format: 1~3	2009/01/01 00:00 1
3	Read Lock	Setting "Read lock" enable to disable the READ operation in order to protect the parameter saved in WOP from being overwritten.	01: Enable 02: Disable	02
4	INV Type Select	Please select correct INV type when using WOP, otherwise, "COM ERROR" will be displayed automatically.	01: Type 1(WJ200) 02: Type 2(X200, SJ700)	01
5	R/W Storage Mode	Setting the number of parameter sets of inverter for READ/WRITE mode. (Refer to chapter 5 for more details.)	01: Single 02: Quad	02
6	Backlight Auto-Off	When WOP remains idle (no key operations) for 1 minute, LCD backlight will be turned off automatically until any key is pressed. The Backlight Auto-Off function does not work when trip happened.	01: Off 02: 1 minute	01
7	Backlight Flicker	It turns on the Orange backlight.	01: Enable 02: Disable	01
8	Operator Reset	Using this function to return default settings of WOP. The follows items will be reset: 1) Language: English 2) Date and time: 2009/01/01 THU 00:00 3) Time format: 01:YY/MM/DD 4) Read lock: Disable 5) R/W Storage Mode: Quad 6) Backlight Auto-Off: Off 7) Backlight Flicker: Enable After reset operation, date and time setting is required.	01: YES 02: NO	02
9	Check Mode	Checking whether LED and key etc. are normal or not.	Key&Led Check, Lcd Check, EEPROM Check, RTC Check, Serial Loopback, Debug Mode, Firmware Version.	-

NOTE: Please do not execute the EEPROM Check. Otherwise, the data (parameters/EzSQ program) saved in WOP will be erased.

Chapter 5 Read, Write function and operation

WOP can read and save Inverter parameter settings, and copy them to another inverter

WOP can save four inverters' parameter sets or one inverter's parameter set and its EzSQ program. It can be selected via changing item of R/W Storage Mode in Option mode.

Note: If Read operation cannot be executed, please confirm whether the Read Lock in option mode is "02:Disable". Besides this, there are some possible restrictions caused by the parameter in Inverter. Please refer to section 5.6 for more details.

5.1 R/W Storage Mode: Single · READ function

When the R/W Storage Mode is selected to "01:Single", the parameter Read or Write is executed immediately after pressing [READ] or [WRITE] key. It is convenient to write the parameters to numerous inverters (the same type) continuously.

After pressing the [READ] key in any display mode except Write mode and Option mode, the parameter settings of the inverter are read and saved into WOP. EzSQ program read is transferred to WOP automatically after parameter reading is finished. If the inverter supports EzSQ function, it returns to previous display after read is completed.

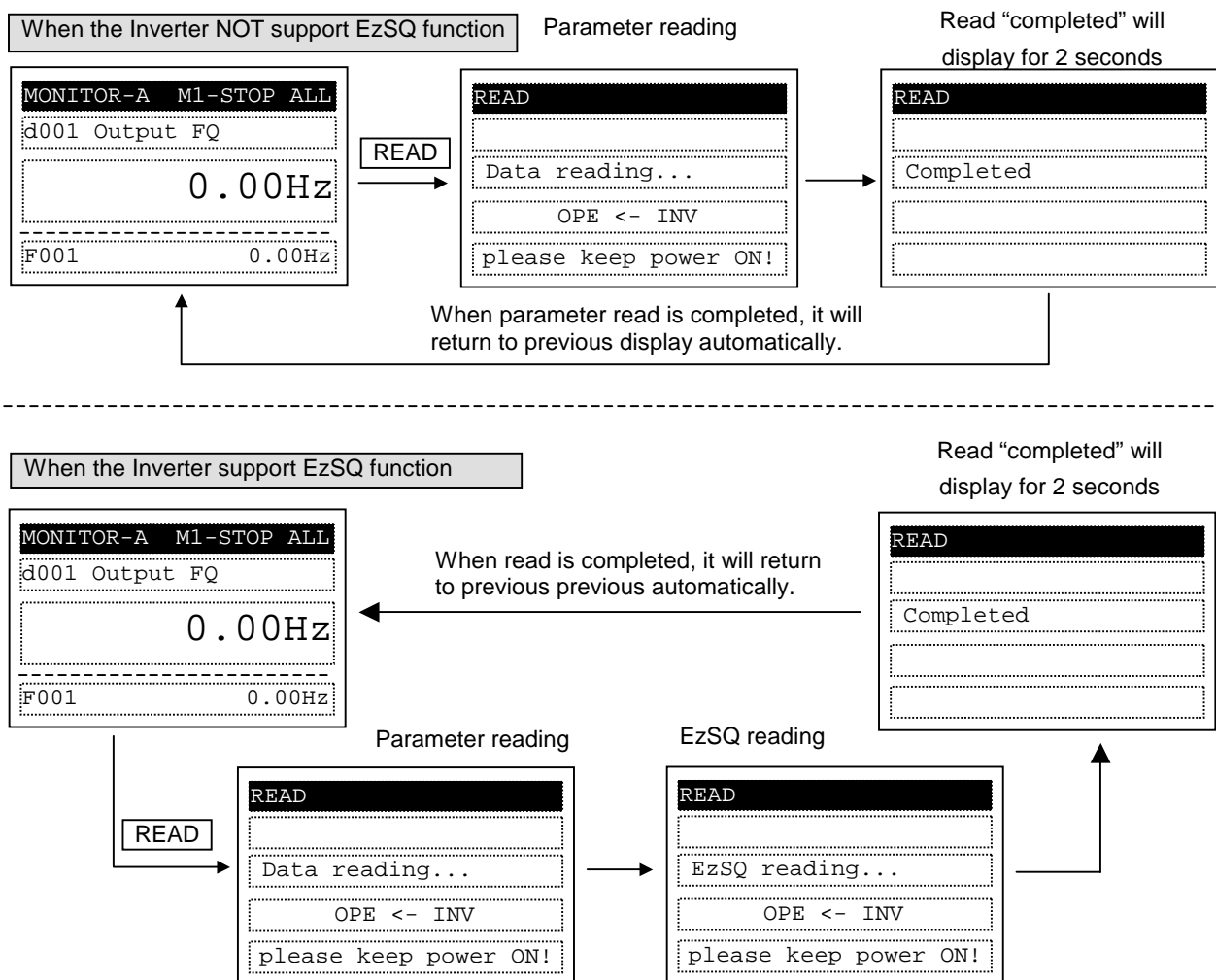

NOTE: All inverter parameters saved in WOP are overwritten after the [READ] key is pressed.

5.2 R/W Storage Mode: Single · WRITE function

After pressing the [WRITE] key in any display mode except Read mode and Option mode, the parameter settings stored in WOP are transferred to the inverter. EzSQ program is transferred to the inverter automatically after parameter copy is finished if the Inverter supports EzSQ function. It returns to previous display after write is completed.

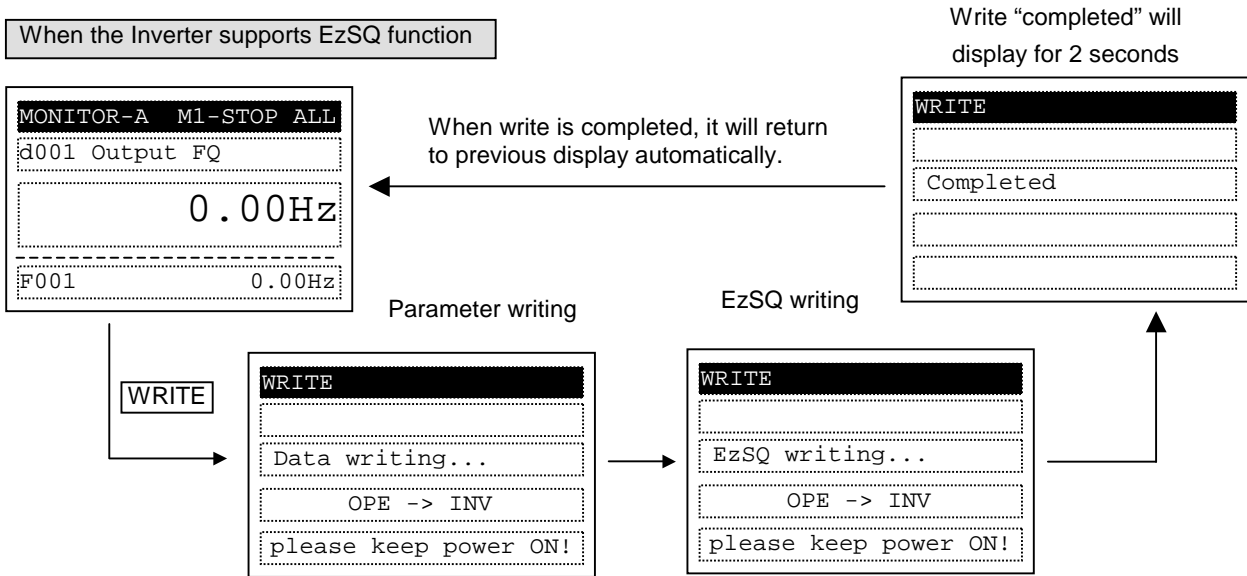
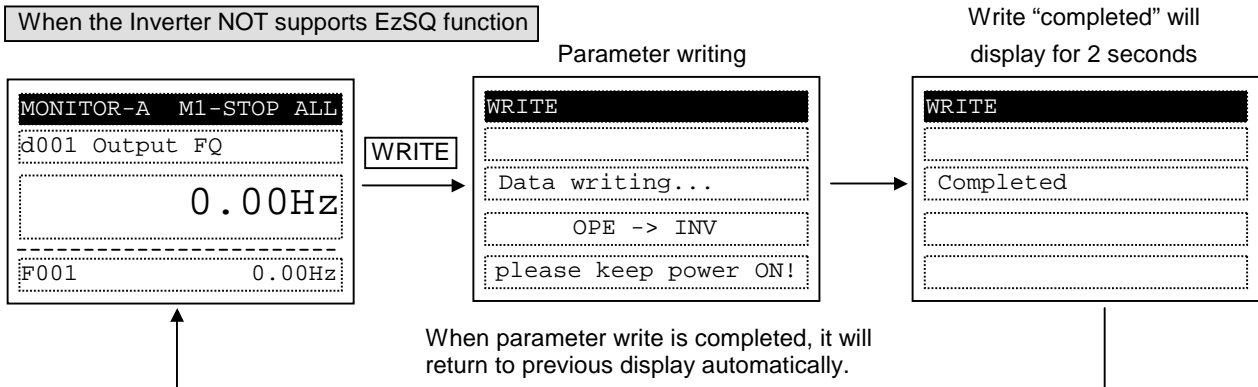

5.3 R/W Storage Mode: Quad · READ function

It is possible to handle four sets of inverter parameters or read/write EzSQ program independently when the item of "R/W storage mode" is selected to [02: Quad]. In this case, WOP can save four sets of inverter parameters or one set of inverter parameters and one EzSQ program. Please note that one EzSQ program takes up memory area of three sets of inverter parameters, which are No.2, No.3 and No.4.

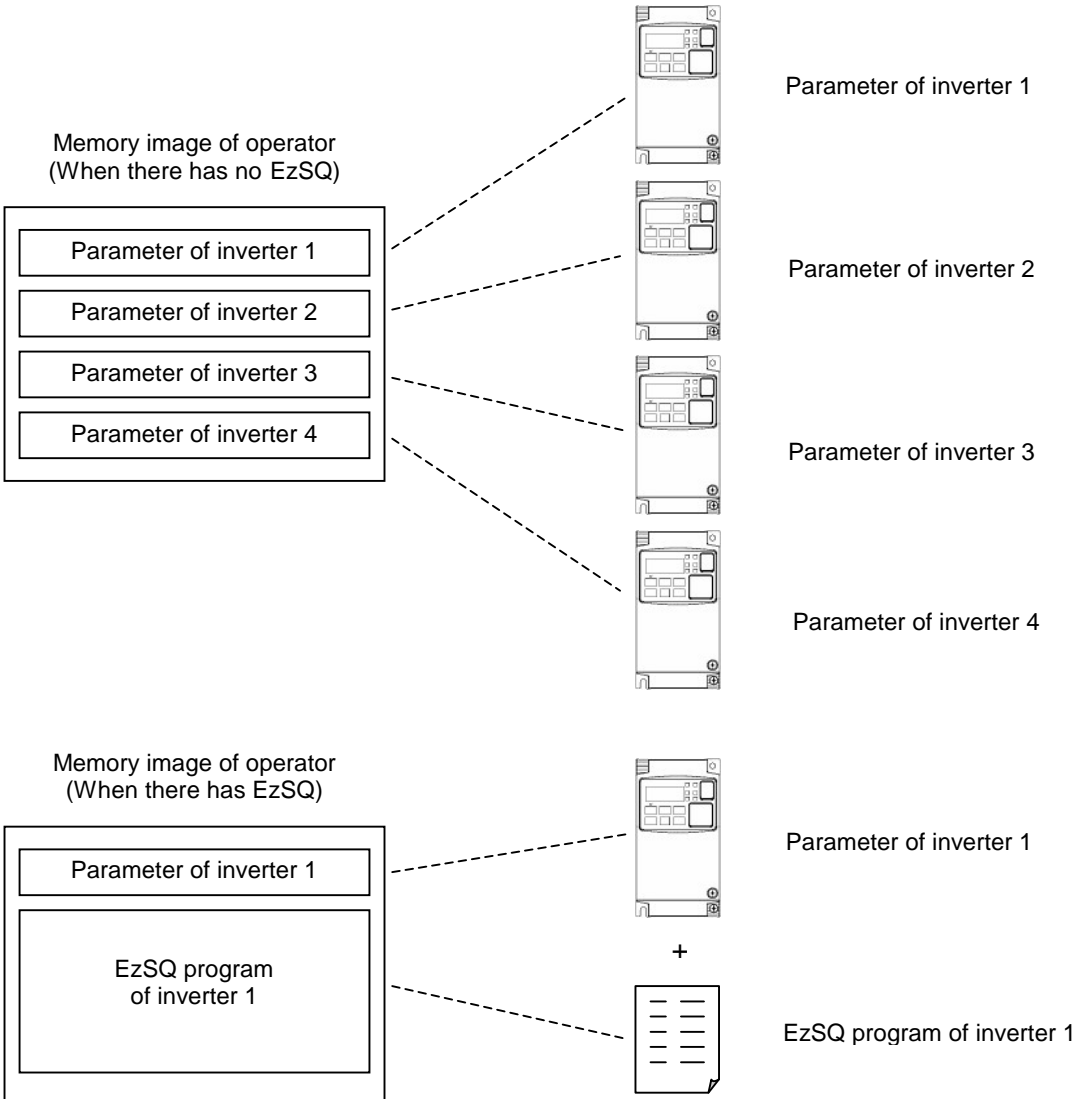

In any display mode except Write mode and Option mode, the read screen is displayed after pressing the [READ] key. If there are no parameters stored in operator, it shows "--", as described in the right figure.

Use the [△] or [▽] key to move the cursor up and down to select the memory number to be stored.

After pressing the [SET] key, 5 selection items are displayed as described follows.

- 01: Read data
- 02: Read data+EzSQ
- 03: Verify data
- 04: Verify EzSQ
- 05: Cancel

Note: only three selection items 01, 03 and 05 are displayed when memory No.2, No.3 or No.4 is selected.

A overwritten confirming screen are displayed after the [SET] key is pressed. If approving, press the [SET] key, if not, press the [ESC] key.

This will be displayed when item "02" is selected.

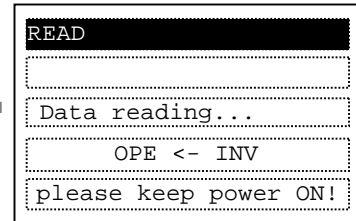
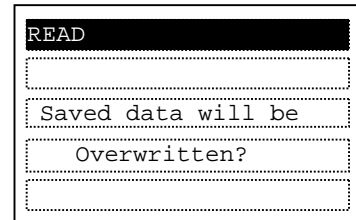
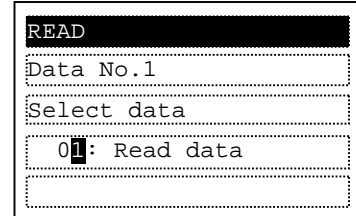
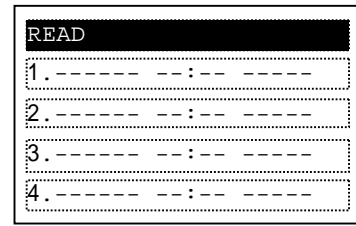
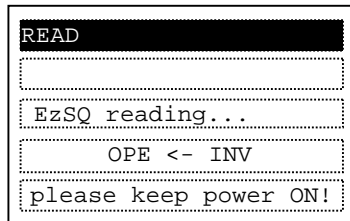

Transform automatically

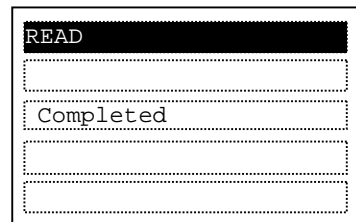

Transform automatically

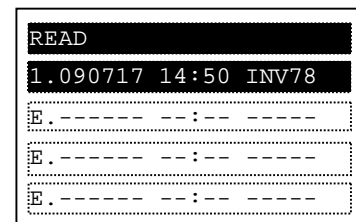

It returns to the navigation layer of read mode automatically after the read is completed, the read operation date and time, inverter type will be updated. (If EzSQ program is saved in WOP, the No.2, No.3 & No.4 will display "E" as described in the right figure.)

5.4 R/W Storage Mode: Quad · VERIFY function

In any display mode except Write mode and Option mode, the read screen is displayed after pressing the [READ] key.

Use the [△] or [▽] key to move the cursor up and down to select the data number to be verified.

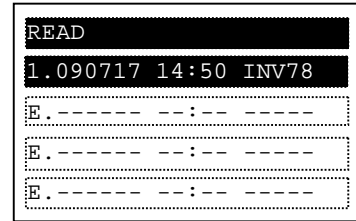

When memory number No.1 is selected, it moves to the below layer after pressing the [SET] key. There are five selections described as below, where item 03 and item 04 are selected to verify data and EzSQ.

- 01:Read data
- 02:Read data+EzSQ
- 03:Verify data
- 04:Verify EzSQ
- 05:Cancel

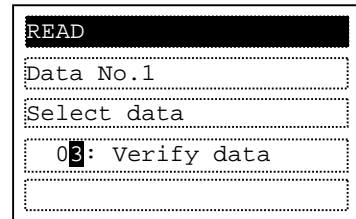

It will displayed when select "04" and the EzSQ be verified.

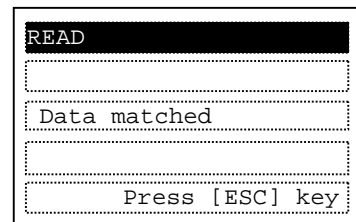
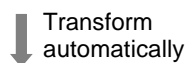
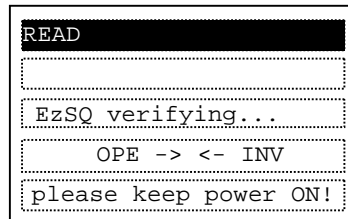
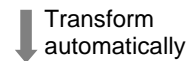
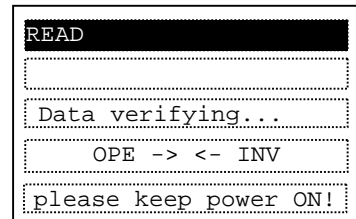

The result is shown automatically after the parameter or EzSQ verification is completed.

It returns to navigation level of Read mode after the [ESC] is pressed.

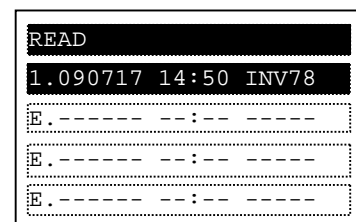

5.5 R/W Storage Mode: Quad · WRITE function

In any display mode except READ mode and Option mode, the write screen is displayed after pressing the [WRITE] key .

Use the [△] or [▽] key to move the cursor up and down to select the data number to be written.

After pressing the [SET] key, 3 selection items is displayed as described follows.

- 01: Write data
- 02: Write data+EzSQ
- 03: Cancel

Note: only two items 01 and 03 are displayed when memory No.2, No.3 or No.4 is selected.

The parameters are written after the [SET] key is pressed. The display of data is shown as described in the right figure.

It will be displayed when item "02" is selected.

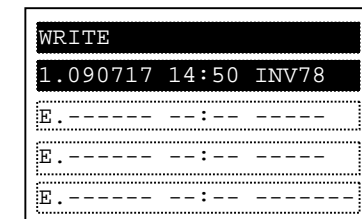
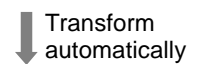
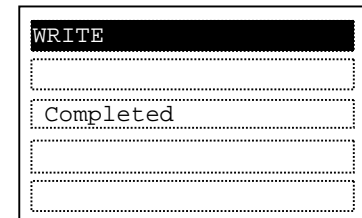
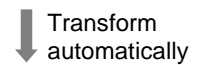
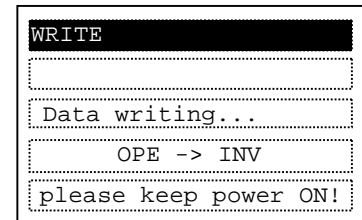
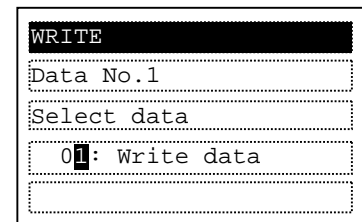
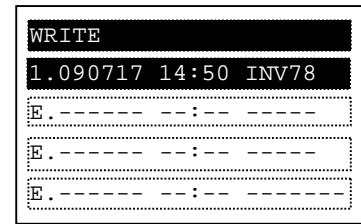
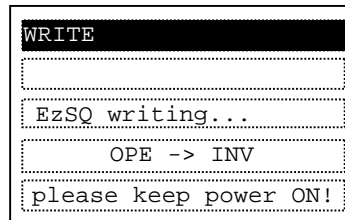

After the parameter writing is completed, it returns to navigation level of the write mode automatically.

5.6 Operation condition of read and write function

Please note that the read and write function are invalidated according to the state and the setting of inverter as shown in below table.

The operation condition of reading or verifying parameter(WOP←INV)

State and setting of inverter	Only parameter	Parameter+EzSQ
Inverter is running, EzSQ is running, written unable.	Validity	Validity
Soft locked (b031)	Validity	Validity
Display is limited (b037)	Validity	Validity
Password is being set	Validity	Invalidity
Trip happened	Validity	Validity

The operation condition of writing parameter(WOP→INV)

State and setting of inverter	Only parameter	Parameter+EzSQ
Inverter is running, EzSQ is running, written unable.	Invalidity	Invalidity
Soft locked (b031)	Invalidity	Invalidity
Display is limited (b037)	Validity	Validity
Password is being set	Validity	Invalidity
Trip happened	Invalidity	Invalidity

Chapter 6 Inverter setting concerning WOP

The example below explains parameter settings of WJ200 inverter concerning WOP.

NO.	Code	Function name	Content	Setting parameter
1	F001	Output frequency setting	You could set the frequency when the frequency instruction is done from the operator.	Start FQ ~ Max. FQ
2	A001	Frequency source	Select the frequency instruction source.	00: VR 01: Terminal 02: Operator 03: Modbus 04: Option 06: Pulse 07: EzSQ 10: Math
3	A002	Run command source	Select the run/stop command source.	01: Terminal 02: Operator 03: Modbus 04: Option
4	b031	Software lock mode selection	It is a function to prevent the change in data.	00: Lock(SFT) 01: Only FQ(SFT) 02: Lock 03: Only FQ 10: RUN chg mode
5	b037	Function code display restriction	Select the mode of the parameter displayed in the operator.	00: All 01: Utilize 02: User 03: Compare 04: Basic 05: Monitor
6	b038	Initial display selection	Select the start display.	000: The last display after the [SET] key be pressed. 001 ~ 060: Display set by d001 ~ d060 201: Display of F001 202: Monitor mode B of WOP
7	b081	Data R/W selection	Restrict the data read/write by operator.	00: Data read/write enable 01: Data read enable / write disable 02: Data read disable / write enable 03: Data read/write disable
8	b087	Stop key selection	Make the STOP key of operator enable/disable.	00: Enable 01: Disable 02: Enable when reset a trip
9	b164	Automatic return to the initial display	It will change into the display which set by initial display selection (b038) automatically when no operation to the operator within ten minutes.	00: Enable 01: Disable
10	C001 ~ C007	Intelligent Input terminal function	If it sets to 31(OPE) and the input is turned on, the frequency instruction and the run command source will set to operator compulsorily.	31: Set to operator compulsorily
			If it sets to 51(F-TM) and the input is turned on, the frequency instruction and the run command source will set to terminal compulsorily.	51: Set to terminal compulsorily
			It shows the display which set by initial display selection (b038) when it sets to 86(DISPLAY) and the input is turned on.	86: Display limitation

Chapter 7 Error message

Error messages displayed on the screen are classified into inverter errors and WOP errors. They appear on the screen as shown below.

(1) Inverter error message

ERR1 *****

For more information, please refer to
the inverter instruction manual.

Or

?ERROR *****

Note: For more details, please refer to the each inverter instruction manual

(2) WOP error message

Display	Cause	Check item	Action	Resetting Method
COM ERROR	No signal is received from the inverter within 4 sec.	Reset the inverter. Check Inverter type • Check the connector for looseness/disconnection. • Check the cable for break.	Avoid issuing the RESET signal continuously for more than 5 sec. Change to correct Inverter type Replace the cable and the connector.	Press STOP/RESET key
INV in RUN mode	• The WRITE key is pressed while the inverter is running. • Soft-lock is turned ON.	• Check if the WRITE key is pressed while the inverter is running. • Check if the WRITE key is pressed while Soft-Lock is ON.	• The WRITE key should be pressed only while the inverter stops. • Release the Soft-Lock (of the inverter).	
INV in TRIP mode	WRITE key is pressed while the inverter trips.	Check if the inverter trips.	Reset the inverter from the trip status.	
INV Type Un-match	An attempt was made to write parameter between different type inverters.		Writing is possible only between the same type inverters.	Supply the power again.
Read lock enabled	In case of display "READ LOCK".		Release the Read Lock.	
Data Check Sum Error	EEPROM of WOP is overloaded. It reaches the EEPROM's Write Limitation		If the same error appears after the power is supplied several times, the operator is defective.	
INV Check Sum Error	The parameters in WOP and the parameters written into the inverter are unmatched.		If the same error appears several times, the inverter is defective. (NOTE 1)	

NOTE 1: It happens sometimes when writing data into a different voltage class and capacity of the inverter. (Please refer to the each inverter instruction manual.)

Chapter 8 Troubleshooting

For the troubleshooting of the inverter, refer to the inverter instruction manual. In this section, the troubleshooting of the operator will be described.

(1) No data appears on the screen.

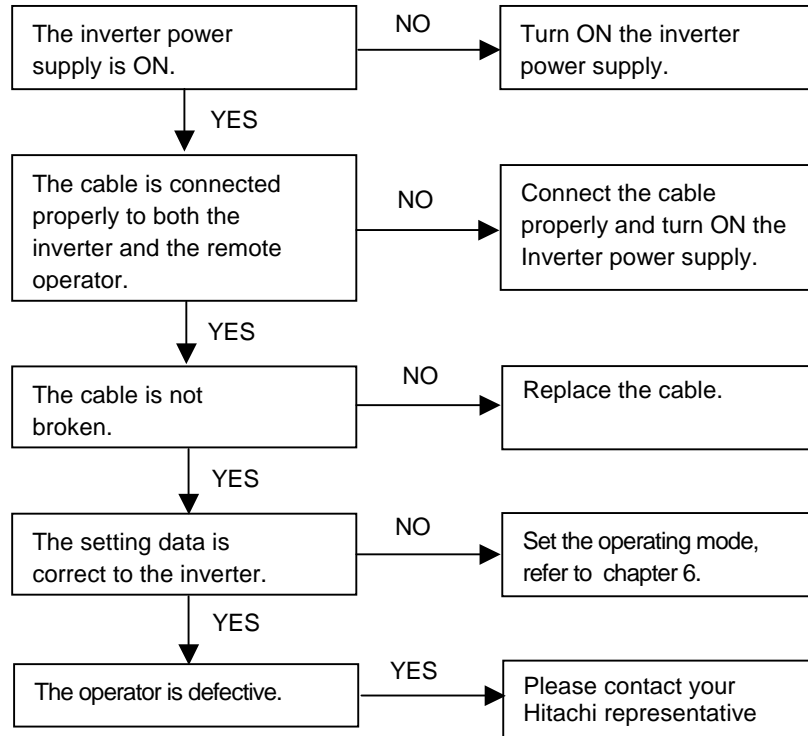

(2) Key operations are ignored.

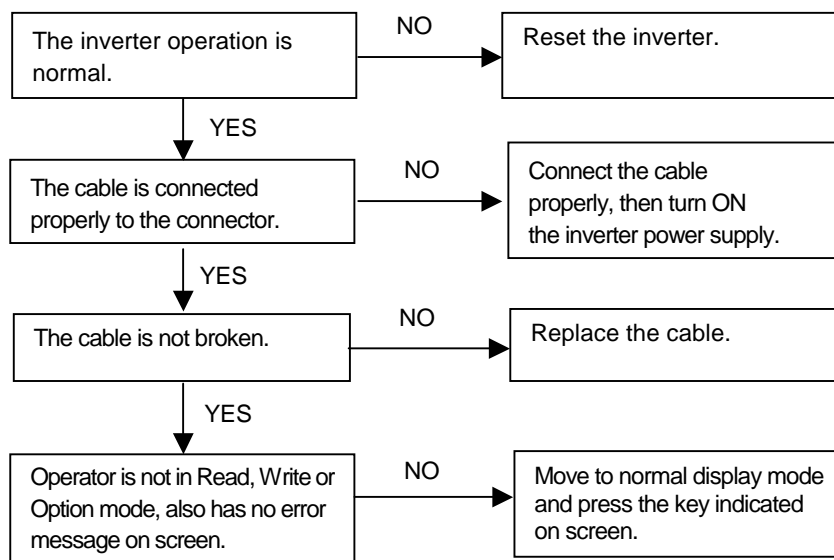

(3) If the operator screen becomes dark or characters cannot be identified, inductive noise may be entered from the cable. Separate WOP cable more than 15 cm from other cables. To reset the disturbed screen, turn ON any keys of WOP. If the same symptom appears again, turn OFF the inverter power supply or reset the terminal reset signal.

Chapter 9 Specification

Specification	Contents
Model	WOP
Display	Digital display by LCD (132×64 dot)
Language display	3 languages (English, Japanese, Chinese) Correspondence
External dimension	123(H) × 80(W) × 21 (D) mm
Weight	0.1kg
Power supply voltage	4.9 to 5.2 VDC
Ambient temperature	-10 to 50 degree C
Humidity	20 to 90% RH (no dew condensation)
Store temperature	-20 to 65 degree C
Place to use	1000m or less in height (at a place with no corrosion gas and dust).
Transmission method	RJ45 (RS-422)
Transmission rate	19.2 kbps/4800bps (Switching)
Resin color	Black (Color No.: BK2D115)
Seat color	Black
Read frequency	100,000 times
Others	Built-in real time clock Backup time (Including power OFF status time): About 4 years@25degree C Built-in battery: Coin type lithium battery CR1220

Battery exchange

There is a real time clock IC built-in whose power is supplied by a battery when outside power supply is turned off. When the battery comes to it's life, the clock IC does not renew the time when power supply of WOP is turned off.

The clock date stored in the IC will be reset to a default value January 1, 2001 when power supply of WOP is turned on. Thus, the time of Trip mode, Read mode and Write mode cannot be displayed correctly unless the time is set properly in Option mode after power supply of WOP is turned on. However, there is no special bad influence for operating except displaying proper time.

When exchanging the battery, please disassemble the case by removing four screws backside of the operator. The plus pole of the battery (flat one) must be installed upward so that the minus pole face to substrate. Please take out the old battery using a thin minus driver, and be careful not to damage PCB and any part on the PCB.

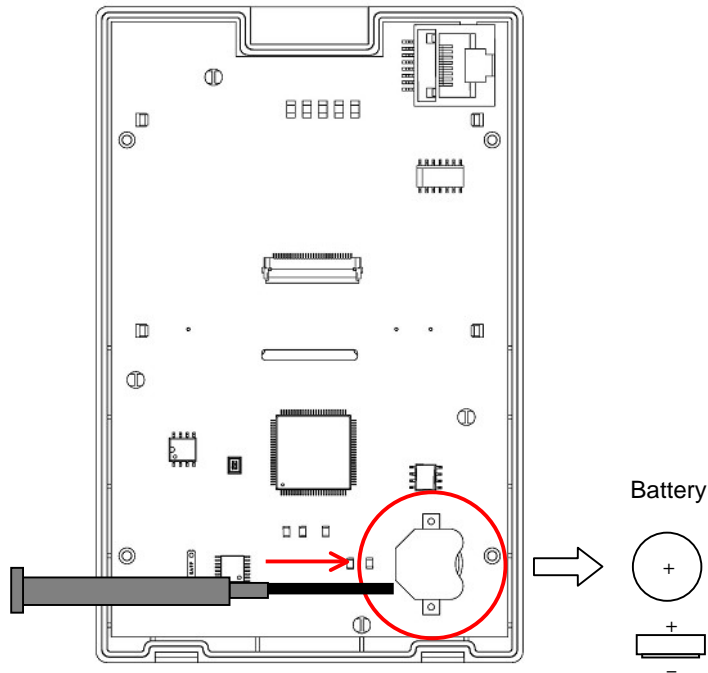

Change battery
Name : Coin type lithium battery
Recommended Type :
CR1220 (made by MAXELL)

