

iStart

Digital Soft Starter with Internal Bypass 17-1100A, 208-690V



Instruction Manual

Ver: 1.0.0.8

25/02/2016

www.solcon.com



iStart Instruction Manual

Table of Contents

1.	Safety & Warnings	6
1.1	Safety	6
1.2	Attention.....	6
1.3	Warnings.....	6
2.	Technical Data	7
2.1	Introduction	7
2.2	Rating and Frames Sizes	7
2.3	Starter Selection	8
2.3.1	Motor Current and Starting Conditions.....	8
2.3.2	Mains (Line to Line) and Control Voltage	8
2.3.3	Ordering Information.....	9
3.	Recommended Wiring Scheme.....	10
3.1	Mains and Control Description	10
3.2	Input/Output Indication	12
3.2.1	Bottom View of the Control Module.....	12
3.3	Typical Wiring Scheme – In Line Connection and internal 24V source.....	13
3.4	Typical Wiring Scheme – In Line Connection and external 24V source	14
3.5	Wiring Notes	14
3.6	Power Wiring Scheme for “Inside-Delta” Connection	15
3.7	Option Card Connections.....	16
3.7.1	Modbus Communication (Option 3M)	16
3.7.2	Profibus Communication (Option 3P).....	16
3.7.3	DeviceNet Communication (Option 3D)	17
3.7.4	Analog I/O (Option 5).....	17
3.7.5	Analog I/O (Option 6).....	17
3.7.5.1	Thermal Inputs.....	18
3.7.6	Short Circuit Protection.....	19
3.7.6.1	Recommended fuse selection procedure:	19
3.7.7	“Inside-Delta” Mode	19
3.7.7.1	General Information	19
3.7.7.2	Notes on “Inside Delta” Connection	19
4.	Dimensions	21
5.	Installation.....	31
5.1	Prior to Installation	31
5.2	Mounting	31
5.2.1	IP-54 Remote Keypad Installation.....	32
5.3	Temperature Range & Heat Dissipation	33
5.3.1	Calculating the Enclosure Size, for Non-Ventilated Metallic Enclosure	33
5.3.2	Additional Ventilation	33
5.4	Installing an Option Card.....	33
5.4.1	Preinstallation Instructions for Installing an Option Card	33
5.4.2	Opening the Control Panel.....	33
5.4.3	Removing the Connector Cover.....	34
5.4.4	Inserting the Option Card and Closing the Unit.....	35
5.5	Setting the Thermistor In and Analog Out Option Card (Option 5).....	36
5.6	Setting the Analog Option – 3XRTD Thermal Sensor Option Card (Option 6)	37
5.6.1	PT100 [C°/Ω] Table	37
6.	Control Keypad.....	39
6.1	LCD Arrangement.....	39
6.2	Push-Buttons	40

6.3	Status LEDs.....	40
6.4	Reviewing Parameters.....	40
6.4.1	Modifying the Parameter.....	40
6.5	Special Actions Performed in TEST/MAINTENANCE Mode.....	41
6.5.1	View Firmware Version/Version Date/Version CRC16.....	41
6.5.2	Reset to Factory Default Parameters.....	41
6.5.3	Reset Statistical Data.....	42
6.6	Overview of All Mode Pages and Factory Defaults.....	43
6.6.1	Main Parameters – page 1.....	47
6.6.1.1	Tripping Curves of the Integrated Overcurrent Protection.....	50
6.6.1.2	Tripping Curves of the Integrated Overload Protection.....	56
6.6.2	Start/Stop adjust – page 2 of Basic (pages 2-3 of Professional, pages 2-5 of Expert).....	58
6.6.2.1	Soft Start Parameters.....	62
6.6.2.2	Soft Stop Parameters.....	63
6.6.3	Special Features – page 6 of Professional and Expert Only.....	64
6.6.3.1	Extend Setting.....	65
6.6.3.2	2 Phase Operation.....	66
6.6.4	Fault Parameters – Page 3 of Basic (page 5 of Professional and page 7 of Expert).....	67
6.6.5	Autoreset Params – Page 4 of Basic (page 6 of Professional and page 8 Expert).....	73
6.6.6	I/O Programming Parameters – Page 5 of Basic (7 of Professional and 9 of Expert).....	75
6.6.7	Option Setting Parameters – Page 10 of Professional and page 12 of Expert.....	78
6.6.7.1	Option Setting Parameters for the Modbus Communication Card.....	78
6.6.7.2	Option Setting Parameters for the Profibus Communication Card.....	78
6.6.7.3	Option Setting Parameters for the Device Net Communication Card.....	79
6.6.7.4	Option Setting Parameters for the Thermistor Voltage Analog Card.....	79
6.6.7.5	Option Setting Parameters for the Temp. Relay 3In Analog Card.....	80
6.6.8	Global Parameter.....	80
6.6.9	Statistical Data – page 11.....	80
6.7	Event Logger – page 8 for Basic (page 11 for Professional, page 12 for Expert).....	82
6.7.1	Event Summary.....	82
6.7.2	Event Details.....	83
6.8	Actual Data View.....	84
6.8.1	Default Data View.....	85
7.	Starting Procedure.....	85
7.1	Standard Starting Procedure.....	86
7.2	Examples of Starting Curves.....	88
7.2.1	Light Load-Pumps, Fans, Etc.....	88
7.2.2	High Inertia Loads – Fans, Centrifuges, Etc.....	88
7.2.3	Choosing a Suitable Pump Curve (Centrifugal Pumps).....	89
7.2.3.1	Starting Curve.....	89
7.2.3.2	Stopping Curve.....	89
7.2.3.3	Final Torque During Soft-Stopping a Pump Motor.....	91
8.	Communication.....	92
8.1	Modbus Communication.....	92
8.1.1	Features.....	92
8.1.2	Basic Structure of the Serial Link Frame.....	92
8.1.2.1	Sync (Silent Interval).....	92
8.1.2.2	Serial Link No. (Slave Address).....	93
8.1.2.3	Function.....	93
8.1.3	List of Functions Supported by the iStart.....	93
8.1.3.1	Data.....	93
8.1.3.2	CRC.....	93
8.1.3.3	iStart Memory Organization.....	93
8.2	Actual Data (Read Word Registers).....	93
8.2.1	Example 1: Read Actual Data.....	96
8.3	Setting Parameters (Read\Write Word Registers).....	96
8.3.1	Main Parameters.....	96
8.3.2	Start Parameters (First Adjust).....	99

8.3.3	Stop Parameters (First Adjust).....	100
8.3.4	Special Features Parameters	100
8.3.5	Fault Parameters	101
8.3.5.1	Faults List	102
8.3.6	Auto Reset Parameters	103
8.3.7	I/O Programming Parameters	103
8.3.8	Global Parameters.....	107
8.3.9	Communication Parameters	108
8.3.10	Example 2: Read Setting Parameters.....	108
8.3.11	Example 3: Write a Single Setting Parameter	110
8.3.12	Example 4: Write Multiple Setting Parameters	111
8.4	Control Register Write (Write Word Register).....	111
8.4.1	Example 5 - Control Register Write.....	113
8.5	Diagnostics	113
8.6	Exception Responses	114
8.6.1	Exception Code Response Frame	114
8.6.2	Exception Codes Supported by the iStart	114
8.6.3	Example 6: Exception Response	115
8.7	Profibus Communication	116
8.7.1	Global Parameters.....	116
8.7.2	Operation Mode in Profibus	116
8.7.3	Description of the DPV0 (Cyclic) Frame.....	117
8.7.3.1	Structure of the iStart Reception Frame.....	118
8.7.3.2	Structure of the iStart Transmission Frame.....	118
8.7.3.3	Choosing the Reception DPV0 Registers.....	118
8.7.3.3.1	Using GSD to Select the Registers to Display in DPV0	118
8.7.3.3.2	Using a Data Request (DPV1) to Select the Registers to Display in DPV0.....	119
8.7.4	Operations that are Available in DPV1.....	120
8.7.4.1	Read and Write from Random Registers by Data Request	120
8.7.4.1.1	Sample Data Request to Read Registers 2 Through 6	121
8.7.5	Configure PROFIBUS in the iStart.....	122
8.7.6	Watch Dog Definition	122
8.7.7	Actual Data Register Numbers (Decimal)	123
8.7.8	Default Order of Register Numbers.....	125
8.7.9	Setting Parameters for Data Request	127
8.7.9.1	Main Parameters	127
8.7.9.2	Start Parameters.....	127
8.7.9.3	Stop Parameters.....	127
8.7.9.4	Dual Adjust Parameters	127
8.7.9.5	Energy Save & Speed Parameters	128
8.7.9.6	Fault Parameters	128
8.7.9.7	I/O Programming	128
9.	Installing a Fan on Size A, B and C	129
10.	Troubleshooting	130
10.1	Blank RMA Form.....	133
11.	Technical Specifications	134

Table of Figures

Figure 1: Bottom view of the control module.....	12
Figure 2: Analog I/O (option 5)	17
Figure 3: Analog I/O (option 6)	18
Figure 4: Dimensions for installing the remote keypad	32
Figure 5: Removing the connector cover	34
Figure 6: Location of the header connectors J1 and J6	35
Figure 7: Inserting an option card - overview	35
Figure 8: Location of the dip switches on the Thermistor In and Analog Out option card	36
<i>Figure 9: iStart Control Keypad</i>	<i>39</i>
Figure 10: U.S. Class OVERCURRENT curves – U1 curves.....	50
Figure 11: U.S. Class OVERCURRENT curves – U2 curves.....	51
Figure 12: U.S. Class OVERCURRENT curves – U3 curves.....	51
Figure 13: U.S. Class OVERCURRENT curves – U4 curves.....	52
Figure 14: U.S. Class OVERCURRENT curves – U5 curves.....	52
Figure 15: IEC Class OVERCURRENT curves – C1 curves.....	53
Figure 16: IEC Class OVERCURRENT curves – C2 curves.....	53
Figure 17: IEC Class OVERCURRENT curves – C3 curves.....	54
Figure 18: IEC Class OVERCURRENT curves – C4 curves.....	54
Figure 19: IEC Class OVERCURRENT curves – C5 curves.....	55
Figure 20: Current limit.....	60
Figure 21: Accelerate time.....	60
Figure 22: Decelerate time	61
Figure 23: Stop final torque	61
Figure 24: Start curves 2-4	62
Figure 25: Start curve 5 (torque).....	62
Figure 26: Stop curves	63
Figure 27: Curve 5 – Torque curve.....	63
Figure 28: Starting curves (light load-pumps, fans, etc.)	88
Figure 29: Starting curves (high inertia loads)	88
Figure 30: Starting curve	89
Figure 31: Stopping curve	89
Figure 32: Final torque during soft-stopping a pump motor.....	91
Figure 33: DPV0 parameters (Cyclic parameters)	117
Figure 34: Updating the register number that will display at DPV0 (by Data Request).....	120
Figure 35: Reading the register number that shown in the DPV0 (cyclic) list	120
Figure 36: Choosing register number 80 hex.....	121
Figure 37: Reading 4 following register by Data Request (DPV1).....	122
Figure 38: Installing a fan (sizes A, B and C).....	129
Figure 39: Fan power connection	129

1. SAFETY & WARNINGS

1.1 Safety

	1	Read this manual carefully before operating the equipment and follow its instructions.
	2	Installation, operation and maintenance should be in strict accordance with this manual, national codes and good practice.
	3	Installation or operation not performed in strict accordance with these instructions will void manufacturer's warranty.
	4	Disconnect all power inputs before servicing the soft-starter and/or the motor.
	5	After installation, check and verify that no parts (bolts, washers, etc) have fallen into the starter.
	6	During shipping, the soft-starter might have been roughly handled, therefore, it is recommended to initialize the soft-starter by connecting supply voltage prior to operating the soft-starter with a motor.

1.2 Attention

	1	This product was designed for compliance with IEC 60947-4-2 for class A equipment.
	2	All of the iStart models are designed to meet UL and cUL requirements.
	3	Use of the product in domestic environments may cause radio interference, in which case, the user may be required to employ additional mitigation methods.
	4	Utilization category is AC-53a or AC-53b, Form 1. For further information, see Technical Specification.

1.3 Warnings

	1	Internal components and PCBs are at mains potential when the iStart is connected to mains. This voltage is extremely dangerous and will cause death or severe injury if contacted.
	2	When iStart is connected to mains, even if control voltage is disconnected and motor is stopped, full voltage may appear on starter's output and motor's terminals.
	3	The starter must be grounded to ensure correct operation, safety and to prevent damage.
	4	Check that Power Factor capacitors and overvoltage devices are not connected to the output side of the soft starter.
	5	Do not interchange line and load connections.
	6	Expert mode allows settings that can damage the starter and the motor.

The company reserves the right to make any improvements or modifications to its products without prior notice.

2. TECHNICAL DATA

2.1 Introduction

The iStart is a highly sophisticated and reliable three -phase starter. It can operate both three phase and two-phase mode. iStart is designed for simple maintenance and maximum flexibility in the field.

- You can connect motors with different mains voltages to iStart:

Frame size A, B and C: 208V to 600V

Frame size D to I: 208V to 600V

208V to 690V

- Communication cards are easy to connect and replace.
- Includes an internal bypass.
- You can connect an external display so that you can install iStart inside a cabinet and still monitor and program it without opening the cabinet.
- iStart's Ground Fault protection checks that the total current always remains zero. If a ground fault occurs, iStart trips.
- Includes built-in Motor Unbalance protection.
- Optional fan that can added later allows you to increase the number of starts per hour.
- Includes an event logger for start, stop, bypass open and close, and other events. Each log entry includes: time, date, voltage, current and trip state.

2.2 Rating and Frames Sizes

Frame Size	FLC (A)	Dimensions WxHxD (mm)	Dimensions W/Fan WxHxD (mm)	Weight
A	17	122x245x147	127x251x188	3.175 Kg (for fan: +1.33 Kg)
A	31			
A	44			
B	58	132x275x208	132x276x249	5.23 Kg (for fan: +1.38 Kg)
B	72			
B	85			
C	105	175x388x234	175x388x275	10.89 (for fan: +1.925 Kg)
C	145			
C	170			
D	230	375x644x275		37 Kg
D	310			
D	350			
E	430	375x644x285		38 Kg
F	515	480x691x300		47 Kg
G	590	480x791x300		56 Kg
G	690			
H	720	510x791x305		60 Kg
H	850			
I	960	559x815x316		85 Kg
I	1100			

2.3 Starter Selection

Use the following criteria to select the starter:

2.3.1 Motor Current and Starting Conditions

Select the starter according to motor's Full Load Ampere (FLA) that is indicated on its nameplate (even if the motor will not be fully loaded).

The iStart is designed to operate under the following maximum conditions:

Ambient Temperature [°C]	Starting Current [A]	Acceleration Time [sec]
40	350% X In	20

Max. Starts per Hour: four (4) starts per hour.

Note:

For very frequent starts (inching applications) the inching current should be considered as the Full Load Current (FLC) (consult factory).

2.3.2 Mains (Line to Line) and Control Voltage

Frame Size	Mains (Line to Line) Voltage	Control Voltage	Fan Voltage ¹
A to C	208V to 480V, 50/60Hz, +10% -15% or 208V to 600V, 50/60Hz, +10% -15%	95-230VAC/DC, 50/60Hz, +10% -15%	Fan is optional 115VAC, 50/60Hz, +10% -15% or 230VAC, 50/60Hz, +10% -15%
D to I	208V to 480V, 50/60Hz, +10% -15% or 208V to 600V, 50/60Hz, +10% -15% or 208V to 690V, 50/60Hz, +10% -15%	115VAC, 50/60Hz, +10% -15% or 230VAC, 50/60Hz, +10% -15%	Fan is included 115VAC, 50/60Hz, +10% -15% or 230VAC, 50/60Hz, +10% -15%

¹ Fan is included for frame sizes D and above. It is optional for frame sizes A-C and can be ordered as an option separately.

2.3.3 Ordering Information

iStart	58-	400-	230-	24-	0-	S
	Full load Current	Mains Voltage	Control Voltage	Control Input Voltage	Options	Front Panel
Full load Current						
Specify	Description					
Starter's FLC [A]	17, 31, 44 (Size A) 58, 72, 85 (Size B) 105, 145, 170 (Size C) 230, 310, 350 (Size D) 430 (Size E) 515 (Size F) 590, 690 (Size G) 720, 850 (Size H) 960, 1100 (Size I)					
Mains Voltage						
Specify	Description					
480	208 – 480 VAC, 50/60Hz , +10% -15%					
600	208 – 600 VAC, 50/60Hz , +10% -15%					
690	208 – 690 VAC, 50/60Hz , +10% -15%. Only available with 230A and above.					
Control Voltage (Terminal A1, A2)						
Specify	Description					
95-230	95-230 VAC, 50/60Hz , +10% -15% or 95-230 VDC ⁽⁶⁾					
115	115 VAC, 50/60Hz , +10% -15% ⁽⁷⁾					
230	230 VAC, 50/60Hz , +10% -15% ⁽⁷⁾					
Note:	Control voltage cannot be modified on site.					
Control Input Voltage (Terminals 1-5)						
Specify	Description					
24	24 VDC/VAC +10% -15%. (in this option the iStart also supplies 24VDC)					
Note:	Control input voltage cannot be modified on site.					
Options						
Specify	Description					
0	No options					
2P	2 phase control ⁽⁵⁾					
3M	Communication RS-485 Board (MODBUS) ⁽¹⁾⁽³⁾					
3P	Communication Profibus ⁽¹⁾⁽³⁾ (D type connector)					
3D	Communication Device Net ⁽¹⁾⁽³⁾ (terminal connectors)					
5	Analog card – Thermistor in and Analog out ⁽²⁾⁽³⁾					
6	3XRTD Thermal sensors ⁽²⁾⁽³⁾					
8	Harsh environment treatment					
D	Remote Keypad ⁽³⁾					
F115	Fan unit ⁽⁴⁾ 115VAC fan unit (for 17A to 170A)					
F230	Fan unit ⁽⁴⁾ 230VAC fan unit (for 17A to 170A)					
ROC	Chinese language LCD					
RU	Russian language LCD					
Notes:	⁽¹⁾ Only one option from 3M, 3P, 3D. ⁽²⁾ Only one option from: 5, 6. ⁽³⁾ You can install these options on site. ⁽⁴⁾ You can install these options on site for frame sizes A, B and C only. ⁽⁵⁾ Factory installed option. ⁽⁶⁾ Only for sizes A, B and C. ⁽⁷⁾ Only for sizes D and E.					
Front Panel						
Specify	Description					
S	Standard					

3. RECOMMENDED WIRING SCHEME

3.1 Mains and Control Description

Refer to drawing on page 12

Indication	Description	Remarks
1L1, 3L2, 5L3	Connection to mains voltage up to 690V	
2T1, 4T2, 6T3	Connection to motor	
G	Connection to ground	For proper operation and for safety reasons soft iStart must be properly grounded.
Terminal A1	Control phase	95-230VAC\DC +10% -15%
Terminal A2	Control neutral (return)	
Terminal 12 (NC) Terminal 11 (C) Terminal 14 (NC)	Programmable auxiliary output relay 1	<p>Voltage free, 8A, 250VAC, 1800VA max. The contact incorporates 0-60 seconds On & Off delays. The auxiliary output relay can be programmed to operate in the following modes:</p> <ul style="list-style-type: none"> • INACTIVE • RUN IMMEDIATE Active when there is start action. • STARTING Active during the start ramp. It stops when the bypass closes. • END OF ACC Not active during the start ramp. Active when the bypass closes. • STOP • SOFT STOP Active during ramp down. • STOP IMMEDIATE Active from ramp down and continues to be active while stopped. • ALTERNATIVE ADJUST Active when motors 2, 3, or 4 receive a command. • FAULT Active while in a fault state. • WARNING Active while in a warning state.
Terminal 22 (NC) Terminal 21 (C) Terminal 24 (NC)	Programmable auxiliary output relay 2	Same as terminals 12, 11, and 14 for relay 2.

Indication	Description	Remarks
Terminal 1,2,3	24V Input – START command	<p>The terminals can be programmed to operate in the following modes:</p> <ul style="list-style-type: none"> • INACTIVE • START • STOP • EXTERNAL TRIP • RESET • START=1,STOP=0 Apply start command when active, Or stop command when inactive. • START=1,S.STOP=0 Apply start command when active, Or soft stop command when inactive. • 1ST ADJUST START Start command to the 1st motor. • 2ND ADJUST START Start command to the 2nd motor. • 3RD ADJUST START Start command to the 3rd motor. • 4TH ADJUST START Start command to the 4th motor. • 1ST ADJUST S.STOP Soft Stop command to the 1st motor. • 2ND ADJUST S.STOP Soft Stop command to the 2nd motor. • 3RD ADJUST S.STOP Soft Stop command to the 3rd motor. • 4TH ADJUST S.STOP Soft Stop command to the 4th motor. • MOTOR ADJUST BIT0 See 6.6.6 for more information. • MOTOR ADJUST BIT1 See 6.6.6 for more information.
Terminal 4	+24V Output	Use this terminal when the power is supplied from the internal power supply. Refer to section 3.3 on page 13.
Terminal 5	24V Common	Use this terminal when the power is supplied from an external power supply. The common (-) of the power supply connects to this terminal, and the +24V connects to the control inputs.
F1, F2	Power to Fan	For sizes A, B and C, connect 220V 50 Hz (for option F230 fan unit) or 115V 60 Hz (for option F115 fan unit)

3.2 Input/Output Indication

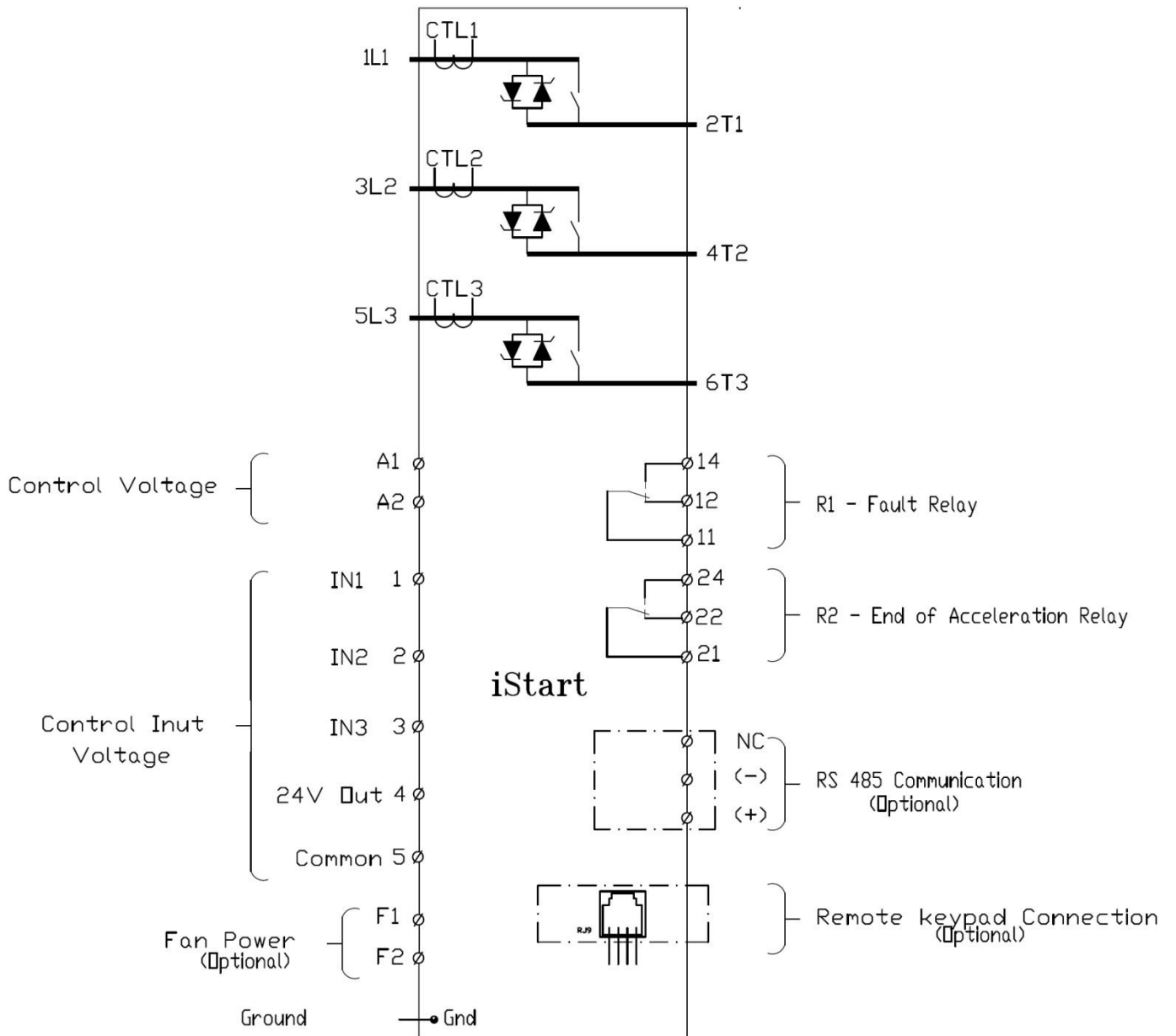

3.2.1 Bottom View of the Control Module

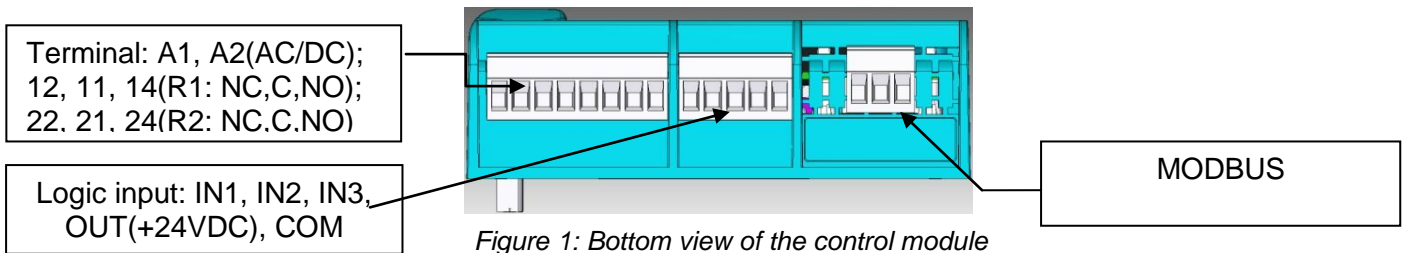

3.3 Typical Wiring Scheme – In Line Connection and internal 24V source

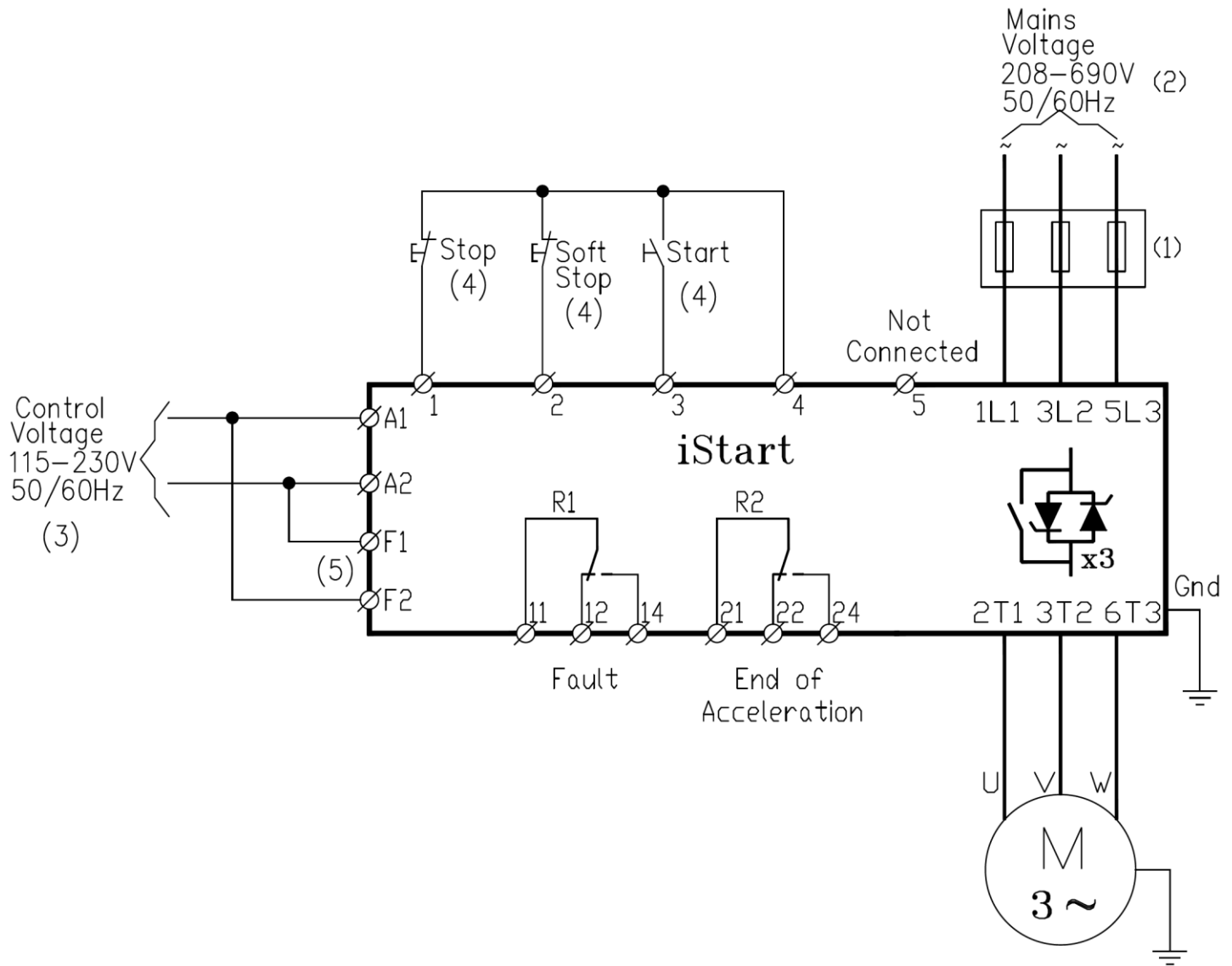

Notes:

- (1) – Use fuses for type 2 coordination. Refer to section 3.7.6 on page 19
- (2) – Mains voltage of 208-600V available to all models. Mains voltage 208-690V available to 210-1100A.
- (3) – Refer to ordering information for available control voltages.
- (4) – Control inputs are shown in their default setting.
- (5) – Applicable only when optional fans are installed in frame sizes A-C.

3.4 Typical Wiring Scheme – In Line Connection and external 24V source

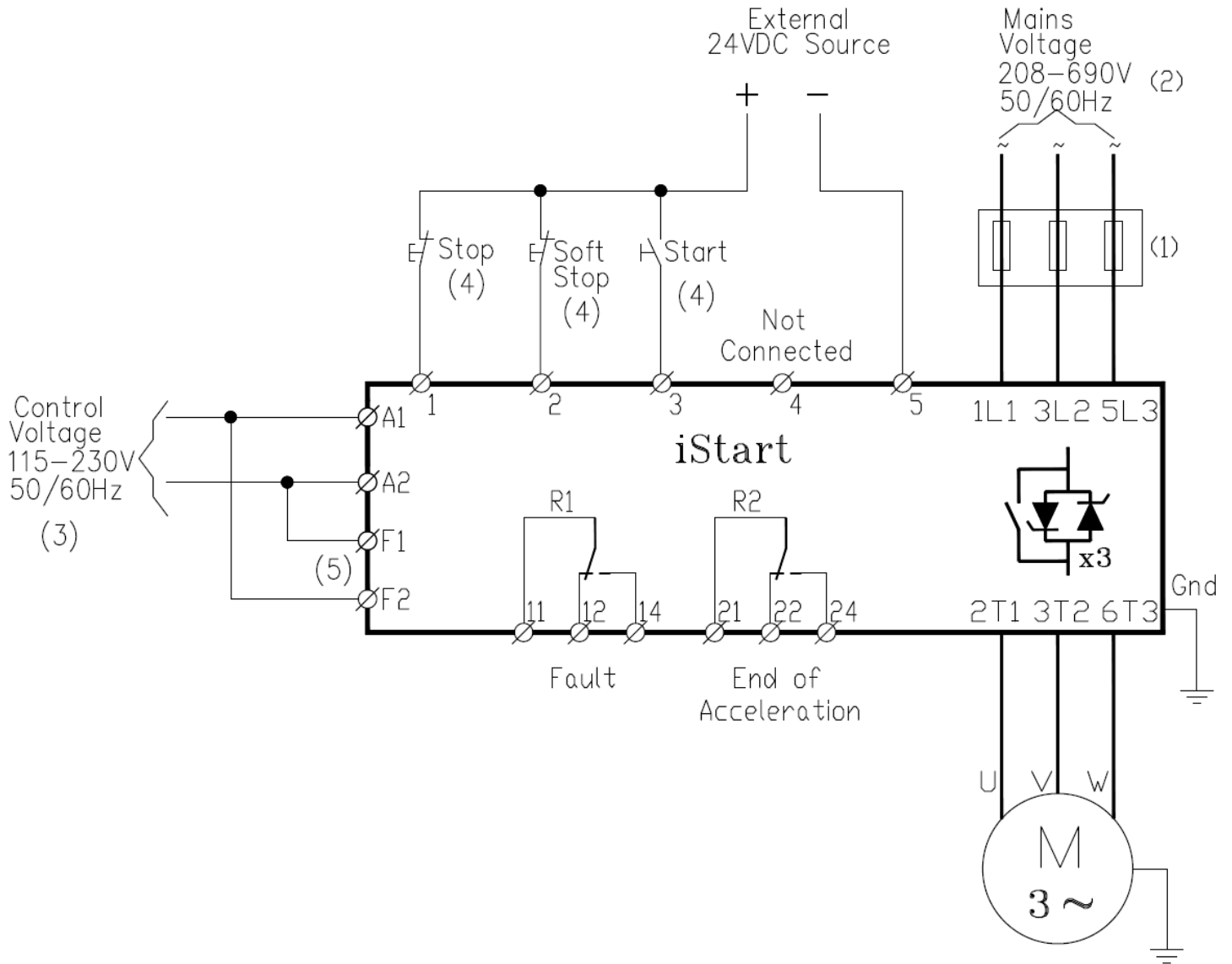

Notes:

- (1) – Use fuses for type 2 coordination. Refer to section 3.7.6 on page 19
- (2) – Mains voltage of 208-600V available to all models. Mains voltage 208-690V available to 210-1100A.
- (3) – Refer to ordering information for available control voltages.
- (4) – Control inputs are shown in their default setting.
- (5) – Applicable only when optional fans are installed in frame sizes A-C.

3.5 Wiring Notes

WARNINGS!	When mains voltage is connected to the iStart, even if control voltage is disconnected, full voltage may appear on the starter load terminals. Therefore, for isolation purposes, it is necessary to connect an isolating device upstream of the starter.
	Power factor correction capacitors and overvoltage devices must not be installed on starters load side. When required, install capacitors or overvoltage devices on starter's line side.
	iStart is not balanced while in two-phase mode. Therefore, you cannot use a motor unbalance protection because it will always cause a trip.

3.6 Power Wiring Scheme for “Inside-Delta” Connection

(IMPORTANT! - Refer to section 3.7.7 on page 19.)

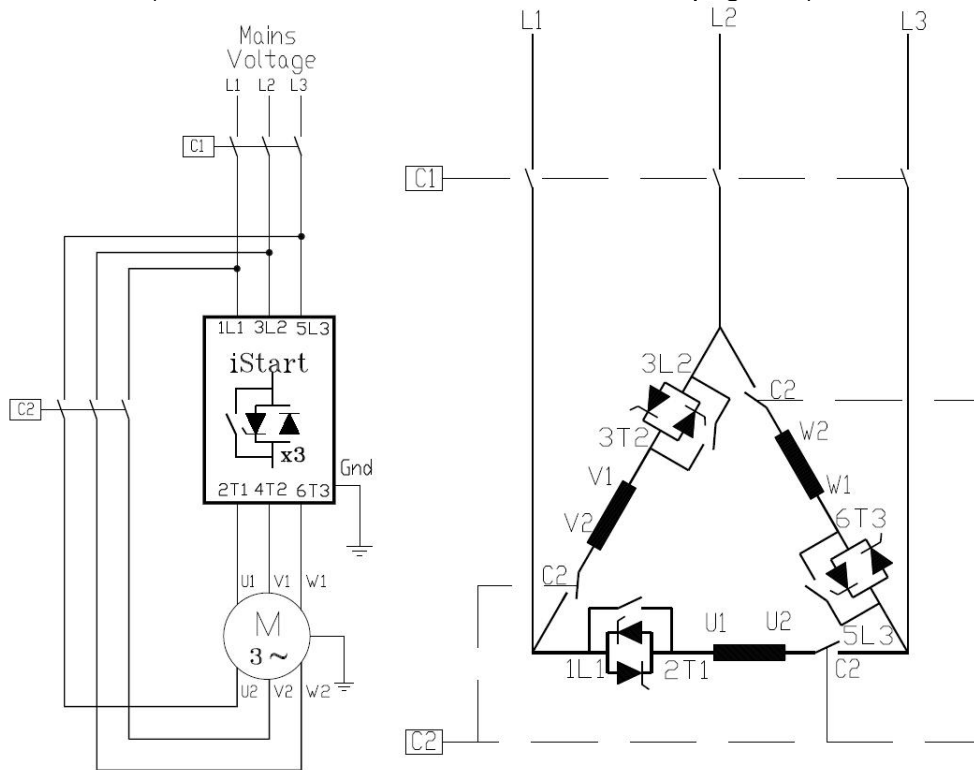

Connecting iStart INSIDE DELTA

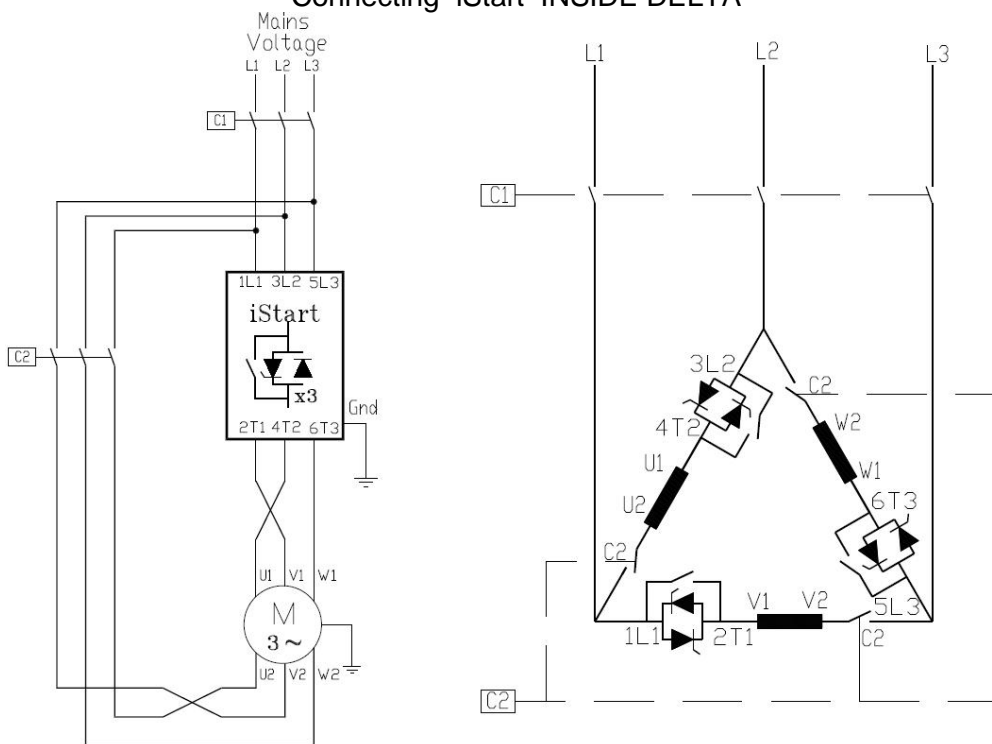

Reverse speed with iStart connected INSIDE DELTA.

WARNINGS!

Wrong connection of the iStart or the motor may seriously damage the motor

When using INSIDE DELTA it is highly recommended to use a line contactor (C1) or contactor (C2) in order to avoid possible damage to the motor if an SCR is short circuited in the iStart

Even when the inside delta contactor (C2) is open, motor terminals are “live” (full voltage) even when the contactor is open

3.7 Option Card Connections

3.7.1 Modbus Communication (Option 3M)

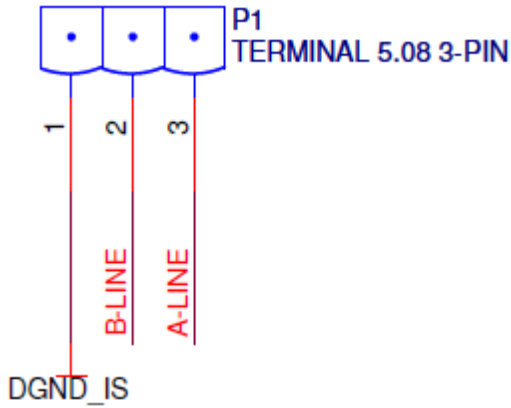
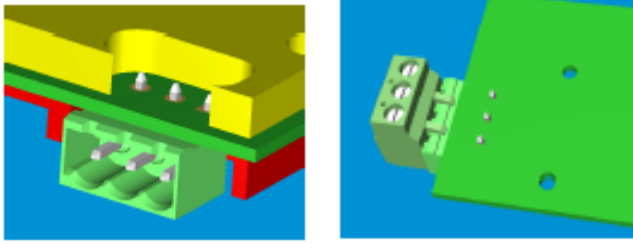

The connection are:

P1.1 – **leave not connected.**

P1.2 – Connect to **A(-)** (Crossed connection).

P1.3 – Connect to **B(+)** (Crossed connection).

Note: connect termination resistor (100Ω - 120Ω) between P1.2 and P1.3.

3.7.2 Profibus Communication (Option 3P)

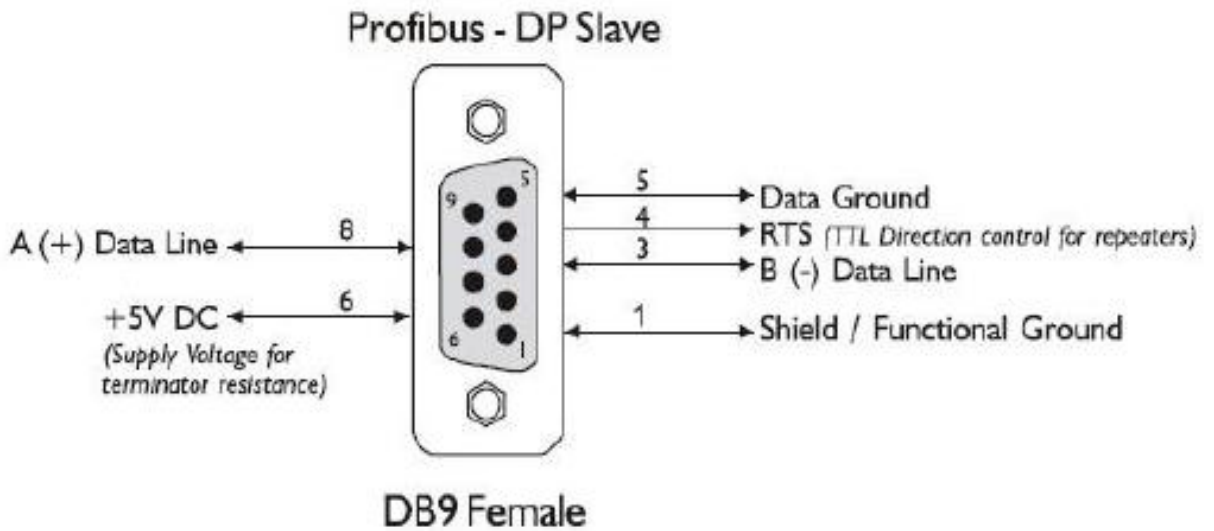

3.7.3 DeviceNet Communication (Option 3D)

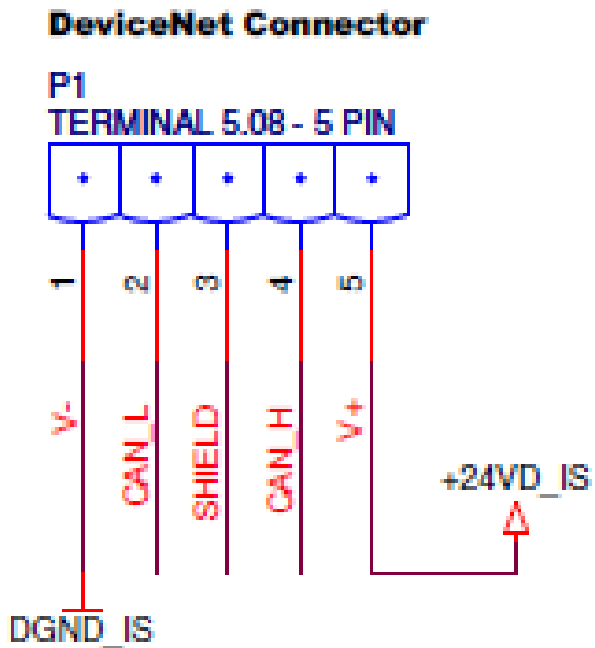

3.7.4 Analog I/O (Option 5)

- Connect the Thermistor Input between P1.4 and P1.5.
- Connect Analog Output between P1.1 (High) and P1.2 (Low).
- Leave P1.3 disconnected.
- Connect the shielded wire to P1.3.

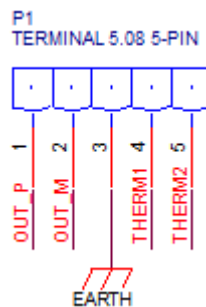

Figure 2: Analog I/O (option 5)

3.7.5 Analog I/O (Option 6)

Each analog input port is separate and defined independently.

- For connector P1:
Connect the PT100 resistor between P1.1 and P1.2.
Connect P1.2 and P1.3 without any resistance (short-circuit).
- For connector P2:
Connect the PT100 resistor between P2.1 and P2.2.
Connect P2.2 and P2.3 without any resistance (short-circuit).
- For connector P3:
Connect the PT100 resistor between P3.1 and P3.2.
Connect P3.2 and P3.3 without any resistance (short-circuit).

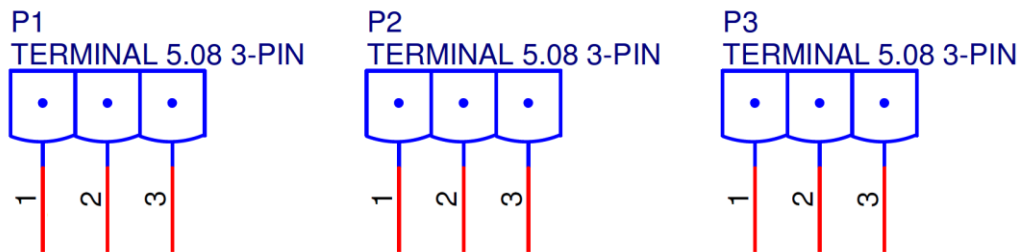

Figure 3: Analog I/O (option 6)

3.7.5.1 Thermal Inputs

The iStart can accept inputs from the RTD - Platinum 100 Ohm (Pt100) type of thermal sensors. This is a three-wire measurement system that is used to compensate for cable resistance.

Notes:

1. AWG#18 wires **must** be used. Do not exceed the maximum length of 100m.
2. Shielded cables must be used. Connect shield to external ground.
3. For RTD, the maximum cable resistance allowed is 25 Ohm.
4. LCD displays temperature in degrees Celsius for RTD.
5. If one or more sensors are not used, leave the relevant terminals open.
The Actual Data display for this sensors will be "---" (Three dashes).

3.7.6 Short Circuit Protection

For “type 2 coordination”, use fuses for semiconductor protection to protect the iStart from a short circuit. Fuses for semiconductor protection give excellent results because they have low I^2t values and high interruption ratings.

3.7.6.1 Recommended fuse selection procedure:

- (1) **Fuse rated voltage:** Choose minimum fuse rated voltage which is above the rated voltage of the mains.
- (2) **Fuse rated current:** Select a fuse which is able to carry 7 times the rated iStart current for 30 seconds (this is double the maximum iStart current for the maximum acceleration time).
- (3) **Fuse I^2t :** Verify that the I^2t value of the fuse is less than or equal to the I^2t value of the thyristor in the iStart as shown in the table below.

iStart Model	Max. Thyristor I^2t [A ² Sec]	iStart Model	Max. Thyristor I^2t [A ² Sec]
17	4,750	310	845,000
31	10,250	350	845,000
44	11,300	430	1,130,000
58	108,000	515	1,820,000
72	108,000	590	1,820,000
85	108,000	690	1,820,000
105	240,000	720	1,820,000
145	240,000	850	1,820,000
170	321,000	960	4,260,000
230	135,500	1100	4,260,000

3.7.7 “Inside-Delta” Mode

3.7.7.1 General Information

When the iStart is installed “Inside Delta”, the individual phases of the Starter are connected in series with the individual motor windings (6 conductor connections as with the star-delta starter). The soft starter must only conduct about 67 % (=1/1.5) of the rated motor current. This ensures the use of a significantly smaller device.

For example:

For a motor with a rated current of 1050A motor, a 1100A starter will be selected to operate “In-Line”. For “Inside Delta” starter, we calculate (1050 x 67% = 703A) and select a 720A starter. Less heat dissipates in the cabinet vs. the standard “In-Line” connection.

Note :

For a high starting torque process, it is recommended to use the starter in the “In Line” connection.

3.7.7.2 Notes on “Inside Delta” Connection

- “Inside Delta” requires 6-wires to the motor.
- Wrong motor connection will cause serious damage to the motor windings.
- When installing the iStart “inside delta” it is highly recommended to use a contactor in series to the ISTART or upstream of the motor in order to avoid a destruction of the motor in case of a shorted SCR in the ISTART.
- The sinusoidal shape of the current is imperfect (since each phase is separately fired and not influenced by other phase firing).
As a result, higher harmonic content is incurred (THD), which can be as high as twice the THD value as in the standard “In-Line”.
- Higher motor heating is expected for the same motor size (due to the higher THD).
- Phase sequence must be correct; otherwise, “Phase Sequence fault” will trip the starter immediately (without any damage).
- Higher torques cannot be obtained.
- When “Inside Delta” mode is configured:
 - No Pulse Start.
 - No curve selection (Curve 0 !! only).

- No Slow Speed (Reverse and Forward).
- No Phase sequence “Off” mode.
- No 2-phase control.

WARNINGS!	<u>Beware!</u> Wrong connection of the starter or the motor, will seriously damage the motor.
	When using “Inside delta” connection: 1. It is highly recommended to use a contactor in series to the ISTART or upstream of motor in order to avoid a destruction of the motor in case of a shorted SCR in the ISTART. 2. If Contactor is connected Inside the Delta, motor terminals are “live” (full voltage) even when contactor is open.

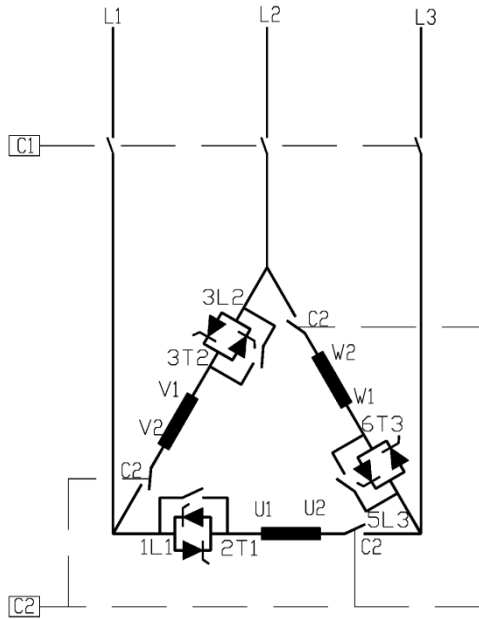

ISTART connected INSIDE DELTA

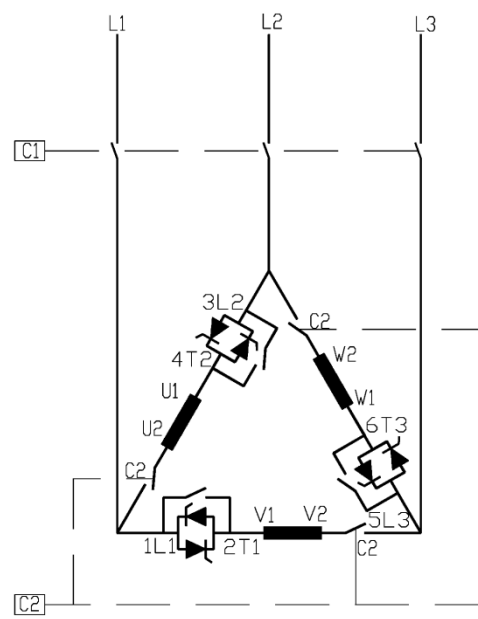

Speed reverse with ISTART connected INSIDE DELTA

- (1) C1 is a line contactor.
 - (2) C2 is an “Inside Delta” contactor.
 - (3) U1-U2, V1-V2, W1-W2 are motor’s windings.
 - (4) L1-U, L2-V, L3-W are iSTART controlled phases.
- Refer also to section 3.6 on page 15.

Note:

Motor terminals are marked as follows:

ASA (USA)	BS	VDE	IEC
T1 - T4	A1-A2	U - X	U1 - U2
T2 - T5	B1-B2	V - Y	V1 - V2
T3 - T6	C1-C2	W - Z	W1 - W2

4. Dimensions

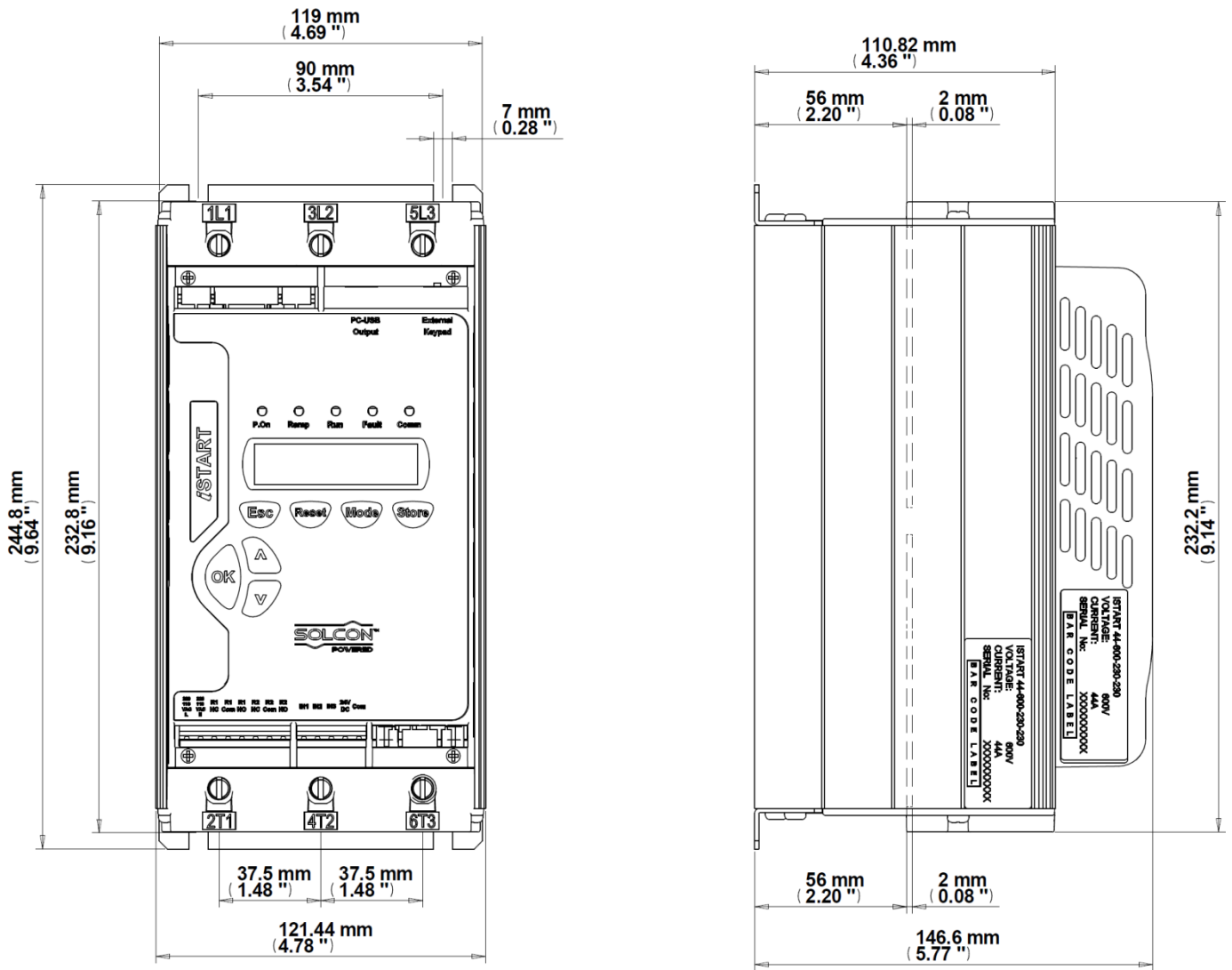

iStart Size A: 17A, 31A, 44A (Without fan box)

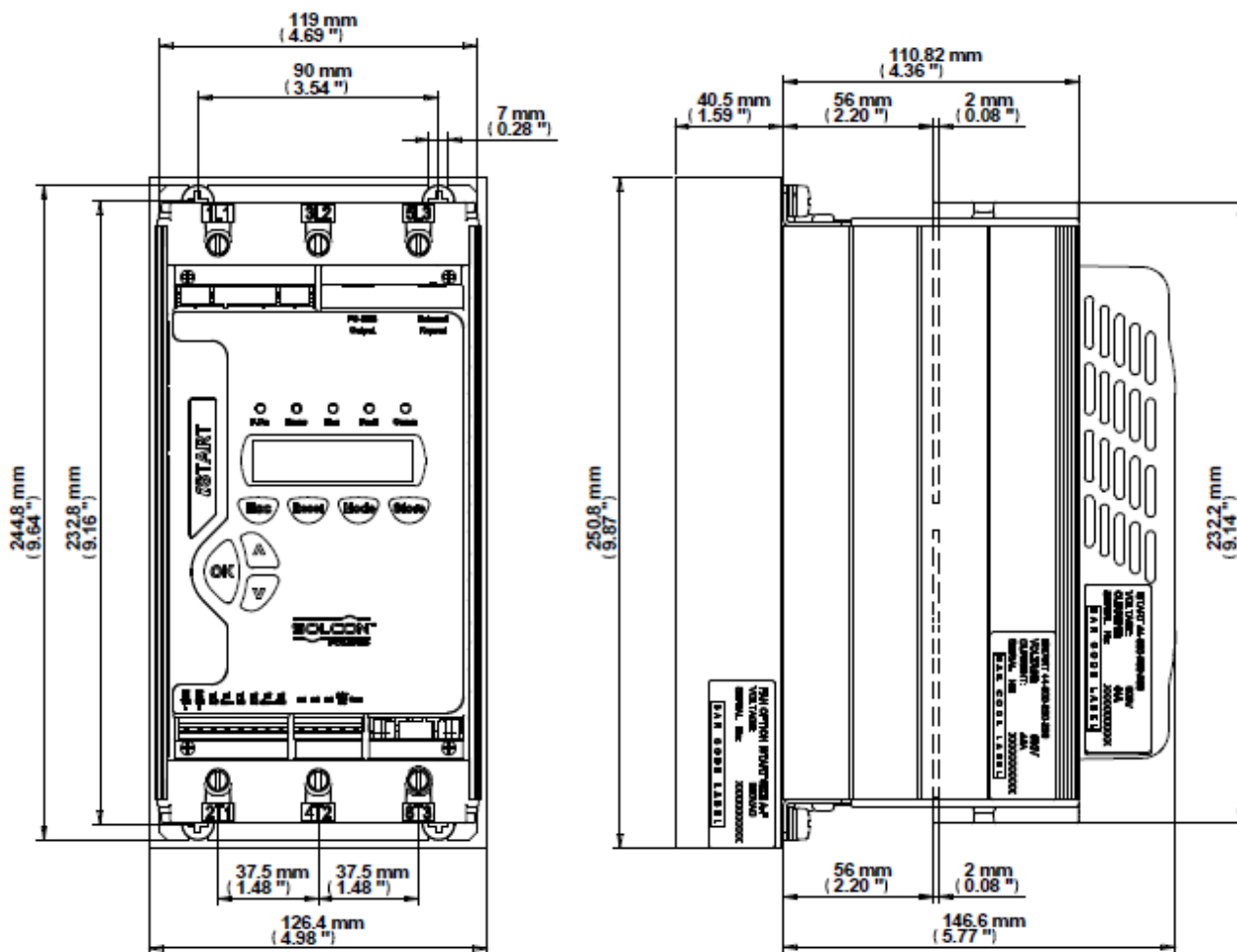

iStart Size A: 17A, 31A, 44A (Fan box included)

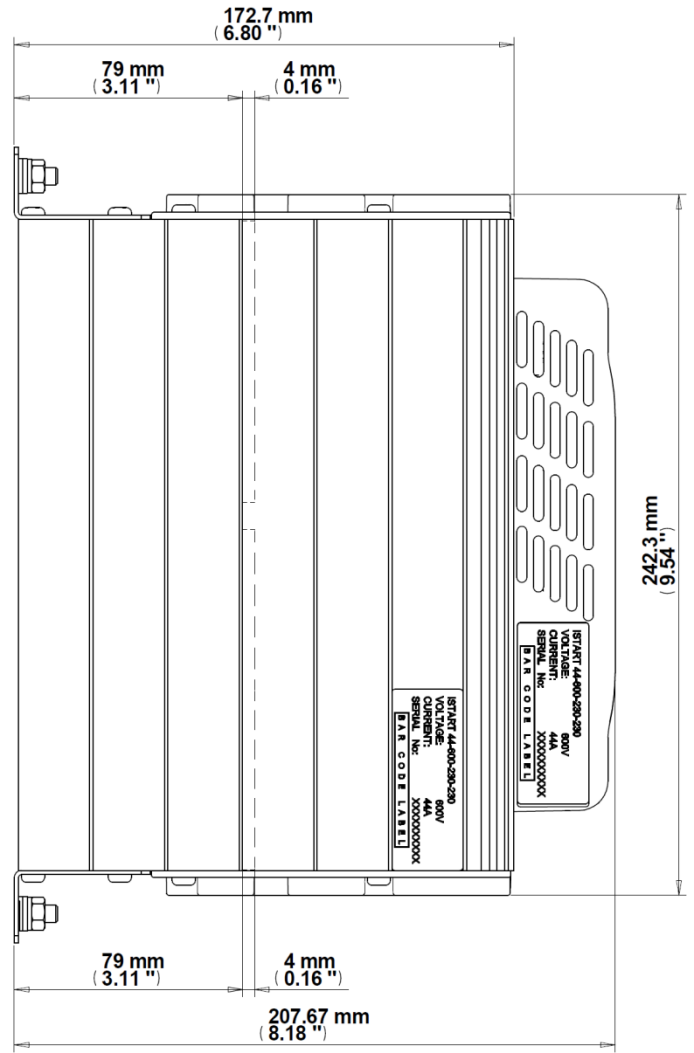
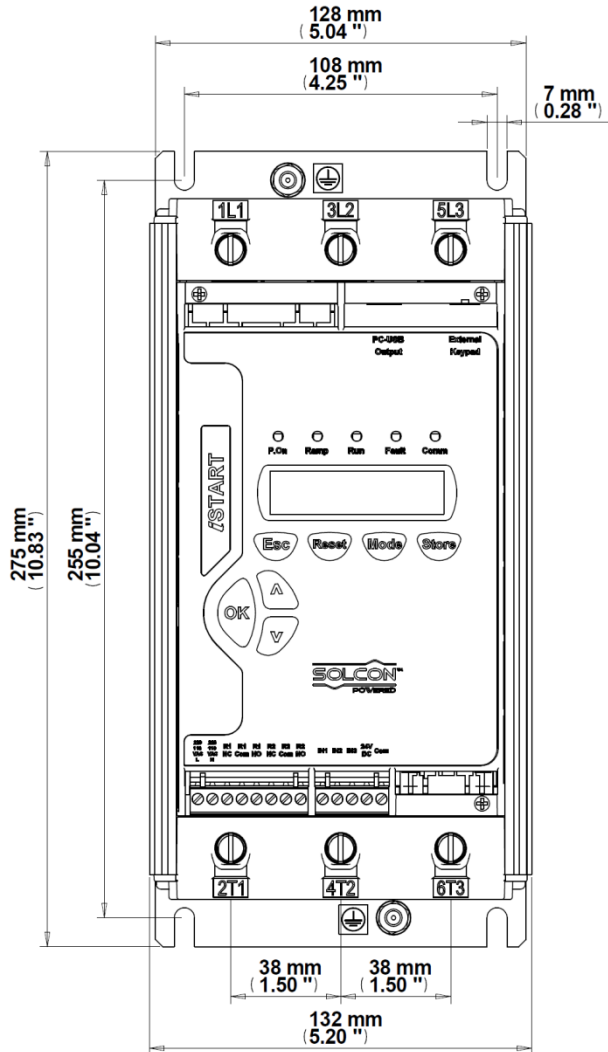

iStart Size B: 58A, 72A, 85A (Without fan box)

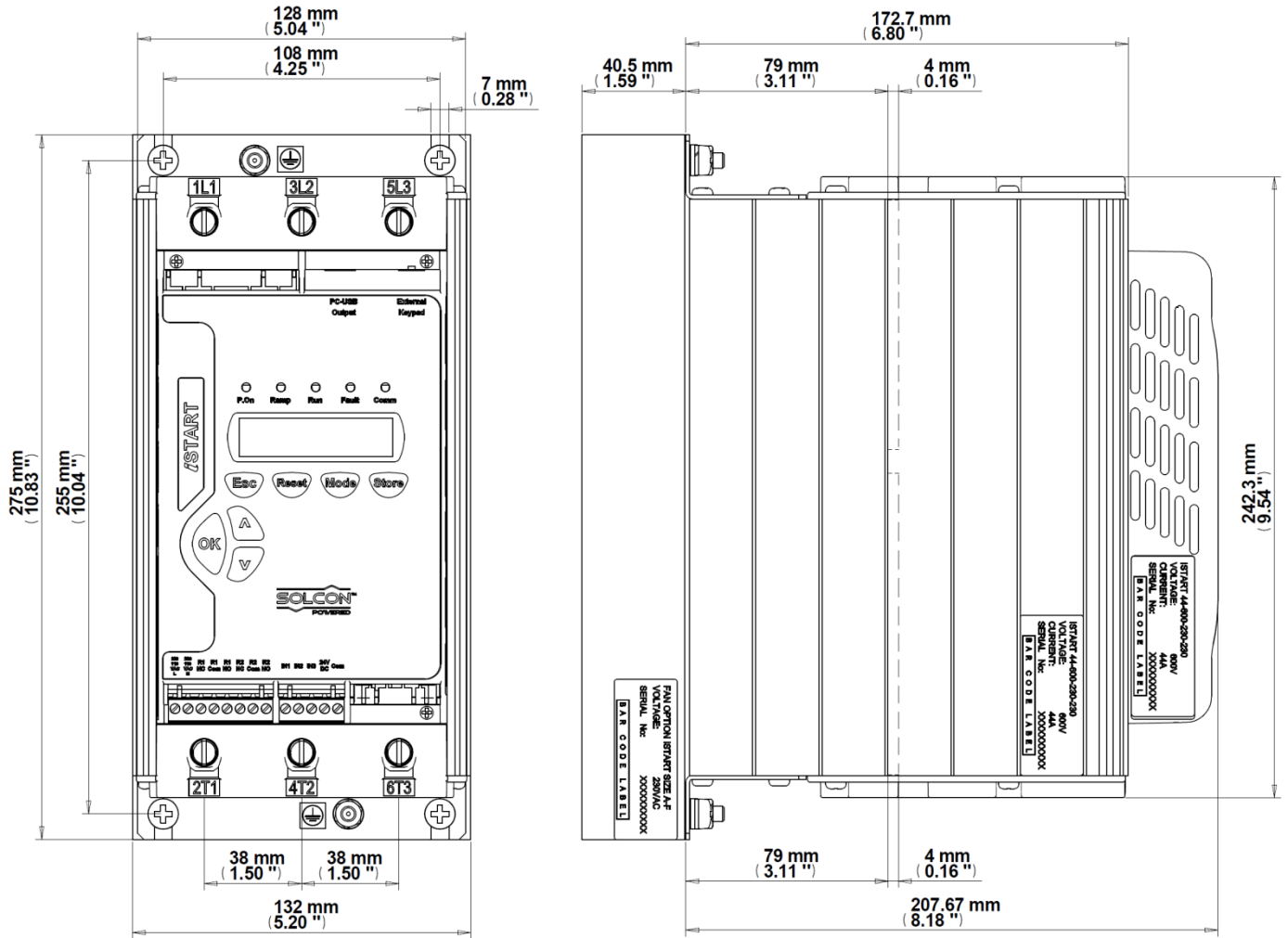

iStart Size B: 58A, 72A, 85A (Fan box included)

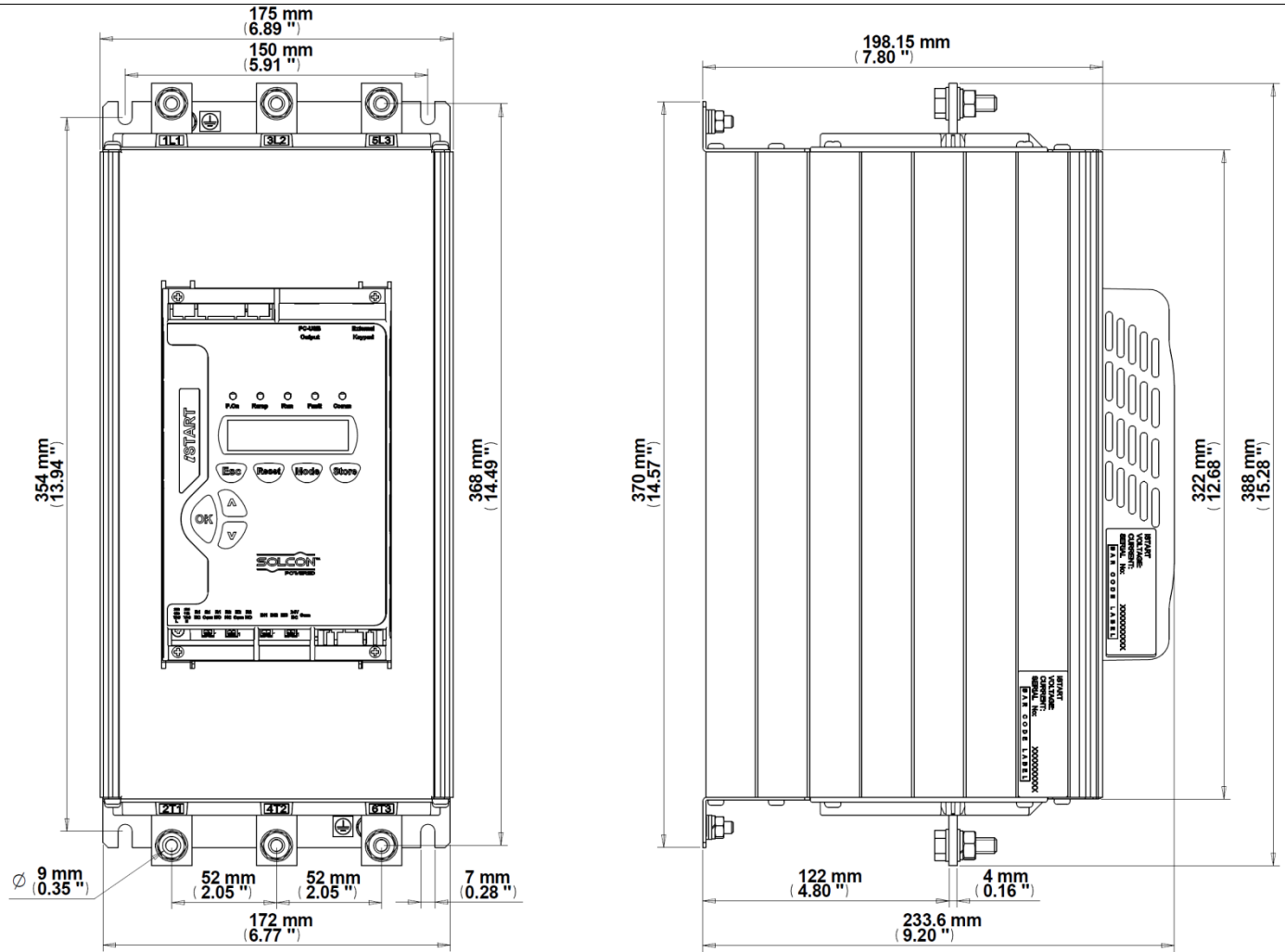

iStart Size C: 105A, 145A, 170A (Without fan box)

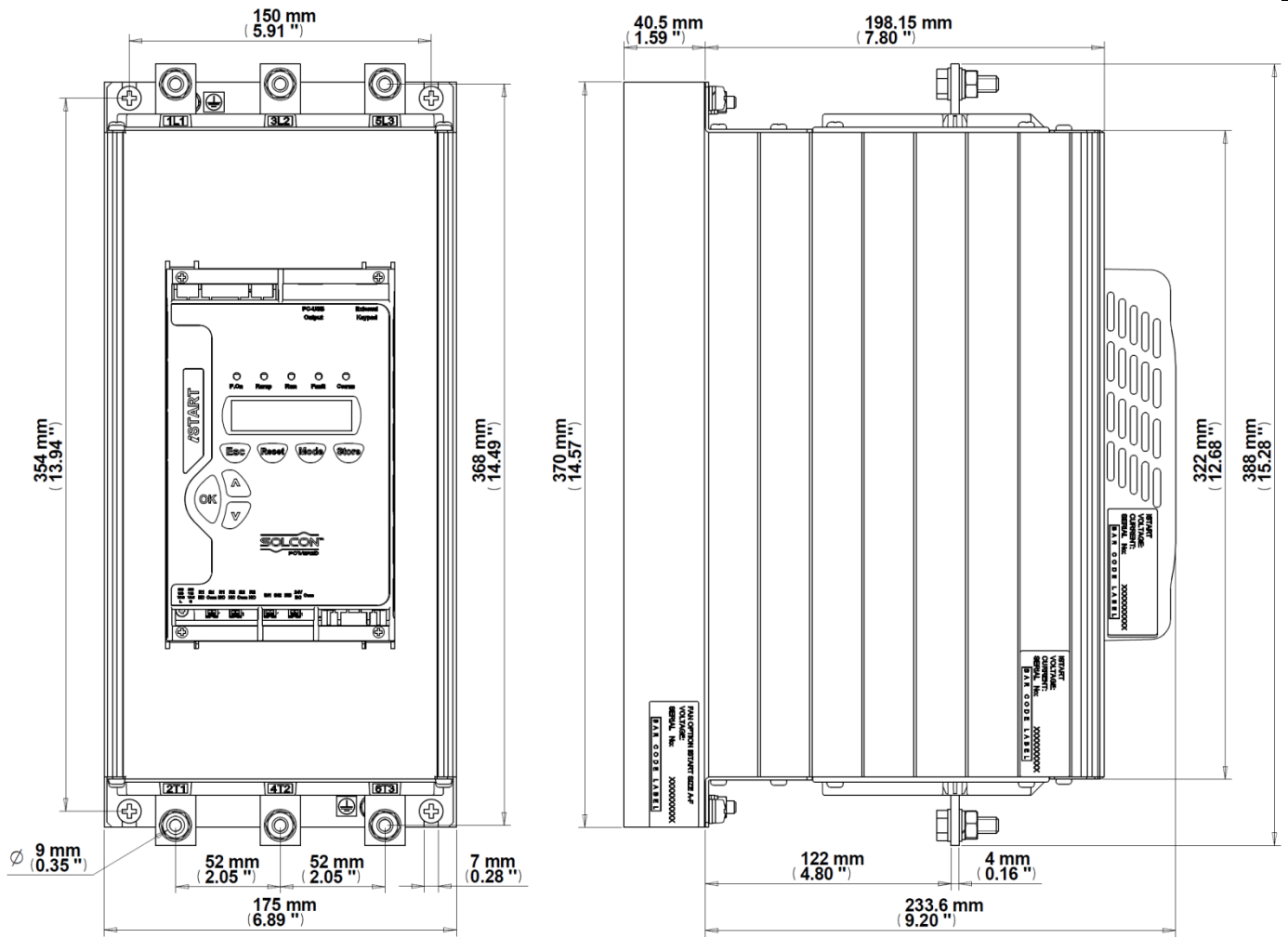

iStart Size C: 105A, 145A, 170A (Fan box included)

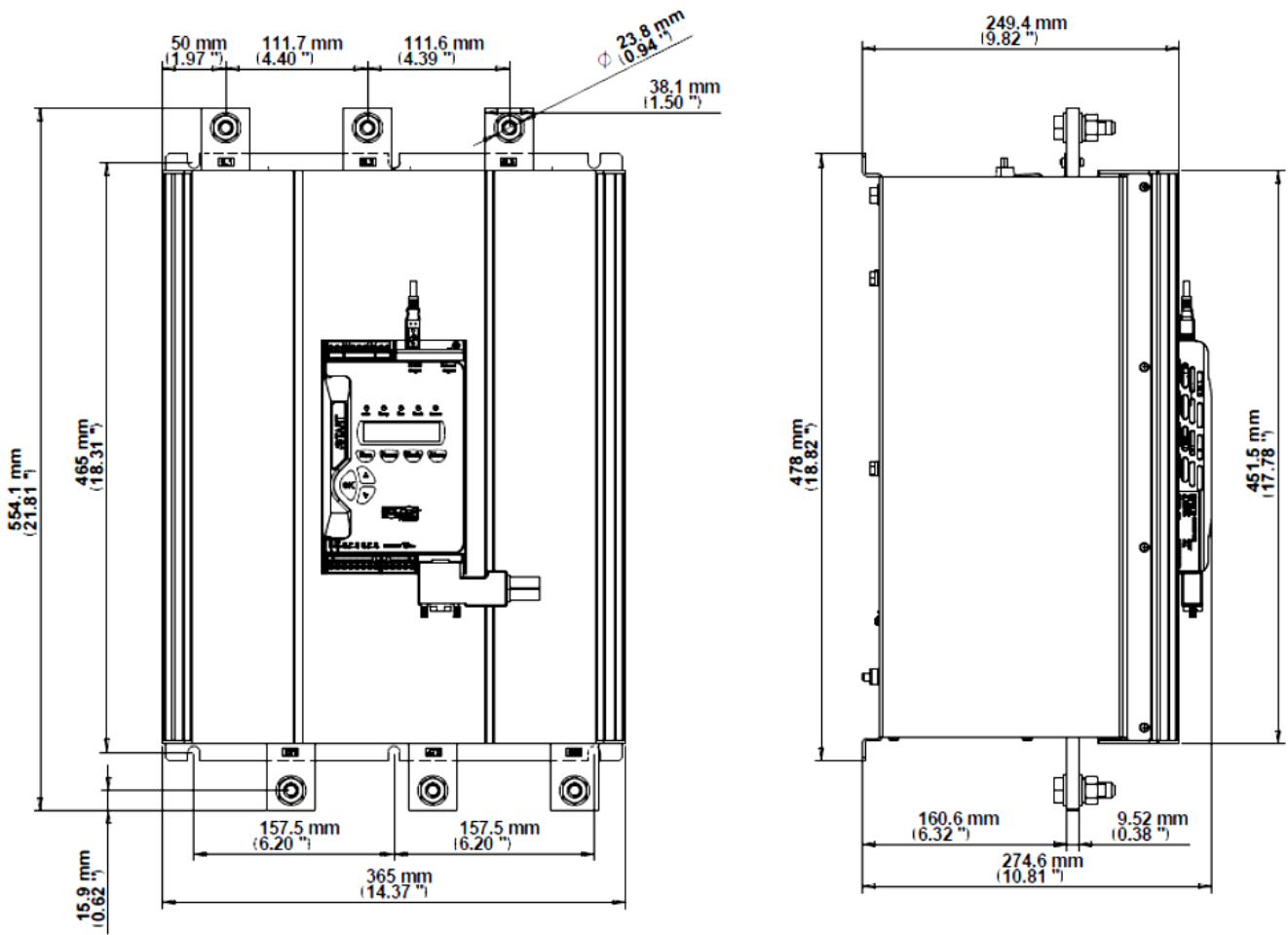

iStart Size D : 230A, 310A, 350A

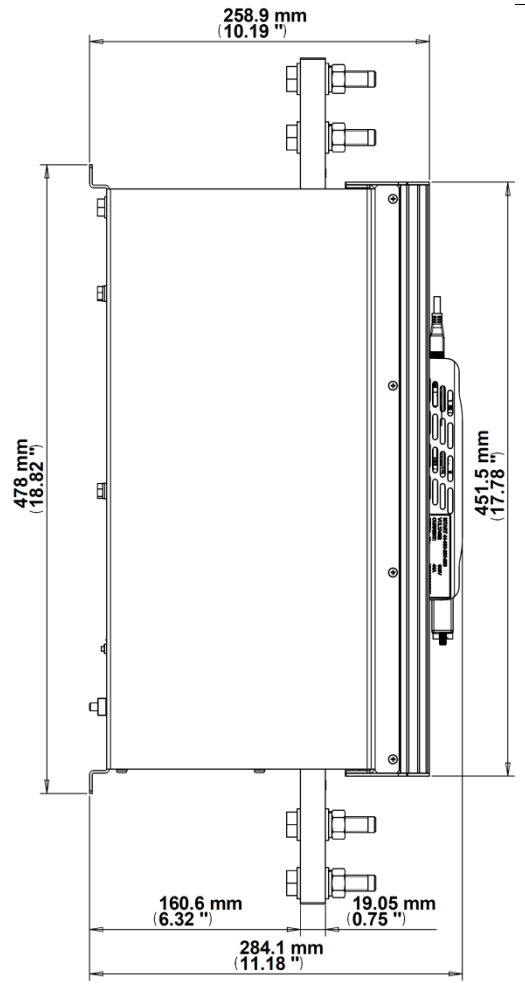
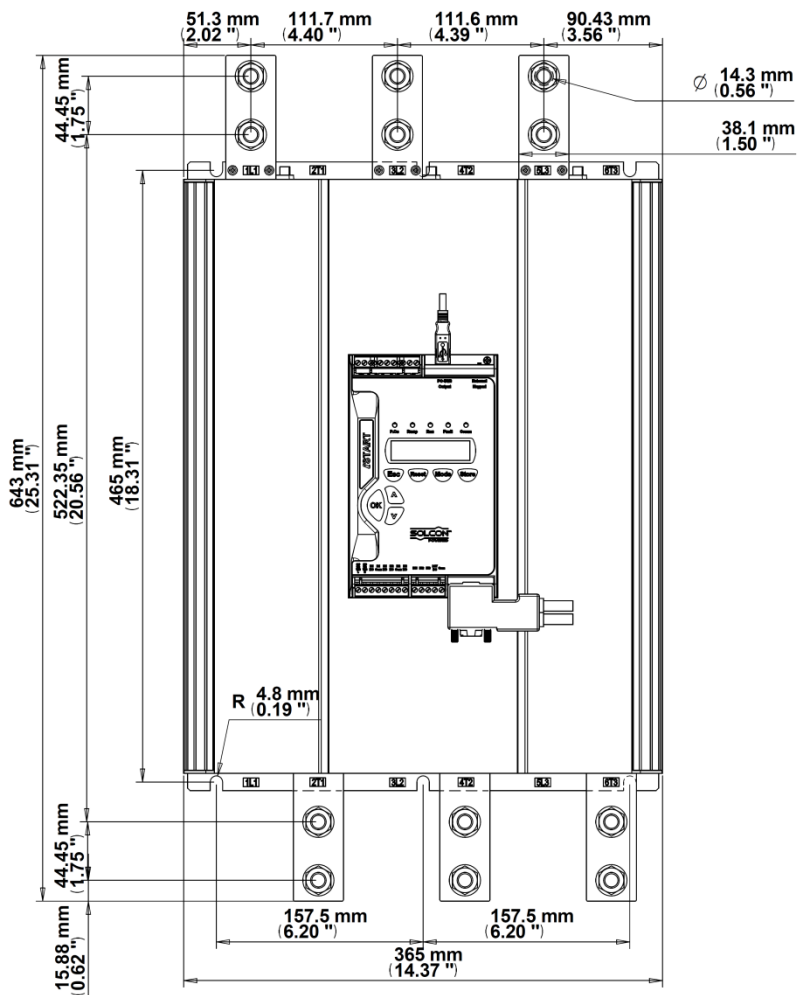

iStart Size E : 430A

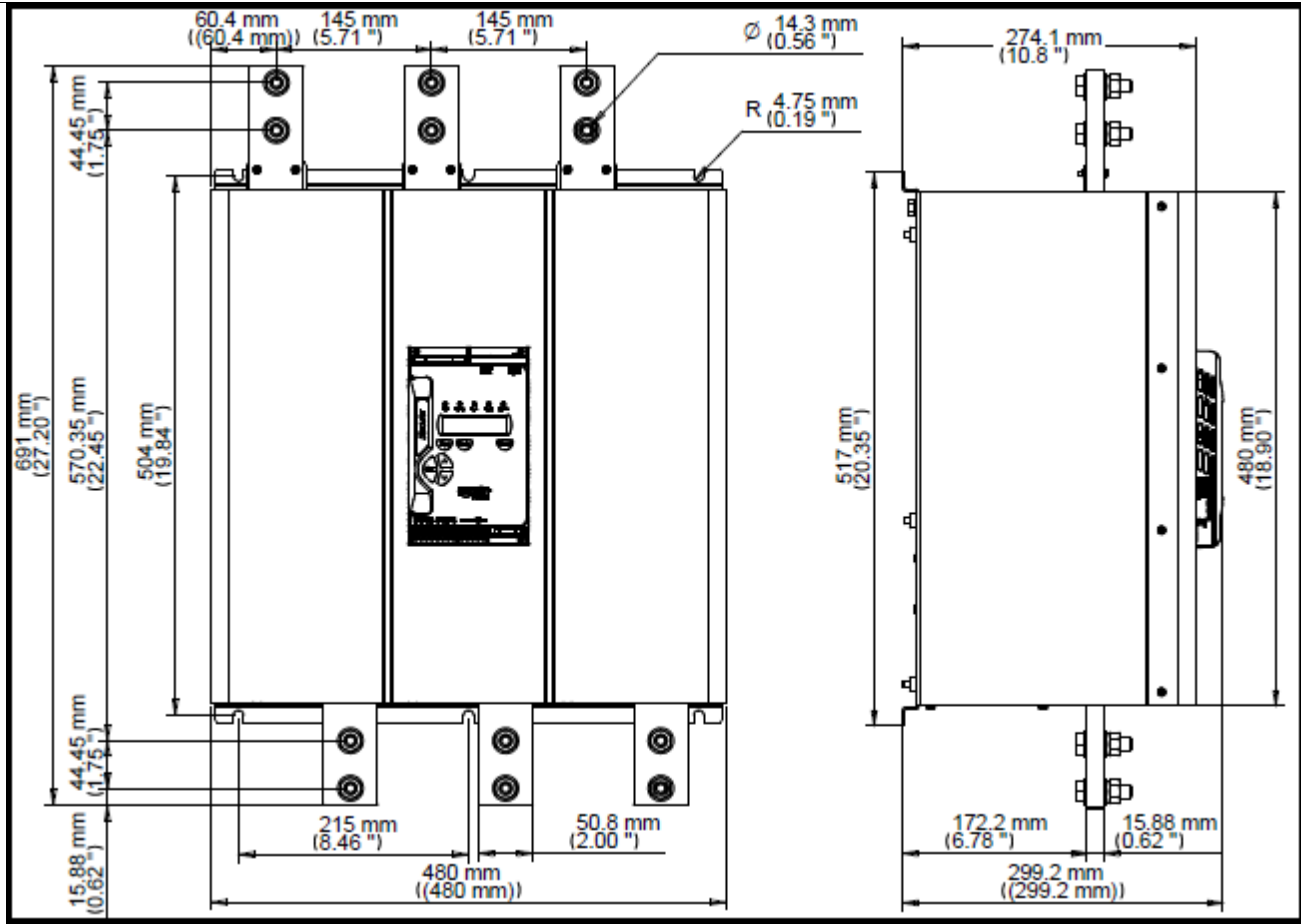

iStart Size F : 515A

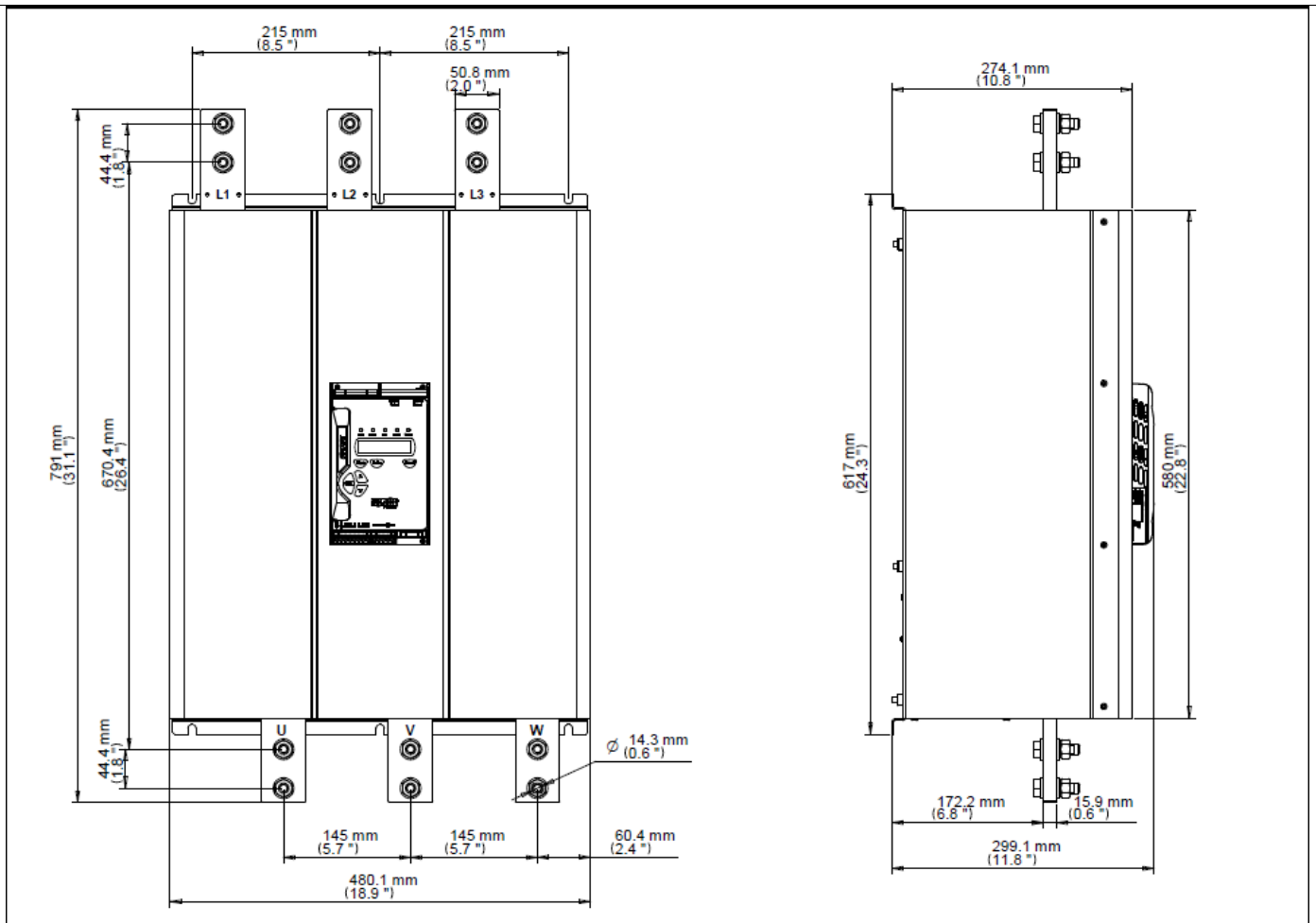

iStart Size G : 590A, 690A

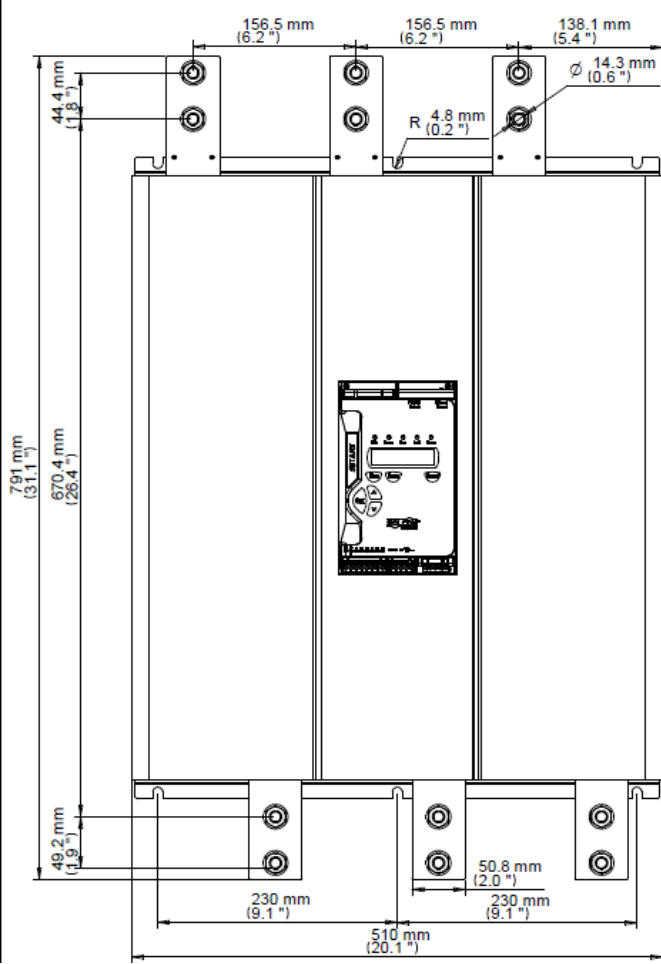

iStart Size H : 720A, 850A

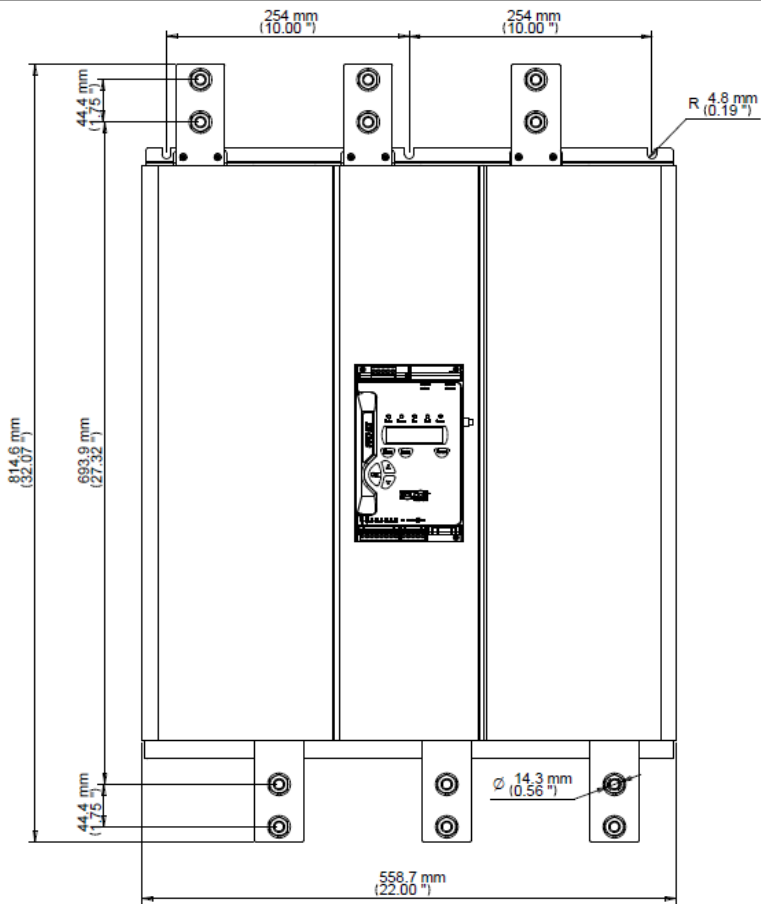

iStart Size I : 960A, 1100A

5. INSTALLATION

WARNING!

Do not interchange line and load connections

5.1 Prior to Installation

Check that Motor's Full Load Ampere (FLA) is lower than, or equal to the starter's Full Load Current (FLC) and that Mains and Control voltages are as indicated on the starter's side label.

Make sure Starter's $FLC \geq$ Motor FLA!



Make sure Starter's $FLC \geq$ Motor FLA!

Make sure Control voltage is right!

ISTART label - example

5.2 Mounting

The starter must be mounted vertically. Allow sufficient space (at least 100mm) above and below the starter for suitable airflow.

It is recommended to mount the starter directly on the rear metal plate for better heat dissipation.

Note:

Do not mount the ISTART directly on the rear metal plate in case a ventilation fan or ventilation opening is on the back side of the ISTART.

Do not mount the starter near heat sources.

Surrounding air temperature in the cabinet should not exceed 40°C.

Protect the starter from dust and corrosive atmospheres.

Note: For harsh environments (sewage treatment plants, etc.), it is recommended to order the starter with option 8 (harsh environment treatment) printed circuit board coating. Refer to section 2.3.3 on page 9 for ordering information.

5.2.1 IP-54 Remote Keypad Installation

3D VIEW WITHOUT DOOR

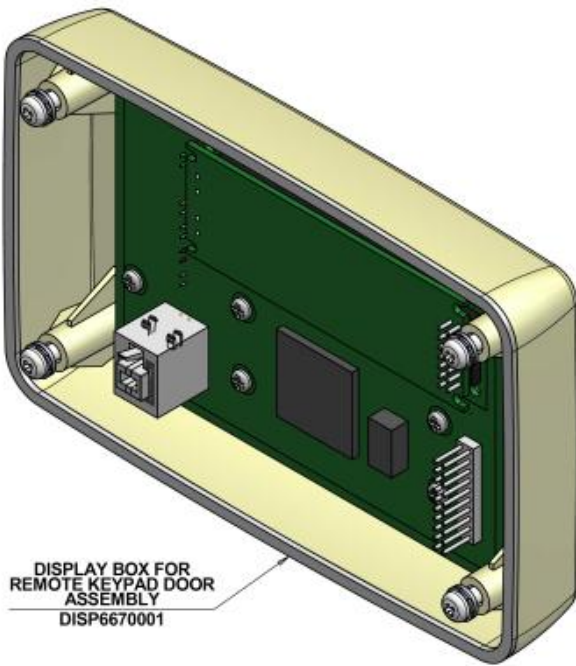

DISPLAY BOX REAR VIEW
WITHOUT DOOR

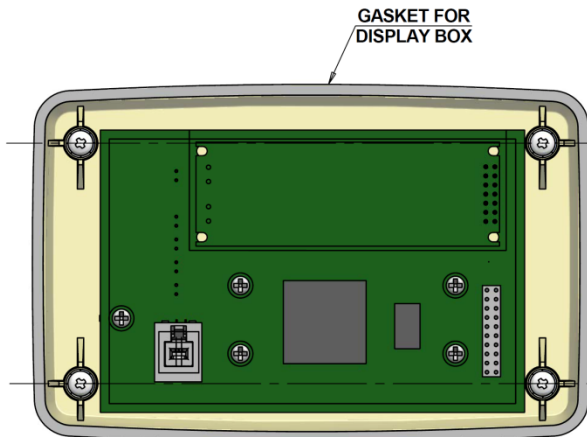

DOOR FRONT VIEW

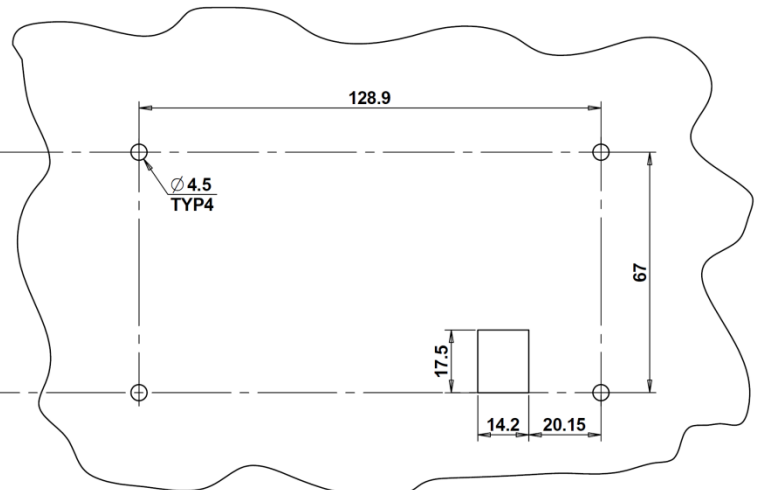

Figure 4: Dimensions for installing the remote keypad

5.3 Temperature Range & Heat Dissipation

The starter is rated to operate over a temperature range of -10°C (14°F) to +40°C (104°F). Relative non-condensed humidity inside the enclosure should not exceed 95%.

ATTENTION!

Operating at surrounding air temp. (Inside the cabinet) higher than 50°C may cause damage to the starter.

Starter's heat dissipation while motor is running and the internal bypass relays are closed is typically less than $0.4 \times I_n$ (in watts). During soft start and soft stop, heating is approximately three times the actual starting current (I_n watts).

Example: For a 100A motor, heat dissipation is less than 40 watts while running and during starting (for example at 350A), heat dissipation is approximately 1050 watts.

Important note: If motor is frequently started, cabinet should be designed for the higher heat dissipation.

Internal enclosure heating can be reduced through the use of additional ventilation.

5.3.1 Calculating the Enclosure Size, for Non-Ventilated Metallic Enclosure

$$\text{Area (m}^2\text{)} = \frac{0.12 \times \text{Total heat dissipation [Watts]}}{60 - \text{External ambient temp. [}^\circ\text{C]}}$$

Where: **Area [m²]** - Surface area that can dissipate heat (front, sides, top).

Total heat dissipation [Watt] – The total heat dissipation of the starter and other control devices in the enclosure. If starter is frequently started, average power should be used.

5.3.2 Additional Ventilation

Use the following arrangement for forced ventilation of the ISTART's enclosure:

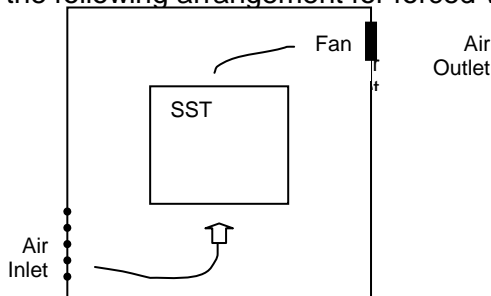

5.4 Installing an Option Card

Option cards are either factory installed or sent separately for customer upgrade. If you perform your own upgrade make sure to read and perform the preinstallation instructions in section 5.4.1.

5.4.1 Preinstallation Instructions for Installing an Option Card

Step 1: Make sure that you have the following available:

- A cutter
- ESD ground protection
- The option card. **Do Not remove the option card from its antistatic bag yet.**

Step 2: Shut down all power to the iStart unit (mains and control voltage).

Step 3: Disconnect all cables and connectors that are attached to the control panel.

5.4.2 Opening the Control Panel

Step 1: Remove the 4 screws that hold the plastic housing of the iStart control panel to the power unit.

Step 2: Ground yourself with ESD protection.

Step 3: Remove the 6 screws that hold the PCB card to the plastic housing of the control panel.

5.4.3 **Removing the Connector Cover**

Before you insert the option card, you must cut off the part of the housing that covers option card connections. For analog cards, cut off the covering at the top of the plastic housing. For communication cards, cut off the covering at the bottom of the plastic housing.

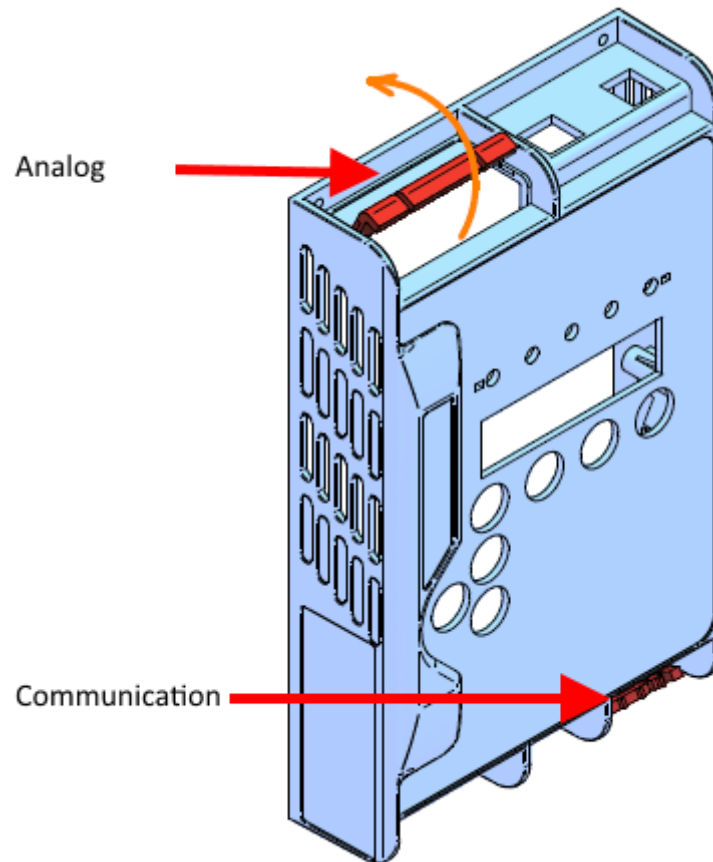

Figure 5: Removing the connector cover

5.4.4 Inserting the Option Card and Closing the Unit

- Step 1: Remove the PCB card and turn it over.
- Step 2: Remove the option card from the antistatic bag.
- Step 3: Detach the connector from the option card.
- Step 4: If you are installing the **Thermistor in and Analog out** card, set the dip switches. Refer to 5.5 Setting the Thermistor In and Analog Out Option Card. You can use a pen or pencil to do this.
- Step 5: Attach the option card to the correct header connector. Make sure that it is firmly attached. Use J1 for the analog option cards and J6 for the communication option cards.
- Step 6: Put the PCB card back in the plastic housing of the iStart control panel.
- Step 7: Replace the 6 screws that hold the PCB card to the plastic housing.
- Step 8: Reconnect the connector that you removed in step 3.
- Step 9: Put the plastic housing back on the power unit and replace the 4 screws that hold it in place.

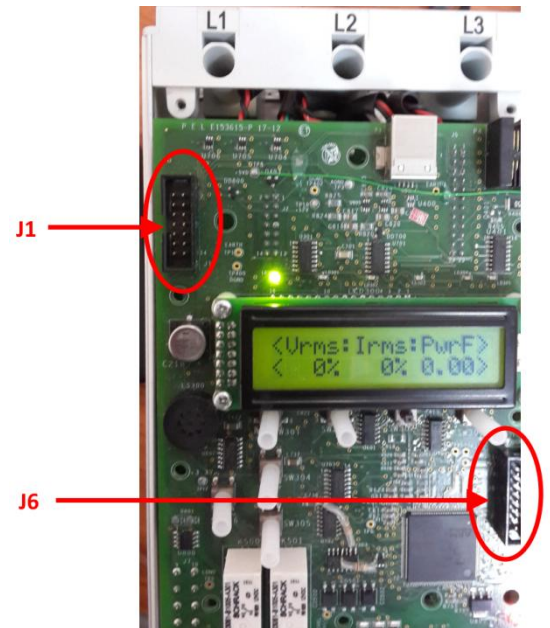

Figure 6: Location of the header connectors J1 and J6

- Step 10: Reconnect all cables and connectors that you removed.
- Step 11: Add the connections to the relevant option card. Refer to section 3.7 Option Card Connections on page 16.

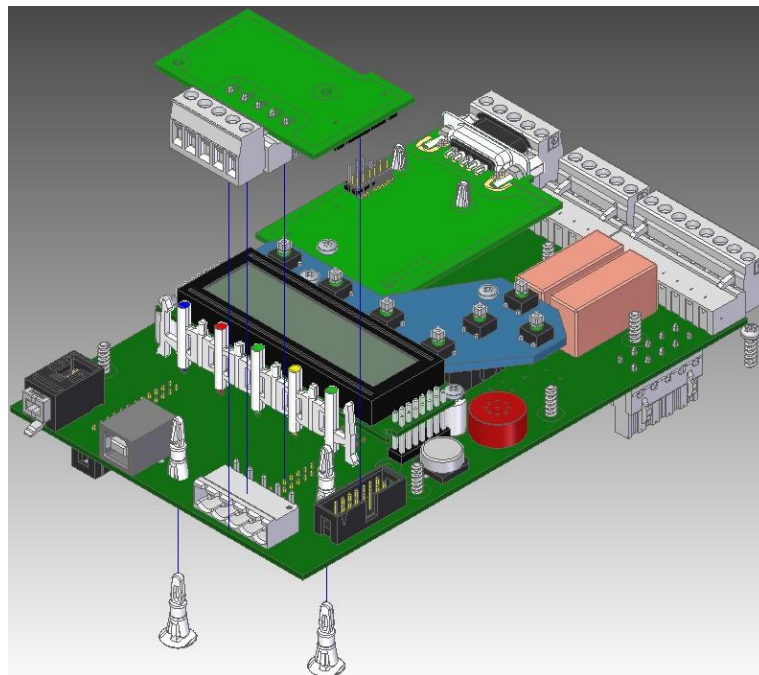

Figure 7: Inserting an option card - overview

5.5 Setting the Thermistor In and Analog Out Option Card (Option 5)

The Analog option contains two independent parts: Thermistor Input and Actual Data Output. The operator can place one or more PTC or NTC thermistors on the motors windings or other critical areas. The operator is responsible for using the thermal sensors according the manufacturer’s instructions. The Analog Output enables the output of the following types of actual data:

- Vrms - Voltage (RMS value). This is the default output.
- Irms - Current (RMS value)
- Power factor
- Power

- Step 1: Remove the orange plastic that covers the dip switches.
 Step 2: Set the dip switches according to the setting that you need.



Figure 8: Location of the dip switches on the Thermistor In and Analog Out option card

Dip switch settings

Current (0 – 20mA / 4 – 20mA)

SW	SW1	SW2	SW3	SW4
ON		ON		OFF
OFF		ON		OFF

Voltage (0 – 10V)

SW	SW1	SW2	SW3	SW4
ON		OFF		ON
OFF		OFF		ON

- Step 3: Make sure that control power and mains voltage are off.
 Step 4: Install the analog card. Refer to section 5.4.4on page 35 .
 Step 5: Set the parameters:
1. Turn on control power, press the DATA key once, followed by the down key.
 This will take you to the following menu:

ANALOG OPTION
THERMISTOR INPUT

2. Press ENTER.
 This will take you to the following menu:

OUTPUT OPTION
Vrms OUTPUT

3. Select the desired analog ouput. The next parameter will be the CURRENT RANGE.
4. Set the CURRENT RANGE. The options are:
 - 0-20mA
 - 4-20mA

Important: When using the card in VOLTAGE mode, you must set this parameter to 0-20mA.

5. The next parameter is THERMISTOR TYPE. Set the PTC (default) or NTC.
6. The next parameter is LIMIT RESISTANCE. If the resistance exceeds the max/min resistance defined, the iStart will trip.
 You can set this parameter from 100 Ohm to 30000 Ohm.

5.6 Setting the Analog Option – 3XRTD Thermal Sensor Option Card (Option 6)

The Analog option enables the placement of up to 3 RTD thermal sensors on the motor's winding or other critical areas. **The thermal sensors must be of the PT100 type.** The operator is responsible for using the thermal sensors according to the manufacturer's instructions.

Step 1: Make sure that control power and mains voltage are off.

Step 2: Install the analog card. Refer to section 5.4.4 on page 35.

Step 3: Turn on control power, press the DATA key once, followed by the down key.

This will take you to the following menu:

```
ANALOG OPTION
TEMP.RELAY-3IN
```

Step 4: Press ENTER.

This will take you to the following menu:

```
MAX TEMPERATURE
120 C
```

Step 5: Set the maximum temperature. This parameter determines the maximum measured temperature allowed. If the temperature exceeds the max/min temperature defined, the iStart will trip. You can set this parameter from -20°C to 200°C.

Step 6: Connect the PT100 between P1.1 and P1.2, and connect P1.2 and P1.3 without any resistance (short-circuit). If P2 and P3 are in use, do the same for them. Refer to section 3.7.5 on page 17.

Step 7: In order to see the RTD reading, press DATA and use the arrows until you see the RTD TEMPERATUR screen as in the example below:

```
<RTD TEMPERATUR>
<54C 54C 54C>
```

If all three inputs are not connected, the missing sensor(s) will display as --- as in the example below:

```
<RTD TEMPERATUR>
<--- --- 54C>
```

5.6.1 PT100 [C°/Ω] Table

Temperature [in °C]	Pt100[in Ω] - Typ: 404	Temperature[in °C]	Pt100[in Ω] - Typ: 404
-50	80.31	40	115.54
-45	82.29	45	117.47
-40	84.27	50	119.4
-35	86.25	55	121.32
-30	88.22	60	123.24
-25	90.19	65	125.16
-20	92.16	70	127.07
-15	94.12	75	128.98
-10	96.09	80	130.89
-5	98.04	85	132.8
0	100	90	134.7
5	101.95	95	136.6
10	103.9	100	138.5
15	105.85	105	140.39
20	107.79	110	142.29
25	109.73	150	157.31
30	111.67	200	175.84

Temperature [in °C]	Pt100[in Ω] - Typ: 404	Temperature[in °C]	Pt100[in Ω] - Typ: 404
35	113.61		

6. CONTROL KEYPAD

The control keypad is the link between the iStart and the user.

The iStart control keypad features:

- (1) Indication LEDs (*On, Ramp, Run, Fault, Comm*)
- (2) Two lines of 16 alphanumeric characters each with selectable languages – English, German, Spanish and French. Russian and Chinese characters are optional and must be pre-ordered. By default the display shows actual data.
- (3) Six push-buttons (**Data, Reset, Esc, Enter**, Up (**▲**) and down (**▼**) keys).

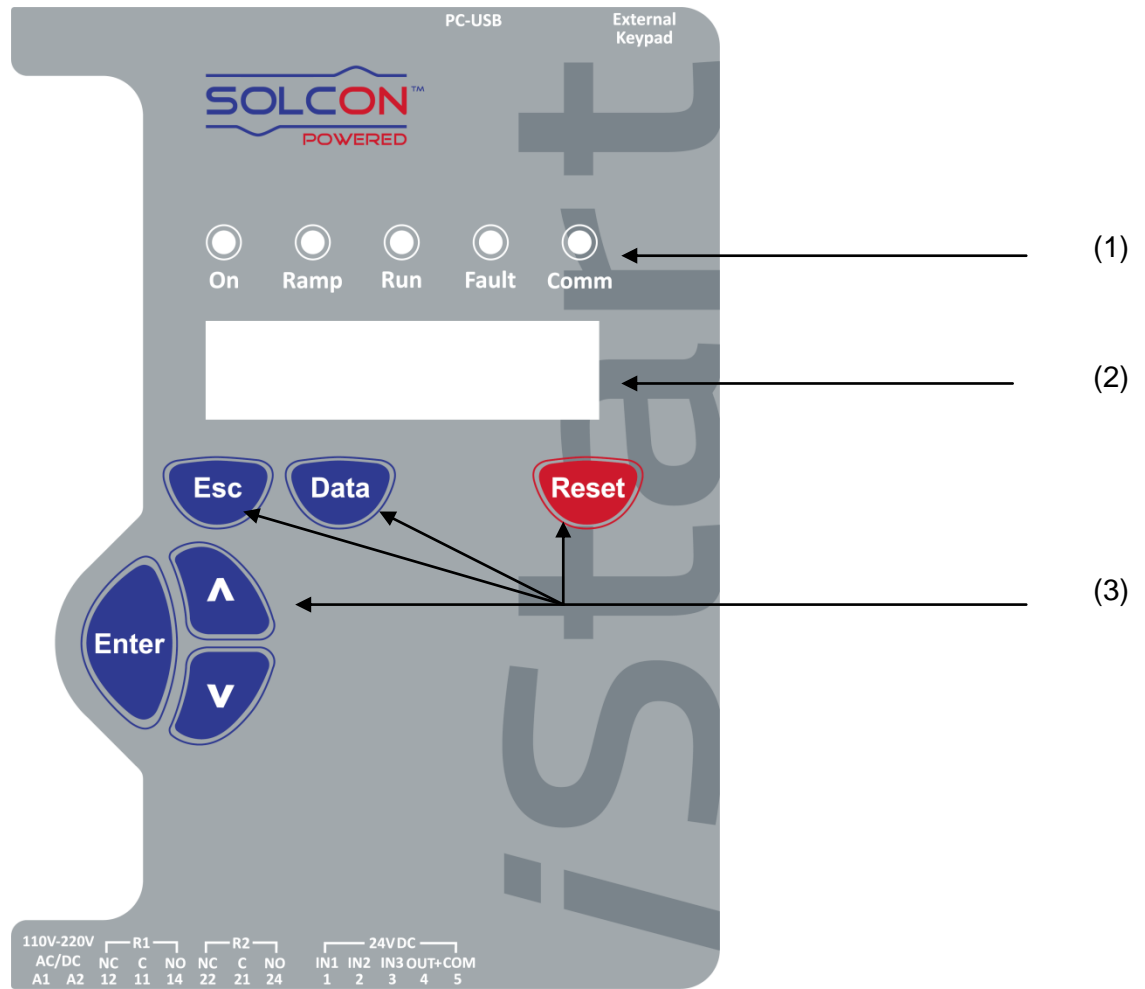

6.1 LCD Arrangement

CURRENT LIMIT 390 % FLA

Upper line displays function.





Lower line displays setting and/or measured values.

< > indicates actual data in display mode.

6.2 Push-Buttons

Esc	<ul style="list-style-type: none"> Exits the current menu and returns to the previous menu without save.
Data	<ul style="list-style-type: none"> Toggles between the view of actual data and parameter settings. Actual data appears inside arrow brackets as shown below. < Actual Data Type > < Actual Data Value > Parameters are shown without arrow brackets. After a one minute timeout, the display returns to the actual data view.
▲	<ul style="list-style-type: none"> Scrolls to the previous menu. Allows the operator to increment adjusted values shown in the display. Press this button once to increment one value, or continuously to rapidly increment values up to the maximum value.
▼	<ul style="list-style-type: none"> Scrolls to the following menu. Allows the operator to decrement adjusted values shown in the display. Press this button once to decrement one value, or continuously to rapidly decrement values up to the minimum value.
Enter	<ul style="list-style-type: none"> When a menu name is displayed, pressing this button drills down to the parameters for that menu. When a parameter is displayed, pressing this button makes the parameter value editable (value blinks). Use the up/down arrows to change the value. When the parameter value blinks, pressing Enter saves the parameter value.
Reset	<ul style="list-style-type: none"> Resets the iStart after a fault has been dealt with and the start command has been removed. This cancels the fault displayed and allows you to restart the motor.

6.3 Status LEDs

	Green	<i>On</i>	Lights when the control supply voltage is connected to the iStart.
	Yellow	<i>Ramp</i>	Lights during soft start, indicating that motor supply voltage is ramping up.
	Green	<i>Run</i>	Lights after completion of the starting process, indicating that motor is receiving full voltage.
	Red	<i>Fault</i>	Lights upon operation of any of the built-in protections. <ul style="list-style-type: none"> Lights constantly when a trip occurs. Blinks when a warning occurs.
	Blue	<i>Comm</i>	Blinks when there is an active communication link.

6.4 Reviewing Parameters

- Press the **Data** key to toggle from actual data view to the parameter menus.
- Press **Esc** twice to get to the Main Parameters menu.
- Use the **▼** or **▲** keys to navigate to the parameter menu that you need.
- Press **Enter** to enter the menu.
- Use the **▼** or **▲** keys to navigate to the relevant parameter.

6.4.1 Modifying the Parameter

- Press **Enter** to make the parameter value editable (value blinks).
- Use the **▼** or **▲** keys to change the value.
- Press **Enter** to save the value (value stop blinking).

6.5 Special Actions Performed in TEST/MAINTENANCE Mode

6.5.1 View Firmware Version/Version Date/Version CRC16

- Press the **Data** key to toggle from actual data view to the parameter menus.
- Press **Esc** twice to get to the Main Parameters menu.
- Press and hold the **▼** key until you reach the last menu (TEST/MAINTENANCE). The LCD will display:

```
TEST/MAINTENANCE
- **** -
```

- Press the **Enter** key. The LCD will display the Firmware version number (e.g. 4.000):

```
VERSION NUMBER:
4.000
```

- Press the **▼** key. The LCD will display the Firmware version release date (e.g. 08/07/2014):

```
VERSION DATE:
08/07/2014
```

- Press the **▼** key. The LCD will display the Firmware version CRC16 – 16 bits cyclic redundancy check (e.g. A165):

```
VERSION CRC16:
A165
```

This is the Firmware version unique I.D. number.

6.5.2 Reset to Factory Default Parameters

- Press the **Data** key to toggle from actual data view to the parameter menus.
- Press **Esc** twice to get to the Main Parameters menu.
- Press and hold the **▼** key until you reach the last menu (TEST/MAINTENANCE). The LCD will display:

```
TEST/MAINTENANCE
- **** -
```

- Press **Enter**.
- Use the **▼** key to navigate to the RESET SETTING!!! menu. The LCD will display:

```
RESET SETTING!!!
ENTER TO DEFAULT
```

- Press **Enter** to enter the menu. The LCD will display:

```
RESET SETTING!!!
* * * N O * * *
```

- Press the **▲** key. The LCD will display:

```
RESET SETTING!!!
* * * Y E S * * *
```

- Press **Enter**. For a short interval, the LCD will display:

```
##### RESET SETTING!!!
##### SETTING DEFAULT
```

- Press **Esc**.

CAUTION!	<p>RESET SETTING erases all previously modified settings and requires the operator to reprogram all parameters that differ from the factory default.</p> <p>Note (only at FW versions 3.007 - 3.008) : It is especially important to reprogram the RATED LINE VOLT. value again.</p>
-----------------	--

6.5.3 *Reset Statistical Data*

- Press the **Data** key to toggle from actual data view to the parameter menus.
- Press **Esc** twice to get to the Main Parameters menu.
- Press the **▼** key until you reach the STATISTICAL DATA menu. The LCD will display:

```
STATISTICAL DATA
- **** -
```

- Press **Enter**.
- Use the **▼** key to navigate to the RESET STATISTICS!!! menu. The LCD will display:

```
RESET STATISTICS
ENTER TO RESET
```

- Press **Enter** to enter the menu. The LCD will display:

```
RESET SETTING!!!
* * * N O * * *
```

- Press the **▲** key. The LCD will display:

```
RESET SETTING!!!
* * * Y E S * * *
```

- Press **Enter**. For a short interval, the LCD will display:

#####	RESET STATISTICS
#####	SETTING DEFAULT

6.6 Overview of All Mode Pages and Factory Defaults²

MAIN PARAMETERS - **** -	START/STOP ADJ. 1ST ADJUST ³	START/STOP 2ND ADJUST	START/STOP 3RD ADJUST ⁴	START/STOP 4TH ADJUST ⁵	SPECIAL FEATURES - **** -
Display and default values	Display and default values	Display and default values	Display and default values	Display and default values	Display and default values
SET LANGUAGE ENGLISH	MOTOR FLA 44 AMP	MOTOR FLA 44 AMP	MOTOR FLA 44 AMP	MOTOR FLA 44 AMP	SLOW SPEED TORQ 1 MIN
STARTER FLC 44 AMP	SOFT START CURVE 1 (STANDARD)	SOFT START CURVE 1 (STANDARD)	SOFT START CURVE 1 (STANDARD)	SOFT START CURVE 1 (STANDARD)	MAX SLOW TIME 30 SEC
CONNECTION TYPE LINE	PULSE TYPE PULSE DISABLE	PULSE TYPE PULSE DISABLE	PULSE TYPE PULSE DISABLE	PULSE TYPE PULSE DISABLE	SAVING ADJUST NO
RATED LINE VOLT 400 VOLT	PULSE VOLTAGE 50 % RATED VOLT	PULSE VOLTAGE 50 % RATED VOLT	PULSE VOLTAGE 50 % RATED VOLT	PULSE VOLTAGE 50 % RATED VOLT	EXTEND SETTING DISABLE
UNDER VOLTAGE 75% RATED VOLT	PULSE CURRENT 0 % FLA	PULSE CURRENT 0 % FLA	PULSE CURRENT 0 % FLA	PULSE CURRENT 0 % FLA	3 OR 2 PHASE 3 PHASE START
OVER VOLTAGE 110% RATED VOLT	PULSE RISE TIME 0.1 SEC	PULSE RISE TIME 0.1 SEC	PULSE RISE TIME 0.1 SEC	PULSE RISE TIME 0.1 SEC	
PHASE SEQUENCE IGNORE	PULSE CONST TIME 0.0 SEC	PULSE CONST TIME 0.0 SEC	PULSE CONST TIME 0.0 SEC	PULSE CONST TIME 0.0 SEC	
O/C - SHEAR PIN 400% FLA	PULSE FALL TIME 0.1 SEC	PULSE FALL TIME 0.1 SEC	PULSE FALL TIME 0.1 SEC	PULSE FALL TIME 0.1 SEC	
UNDER CURRENT 20 % FLA	INITIAL VOLTAGE 28 % RATED VOLT	INITIAL VOLTAGE 28 % RATED VOLT	INITIAL VOLTAGE 28 % RATED VOLT	INITIAL VOLTAGE 28 % RATED VOLT	
OVERLOAD CLASS IEC CLASS: 10	INITIAL CURRENT 0 % FLA	INITIAL CURRENT 0 % FLA	INITIAL CURRENT 0 % FLA	INITIAL CURRENT 0 % FLA	
OVERLOAD PROTECT ENABLE ALWAYS	CURRENT LIMIT 400 % FLA	CURRENT LIMIT 400 % FLA	CURRENT LIMIT 400 % FLA	CURRENT LIMIT 400 % FLA	
O/C CURVE TYPE IEC CURVE: C1	ACCELERATE TIME 10 SEC	ACCELERATE TIME 10 SEC	ACCELERATE TIME 10 SEC	ACCELERATE TIME 10 SEC	
O/C IEC TD 0.05	MAX START TIME 30 SEC	MAX START TIME 30 SEC	MAX START TIME 30 SEC	MAX START TIME 30 SEC	
O/C US TD 0.50	SOFT STOP CURVE 1 (STANDARD)	SOFT STOP CURVE 1 (STANDARD)	SOFT STOP CURVE 1 (STANDARD)	SOFT STOP CURVE 1 (STANDARD)	
O/C PICKUP CURR. 100 % FLA	DECELERATE TIME 30 SEC	DECELERATE TIME 30 SEC	DECELERATE TIME 30 SEC	DECELERATE TIME 30 SEC	
O/C PROTECT DISABLE	STOP FINAL TORQ 0 (MIN)	STOP FINAL TORQ 0 (MIN)	STOP FINAL TORQ 0 (MIN)	STOP FINAL TORQ 0 (MIN)	
MOTOR UNBALANCE 20 % FLA					
GROUND FAULT 20 % FLA					
NUMBER OF STARTS 10					
START PERIOD 30 MINUTE					

² Parameters that are available in Basic mode are in clear cells. DECELERATE TIME
30 SEC

Parameters in Professional and Expert mode, but not in Basic mode are in gray cells. DECELERATE TIME
30 SEC

Parameters that are available in Expert mode only are in gray cells and highlighted. DECELERATE TIME
30 SEC

³ Basic mode only has one Start/Stop Motor menu –

START/STOP ADJ.
- *** -

. Professional has two and Expert has four –

START/STOP 1ST ADJUST	START/STOP 2ND ADJUST	START/STOP 3RD ADJUST	START/STOP 4TH ADJUST
--------------------------	--------------------------	--------------------------	--------------------------

⁴ START/STOP 3rd MOTOR appears in Expert mode only.

⁵ START/STOP 4th MOTOR appears in Expert mode only.

MAIN PARAMETERS - **** -	START/STOP ADJ. 1ST ADJUST ³	START/STOP 2ND ADJUST	START/STOP 3RD ADJUST ⁴	START/STOP 4TH ADJUST ⁵	SPECIAL FEATURES - **** -
START INHIBIT 15 MINUTE					
DISPLAY MODE BASIC					
PARAMETERS LOCK NOT LOCKED					

FAULT PARAMETERS ⁶ - **** -	AUTORESET PARAMS ⁷ - **** -	I/O PROGRAMMING - **** -	COMM OPTION ⁸ - MODBUS -	COMM OPTION ⁸ - PROFIBUS -	COMM OPTION ⁸ - DEVICE NET-
Display and default values	Display and default values	Display and default values	Display and default values	Display and default values	Display and default values
HS OVR TMP TRIP	GLOBAL AUTORESET DISABLE ALL	IN1 PROGRAMMING STOP	BAUD RATE 115200 BPS		
SHORT CIRC TRIP	HS OVR TMP A.RESET DISABLE	IN1 STATE MAINTAIN OPEN	STOP BIT 1.0 BITS		
OVERLOAD TRIP	SHORT CIR A.RESET DISABLE	IN1 MIN ACTIVE 0.1 SEC	PARITY CHECK NONE		
UNDER CURR TRIP	OVERLOAD A.RESET DISABLE	IN1 MIN INACTIVE 0.1 SEC	SERIAL LINK NO. 1	PROFI.NETWORK ID 126	D.NET.NETWORK ID 126
UNDER VOLT TRIP	UNDER CURR A.RESET DISABLE	IN2 PROGRAMMING SOFT STOP	COM CHANGE PARAM	COM CHANGE PARAM	COM CHANGE PARAM
OVER VOLT TRIP	UNDER VOLT A.RESET DISABLE	IN2 STATE MAINTAIN OPEN	CMD VIA COMM NO	CMD VIA COMM NO	CMD VIA COMM NO
PHASE LOSS TRIP	OVER VOLT A.RESET DISABLE	IN2 MIN ACTIVE 0.1 SEC	CMD VALID FOR 1.0 SEC	CMD VALID FOR 1.0 SEC	CMD VALID FOR 1.0 SEC
PHASE SEQ TRIP	PHASE LOSS A.RESET DISABLE	IN2 MIN INACTIVE 0.1 SEC	RESET CMD VALID NO	RESET CMD VALID NO	RESET CMD VALID NO
SHORTED SCR TRIP	PHASE SEQ A.RESET DISABLE	IN3 PROGRAMMING START	COMM TIMEOUT 10.0SEC	COMM TIMEOUT 10.0SEC	COMM TIMEOUT 10.0SEC
LNG STRT TM TRIP	SHORT SCR A.RESET DISABLE	IN3 STATE MAINTAIN CLOSE	UPD COMM STEPS 1ST ACK THEN UPD	UPD COMM STEPS 1ST ACK THEN UPD	UPD COMM STEPS 1ST ACK THEN UPD
SLOW SPD TM TRIP	LNG STRT TM A.RESET DISABLE	IN3 MIN ACTIVE 0.1 SEC	HW VERSION REVISION-1.00	HW VERSION REVISION-1.00	HW VERSION REVISION-1.00
COMM T/O TRIP	SLW SPD TM A.RESET DISABLE	IN3 MIN INACTIVE 0.1 SEC			
EXT FAULT TRIP	COMM T/O A.RESET DISABLE	INPUT POLICY VIA PRIORITY			
WRNG PARAMS TRIP	EXT FAULT A.RESET DISABLE	INPUT PRIORITY IN1, IN2, IN3, COM			
COMM FAILED TRIP	WRNG PARAMS A.RESET DISABLE	RLY1 ACTION FAULT			
TOO MANY TRIP	COMM FAILED A.RESET DISABLE	RLY1 ON STATE ON=NO / OFF=NC			
MTOR INSUL TRIP	TOO MANY A.RESET DISABLE	RLY1 ON DELAY 0.0 SEC			
M OVR TMP TRIP	MTOR INSUL A.RESET DISABLE	RLY1 OFF DELAY 0.0 SEC			
WRONG FREQ TRIP	M OVR TMP A.RESET DISABLE	RLY2 ACTION END OF ACC			
M.UNBALANCE TRIP	WRONG FREQ A.RESET DISABLE	RLY2 ON STATE ON=NO / OFF=NC			
GND FAULT TRIP	NO VOLTAGE A.RESET DISABLE	RLY2 ON DELAY 0.0 SEC			
NO CURRENT TRIP	M.UNBALANCE A.RESET DISABLE	RLY2 OFF DELAY 0.0 SEC			
NO CTR PWR TRIP	GND FAULT A.RESET DISABLE				
OVER CURR TRIP	NO CURRENT A.RESET DISABLE				
SHEAR PIN TRIP	NO CTR PWR A.RESET DISABLE				

⁶ There are three separate parameters for each FAULT PARAMETERS listing: FLT, DLY and AFTR.

⁷ There are 7 separate parameters for each AUTORESET PARAMS listing: MODE, TRY, 1ST, DLY, SLVD, TRY0, RNEN.

⁸ This menu only appears if the relevant communication option card was added.

FAULT PARAMETERS ⁶ _ **** _	AUTORESET PARAMS ⁷ _ **** _	I/O PROGRAMMING _ **** _	COMM OPTION ⁸ - MODBUS -	COMM OPTION ⁸ - PROFIBUS -	COMM OPTION ⁸ - DEVICE NET-
WRONG VZC IGNORE	OVER CURR A.RESET DISABLE				
WELDED CON. TRIP	SHEAR PIN A.RESET DISABLE				
BYPASS FAULT ⁹ TRIP	WRONG VZC A.RESET DISABLE				
NO CALIBRATION TRIP	WELDED CON. A.RESET DISABLE				

ANALOG OPTION ¹⁰ THERMISTOR INPUT	ANALOG OPTION ¹¹ TEMP. RELAY-3IN	GLOBAL PARAMETER _ **** _	STATISTICAL DATA ¹² _ **** _	TEST / MAINTENANCE _ **** _
Display and default values	Display and default values	Display and default values	Display and default values	Display and default values
OUTPUT OPTION Vrms OUTPUT	MAX TEMPERATURE 120 C	SET TIME 00:00:00	TOTAL ENERGY 0 KW/H	VERSION NUMBER:
MANUAL SETTING 50%		SET DATE 01/01/2014	LAST STRT PERIOD 0SEC	VERSION DATE:
CURRENT RANGE 4 - 20 mA		DEFAULT DATA V/I/POWER FACTOR	LAST STRT MAX I 0 % FLA	VERSION CRC16:
THERMISTOR TYPE PTC		LCD CONTRAST [*****]	TOTAL RUN TIME 0 HOURS	CNTRL HW VERSION
LIMIT RESISTANCE 30000 OHM		LCD INTENSITY [*****]	TOTAL # OF STRTS 0	POWER HW VERSION
			LAST TRIP NO FAULT	GISALBA VERSION ⁹
			TRIP CURRENT 0 % FLA	GISALBA TYPE ⁹
			TOTAL # OF TRIPS 0	EEPROM VERSION
			PREVIOUS TRIP -1 NO FAULT	
			PREVIOUS TRIP -2 NO FAULT	
			PREVIOUS TRIP -3 NO FAULT	
			PREVIOUS TRIP -4 NO FAULT	
			PREVIOUS TRIP -5 NO FAULT	
			PREVIOUS TRIP -6 NO FAULT	
			PREVIOUS TRIP -7 NO FAULT	
			PREVIOUS TRIP -8 NO FAULT	
			PREVIOUS TRIP -9 NO FAULT	
			PREVIOUS TRIP -10 NO FAULT	
			RESET STATISTICA ENTER TO RESET	

⁹ This menu only appears with size D and above.

¹⁰ This menu only appears if a Thermistor Input and Analog Output option card was added.

¹¹ This menu only appears if a 3XRTD Thermal Sensor option card was added.

¹² Parameter viewed only when used.

6.6.1 Main Parameters – page 1

MAIN PARAMETERS - **** -			
Display and default values	Range	Description	Remarks
SET LANGUAGE: ENGLISH	ENGLISH GERMAN SPANISH FRENCH RUSSIAN (Optional)	Sets Starter's language	
STARTER FLC 44 AMP	N/A	Displays the FLC (Full load current)	This parameter is not configurable.
CONNECTION TYPE LINE	LINE INSIDE DELTA	Sets Starter's connection type.	Factory preset – features and functions when “INSIDE DELTA” mode is configured: No Pulse Start. No Curve selection (CURVE 0!). No slow speed. No phase sequence “off” mode. Refer to section Error! Reference source not found. on page Error! Bookmark not defined. for further information
RATED LINE VOLT 400 VOLT	208-600V 190-600V	Sets rated LINE VOLTAGE.	The maximum rated voltage depends on the rated voltage of the iStart.
UNDER VOLTAGE 75% RATED VOLT	50-90%	Trips the iStart when line voltage drops below the % defined.	
OVER VOLTAGE 110% RATED VOLT	109-125%	Trips the iStart when line voltage increases above the % defined.	
PHASE SEQUENCE IGNORE	IGNORE POSITIVE NEGATIVE		Sets the PHASE SEQUENCE of the soft starter. Allows to start the motor in POSITIVE sequence of the mains OR in the NEGATIVE sequence of the mains or, when set to IGNORE, in both sequences.

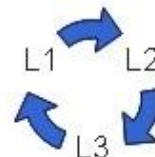

Positive sequence

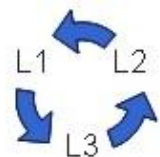

Negative sequence

MAIN PARAMETERS - **** -															
Display and default values	Range	Description	Remarks												
O/C SHEAR PIN 400% FLA	100%-400% Note: The range of the OVER-CURRENT SHEAR PIN can be extended to 850% by using the EXTEND SETTING.	Sets OVER-CURRENT SHEAR PIN protection.	Operational during run time only. Note: This protection is not intended to replace fast acting fusser to protect from short current!												
UNDER CURRENT 20 % FLA	0%-90%	Sets minimum allowed current.	Operational during run time only. If the current drops to this level a trip will occur.												
OVERLOAD CLASS IEC CLASS: 10	IEC CLASS 5 IEC CLASS 10 IEC CLASS 20 IEC CLASS 30 NEMA CLASS 5 NEMA CLASS 10 NEMA CLASS 20 NEMA CLASS 30	Sets OVERLOAD curve.	Sets OVERLOAD CLASS characteristics Sets OVERLOAD PROTECT functionality. The iStart allows motor protection according to IEC class 5 or 10 or according to NEMA class 10, 20 or 30. Tripping curves are shown in section 6.6.1.2 on page 56. The OVERLOAD protection incorporates a THERMAL CAPACITY register that calculates heating minus dissipation of the motor. The iStart trips when the register fills up. (THERMAL CAPACITY=100%) The time constant, in seconds, for cool down after overload trip is: <table border="1" data-bbox="922 1182 1398 1321"> <thead> <tr> <th>Class</th> <th>10</th> <th>20</th> <th>30</th> </tr> </thead> <tbody> <tr> <td>IEC</td> <td>320</td> <td>640</td> <td>-</td> </tr> <tr> <td>NEMA</td> <td>280</td> <td>560</td> <td>840</td> </tr> </tbody> </table>	Class	10	20	30	IEC	320	640	-	NEMA	280	560	840
Class	10	20	30												
IEC	320	640	-												
NEMA	280	560	840												
OVERLOAD PROTECT ENABLE ALWAYS	DISABLE/ ENABLE WHILE RUN/ ENABLE ALWAYS		The overload protection can be set to protect the motor as set in the OVERLOAD PROTECT parameter: ENABLE ALWAYS – motor is protected at all times. ENABLE WHILE RUN – motor is protected only when in Run. DISABLE – motor is not overload protected by the soft starter. Note: In order to restart after OVERLOAD trip, the thermal register should be 50% or less.												
O/C CURVE TYPE IEC CURVE: C1	IEC CURVE: C1 IEC CURVE: C2 IEC CURVE: C3 IEC CURVE: C4 IEC CURVE: C5 U.S. CURVE: U1 U.S. CURVE: U2 U.S. CURVE: U3 U.S. CURVE: U4 U.S. CURVE: U5	Curve types that are defined in IEEE standard 37.112-1996 IEEE standard inverse-time characteristic equations for over current relays	For details, refer to section 6.6.1.1 Tripping Curves of the Integrated Overcurrent Protection on page 50.												

MAIN PARAMETERS _ **** _			
Display and default values	Range	Description	Remarks
O/C IEC TD 0.05	0.05 0.10 - 1.00 (increments of 0.10)	Sets the time dial	Relevant only for IEC curves. Lower time dial results in over current protection taking effect sooner.
O/C US TD 0.50	0.50 1.00 2.00 3.00 4.00 5.00 6.00 8.00 10.00 12.00 15.00	Sets the time dial	Relevant only for U.S. curves. Lower time dial results in over current protection taking effect sooner.
O/C PICKUP CURR. 100 % FLA	100 – 600 (increments of 50)	Sets the sensitivity of the over current protection	Lower pickup current results in over current protection taking effect sooner. See 6.6.1.1 for more details.
O/C PROTECT DISABLE	DISABLE/ ENABLE WHILE RUN/ ENABLE ALWAYS		The over current protection can be set to protect the motor as set in the O/C PROTECT parameter: ENABLE ALWAYS – motor is protected at all times. ENABLE WHILE RUN – motor is protected only when in Run. DISABLE – motor is not over current protected by the soft starter.
MOTOR UNBALANCE 20 % FLA	10 - 100 % of Motor FLA. Increments of 1%	Sets the motor unbalance protection	Current unbalance is the ratio between the highest and lowest current of the motor. Unbalance = I_2 / I_1 (Limited to: Unbalance <= 100%) Where: I_2 = highest current, I_1 = lowest current .
GROUND FAULT 20 % FLA	1 – 60% of FLA. Increments of 1%	Sets the allowed ground fault level	iStart calculates the sum of I_1 , I_2 and I_3 . A trip occurs when the ground fault exceeds the GROUND FAULT LEVEL
NUMBER OF STARTS 10	Off, 1-10	These three parameters work together to set the number of starts allowed during a defined time period	If NUMBER OF STARTS is off, then there is no limit. When a NUMBER OF STARTS is set, then START PERIOD sets the length of time during which you cannot exceed the NUMBER OF STARTS. If you reach the NUMBER OF STARTS during the START PERIOD, iStart waits the START INHIBIT time until it allows the next start.
START PERIOD 30 MINUTE	1-60 minutes		
START INHIBIT 15 MINUTE	1-60 minutes		
DISPLAY MODE BASIC	BASIC PROFESSIONAL EXPERT	Sets the display mode	EXPERT is visible only while in Professional or Expert display mode To go from Basic to Expert, you must first change to Professional mode.
			<div style="background-color: yellow; display: inline-block; padding: 2px;">WARNING!</div> <div style="display: inline-block; padding: 2px;">Operator's Responsibility!</div> <div style="display: inline-block; padding: 2px; margin-left: 10px;">Expert mode allows settings that can damage the starter and the motor.</div>

MAIN PARAMETERS _ **** _			
Display and default values	Range	Description	Remarks
PARAMETERS LOCK NOT LOCKED	LOCKED NOT LOCKED	Locks or unlocks parameter modifications.	The software lock prevents undesired parameter modification. When locked, the LCD displays the current value of all other parameters, but does not allow you to change them.

6.6.1.1 Tripping Curves of the Integrated Overcurrent Protection

The iStart allows motor protection according to U.S. class U1, U2, U3, U4 or U5 (TD = 0.50 – 15.00) or according to IEC class C1, C2, C3, C4 or C5 (TD = 0.05 – 1.00).

The horizontal axis represent ratio of [starter Current / pickup current parameter]:

e.g. the current of starter is now 250% of FLA , and O/C PICKUP CURR. Parameter is “100% FLA” – so the multiple of pickup current will be : $250\%FLA / 100\%FLA = 2.5$.

The vertical axis represent the time in seconds.

Over current example:

We will choose the settings to be:

- O/C CURVE TYPE → IEC CURVE: U1
- O/C IEC TD → Not relevant to U.S. curves.
- O/C US TD → 8.00
- O/C PICKUP CURR. → 150 % FLA
- O/C PROTECT → ENABLE ALWAYS

Then if the starter’s current is 450% of FLA, then the multiple of pickup current will be : $450\%FLA / 150\%FLA = 3$.

According to the “U1 Curves” chart below – with Time Dial of 8.00 and multiple of pickup of 3 – the O/C trip will occur after 4 seconds.

U.S. Class OVERCURRENT curves:

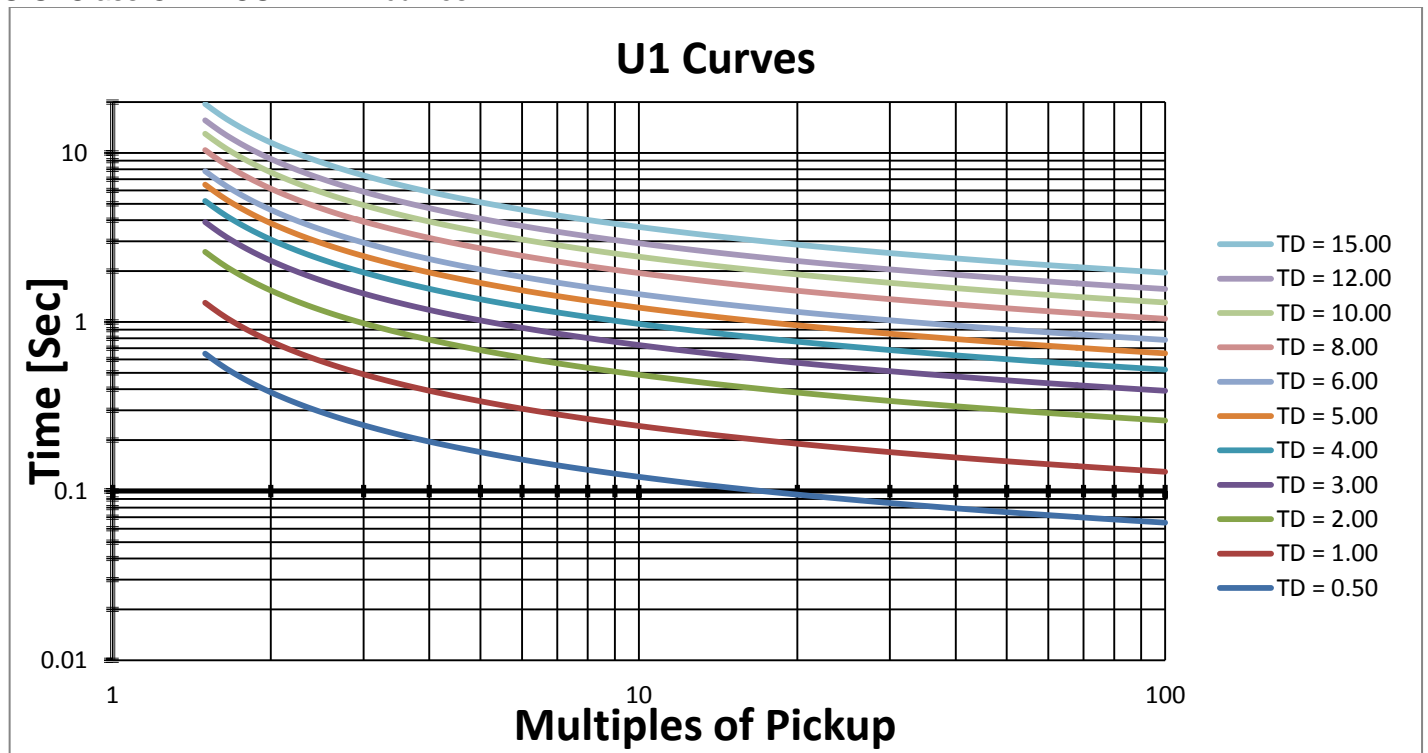

Figure 10: U.S. Class OVERCURRENT curves – U1 curves

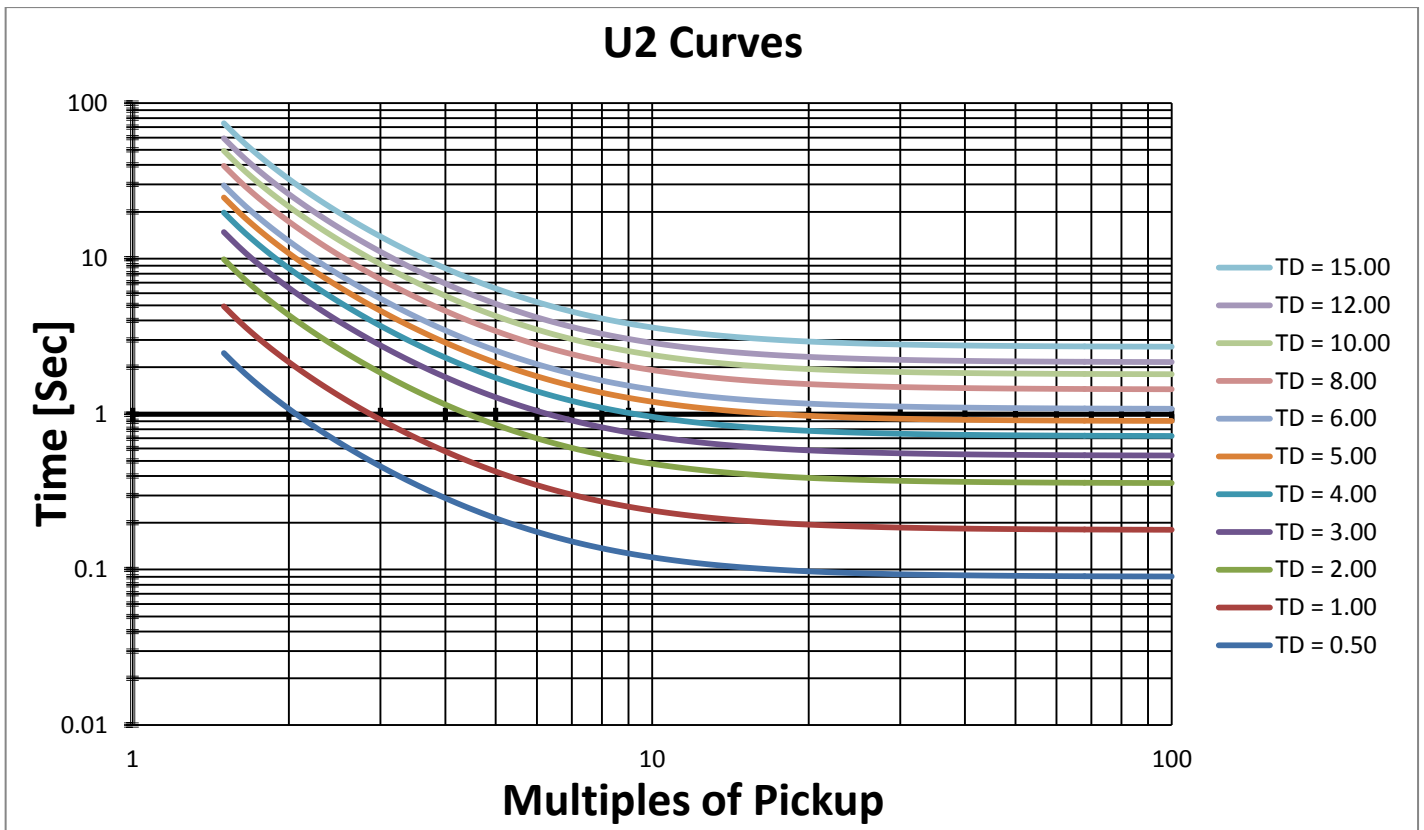

Figure 11: U.S. Class OVERCURRENT curves – U2 curves

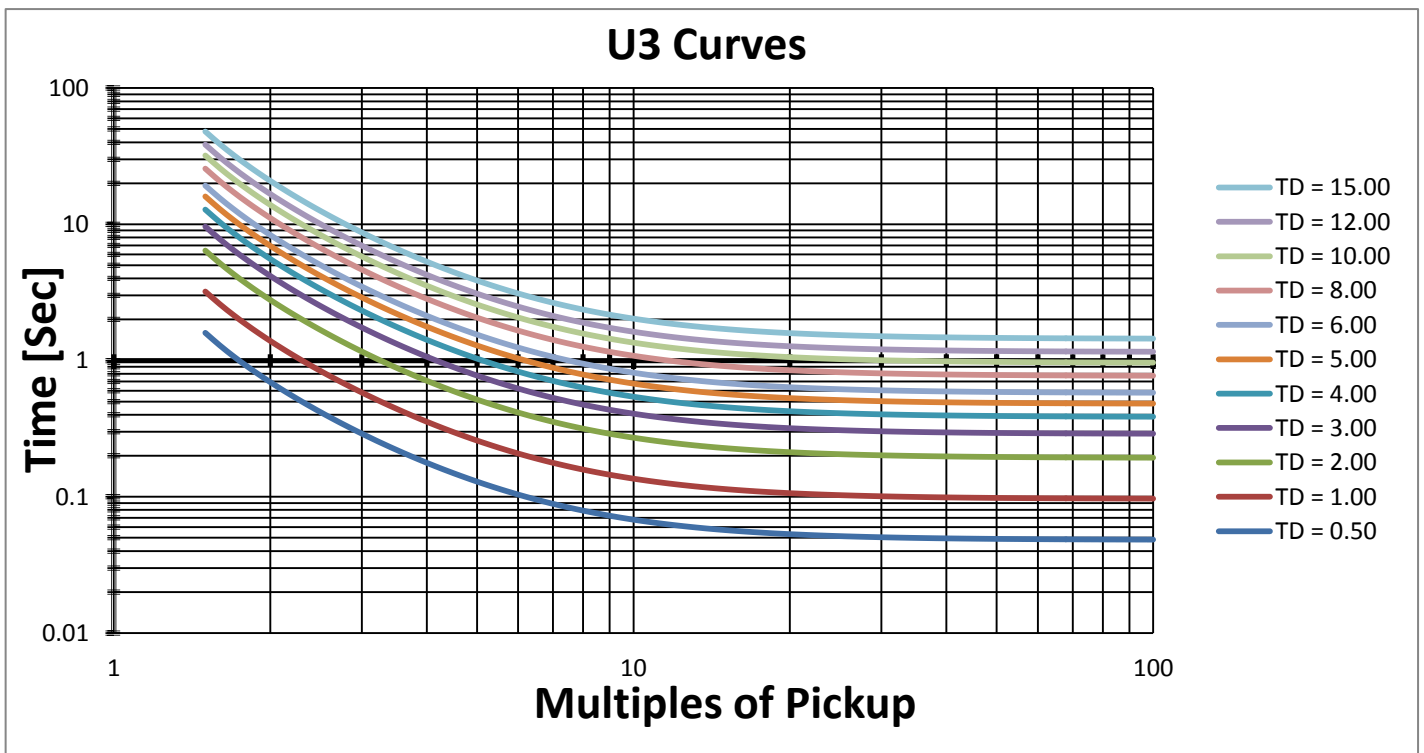

Figure 12: U.S. Class OVERCURRENT curves – U3 curves

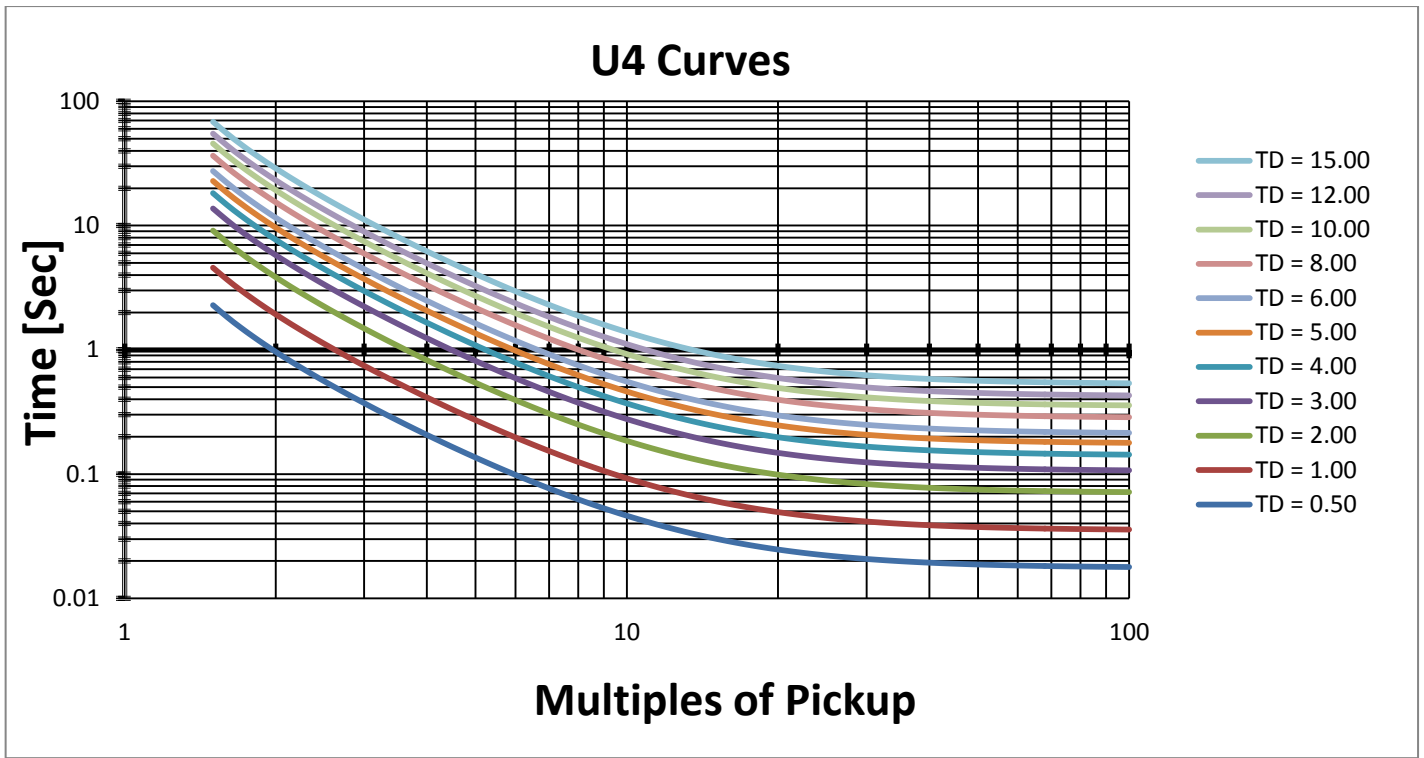

Figure 13: U.S. Class OVERCURRENT curves – U4 curves

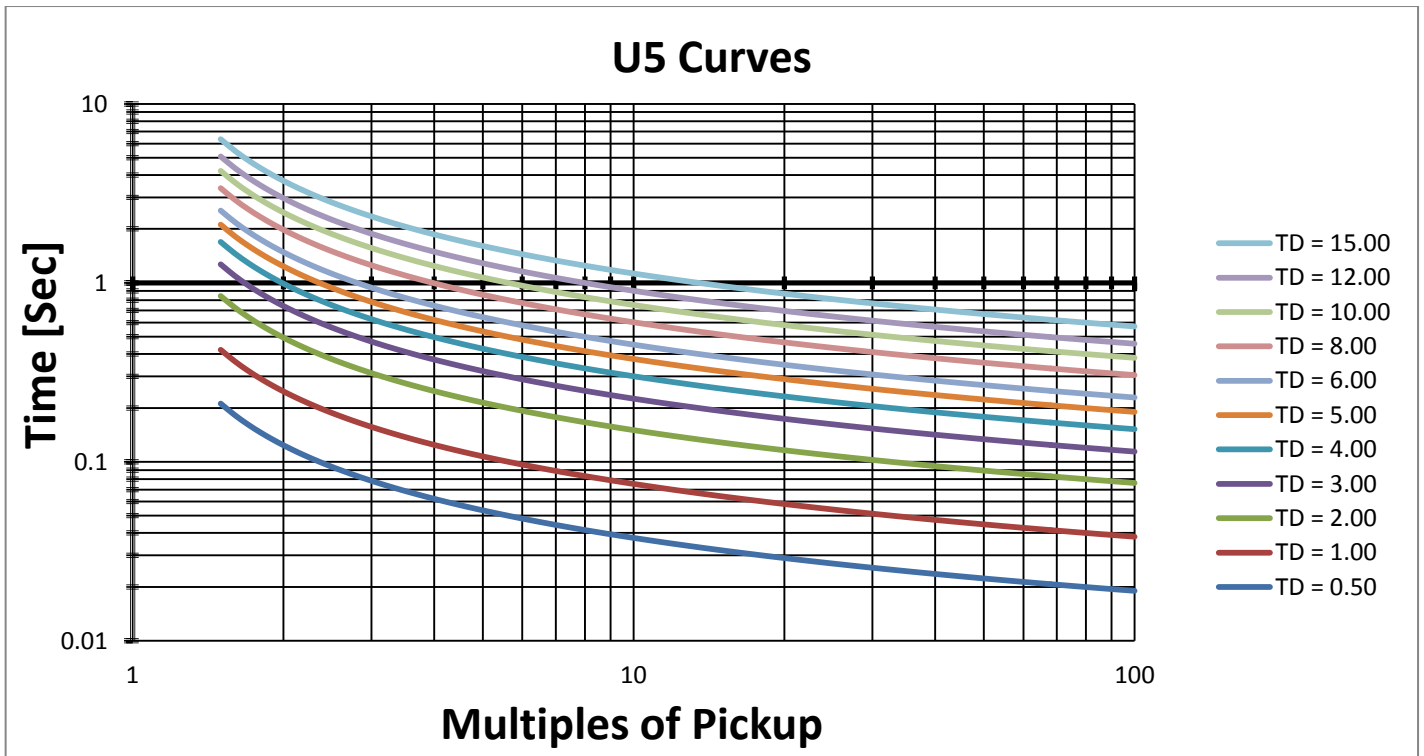

Figure 14: U.S. Class OVERCURRENT curves – U5 curves

IEC Class OVERCURRENT curves:

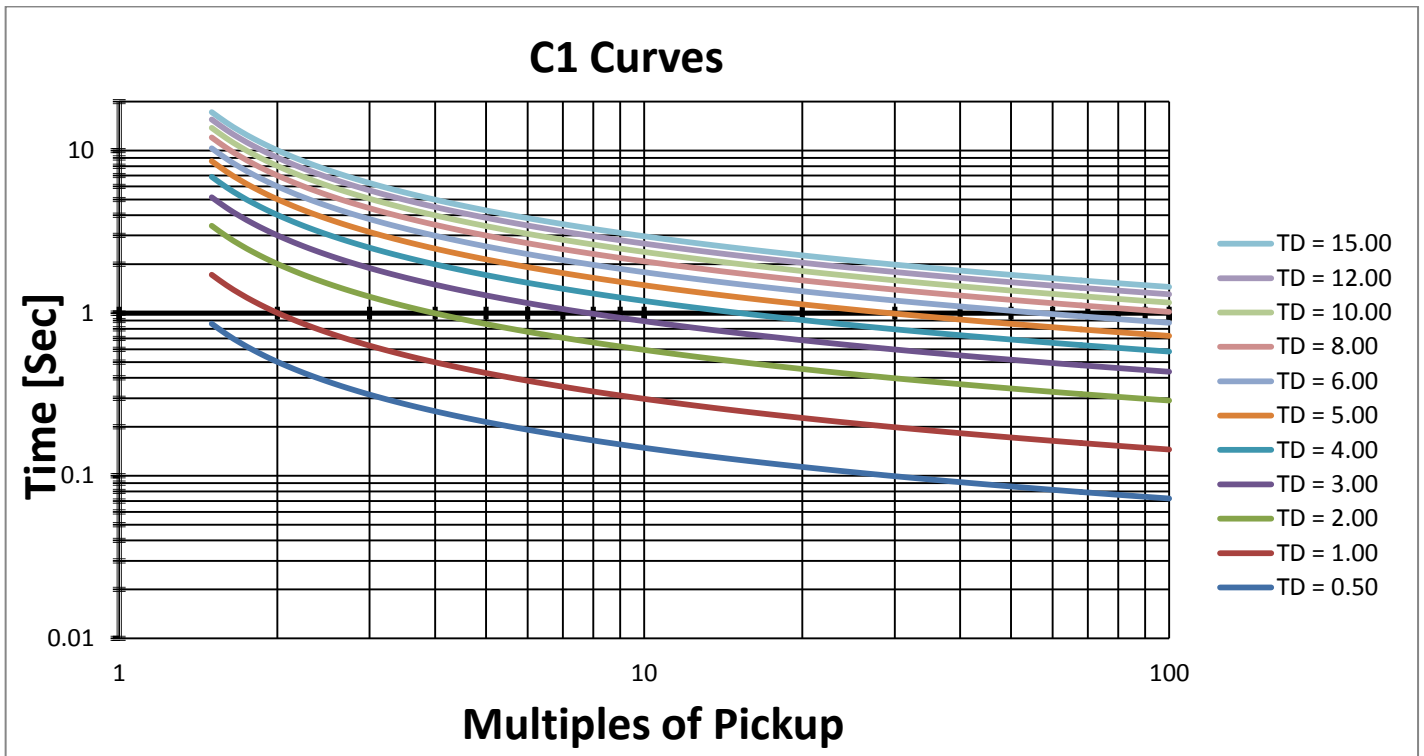

Figure 15: IEC Class OVERCURRENT curves – C1 curves

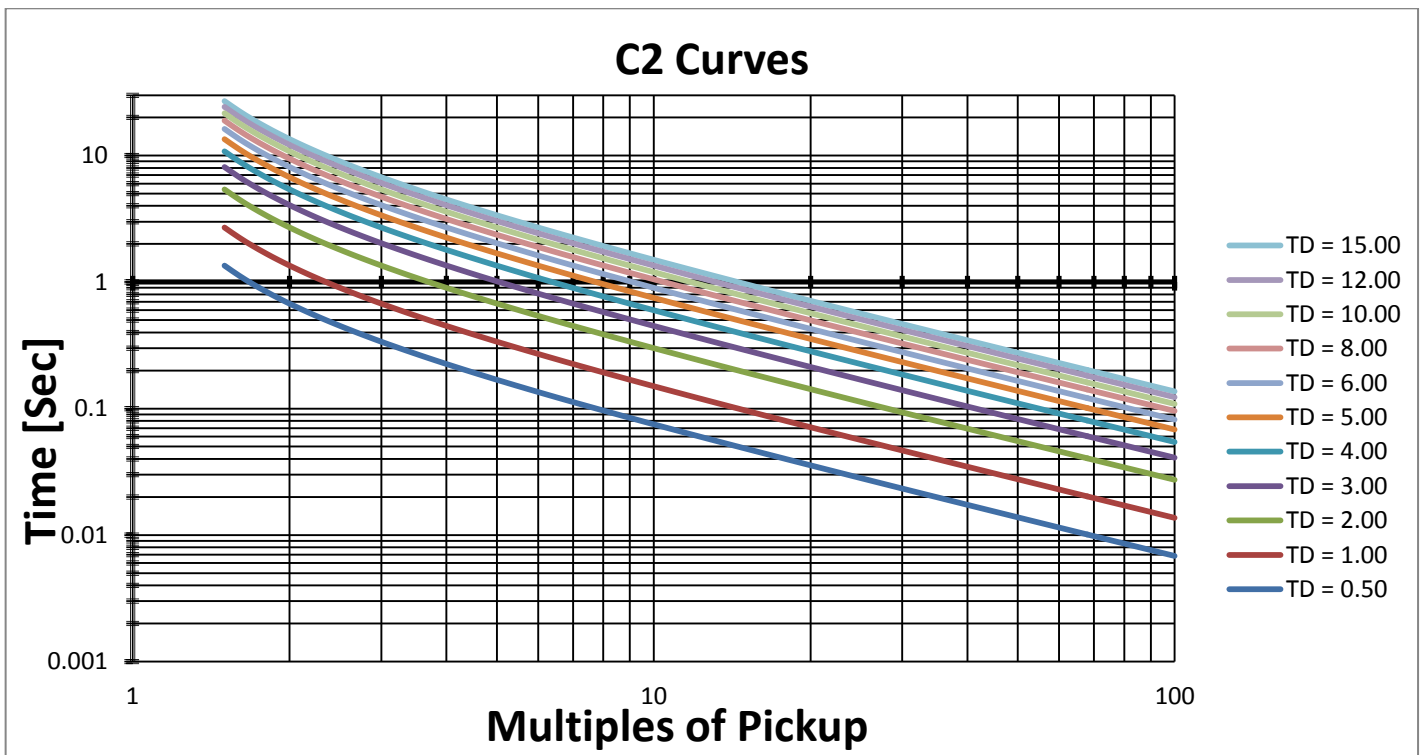

Figure 16: IEC Class OVERCURRENT curves – C2 curves

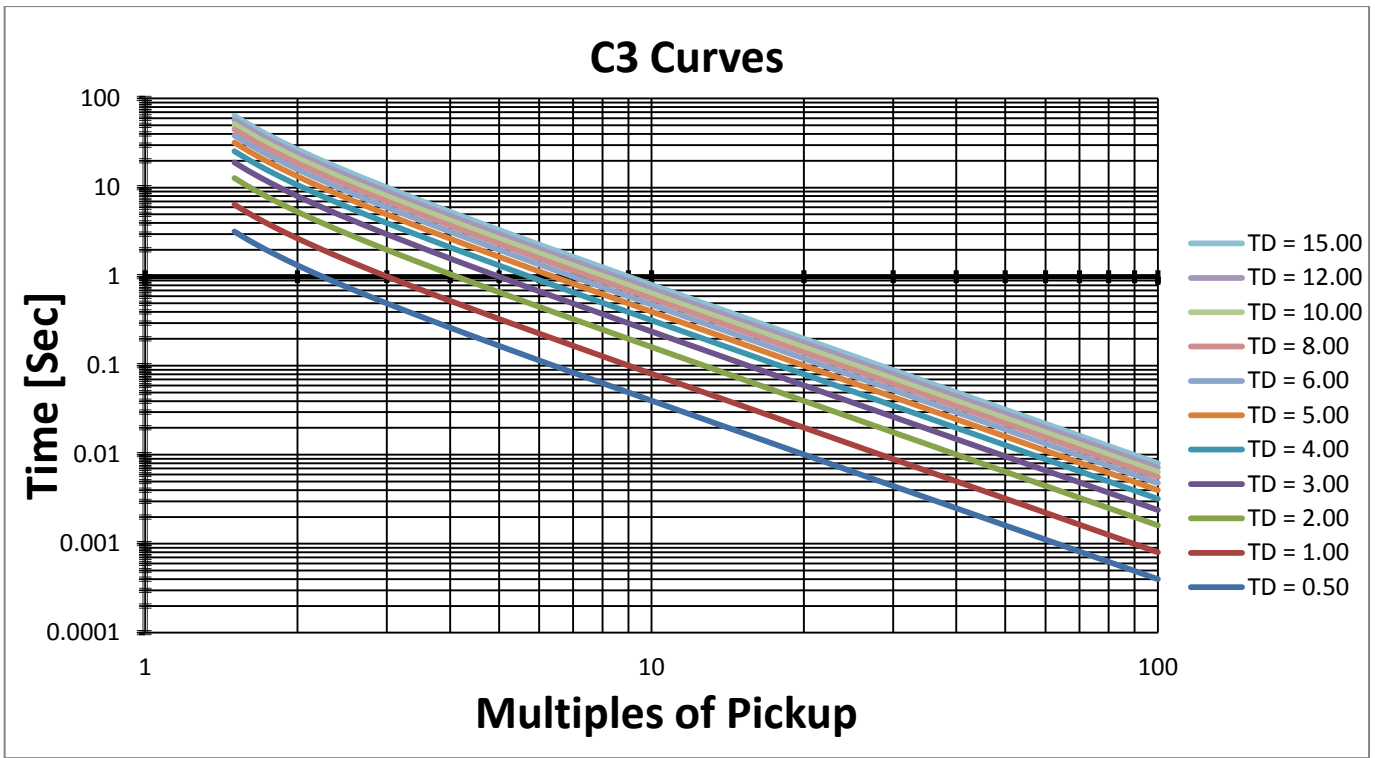

Figure 17: IEC Class OVERCURRENT curves – C3 curves

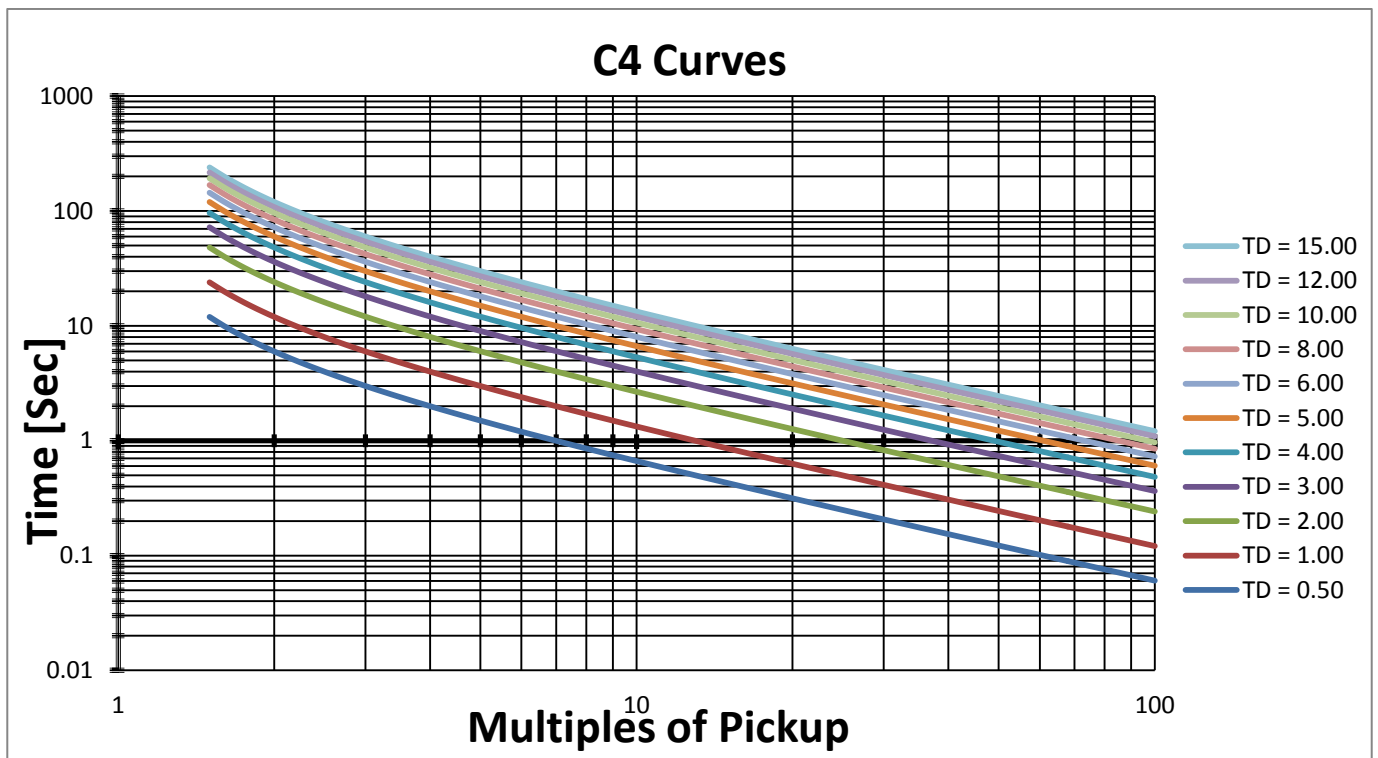

Figure 18: IEC Class OVERCURRENT curves – C4 curves

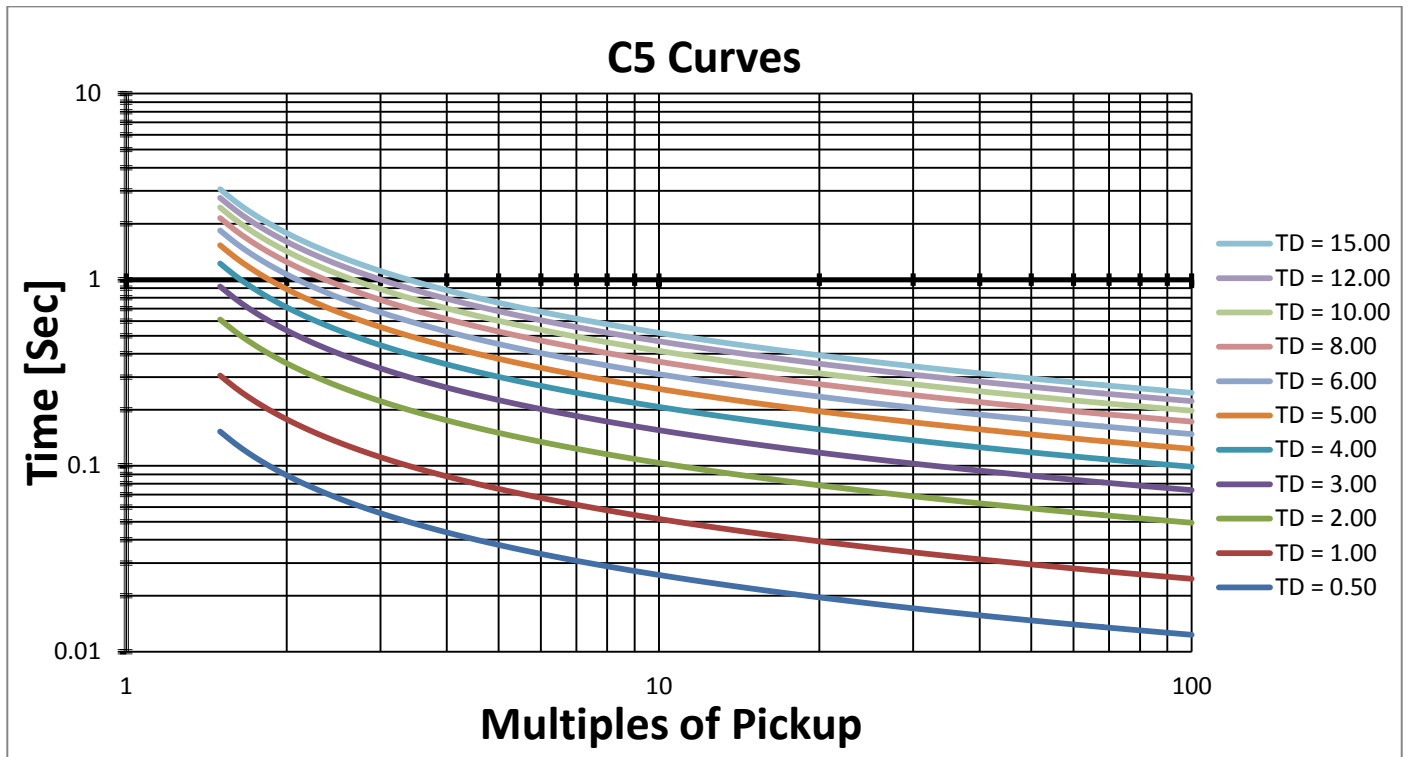
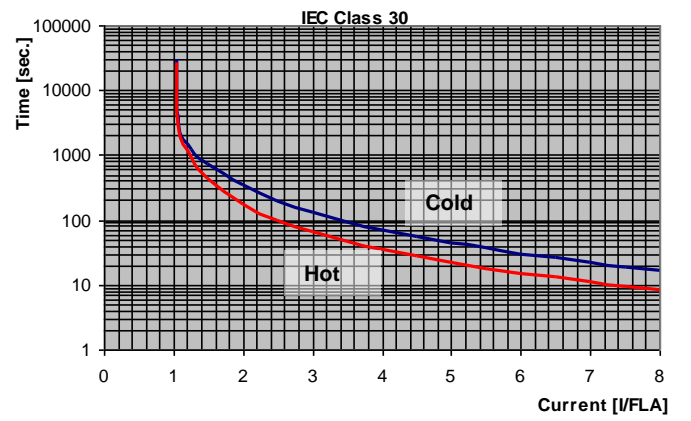
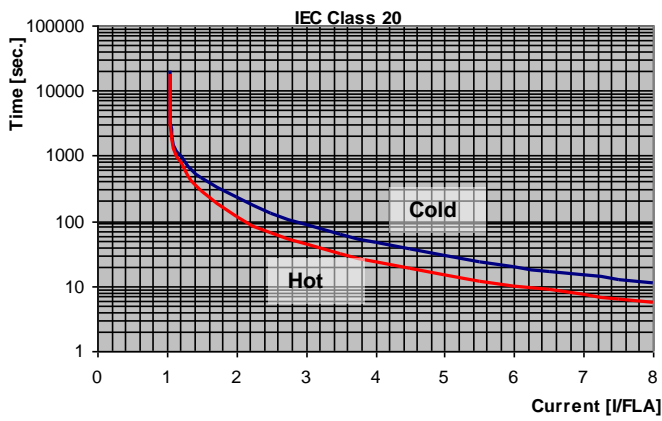
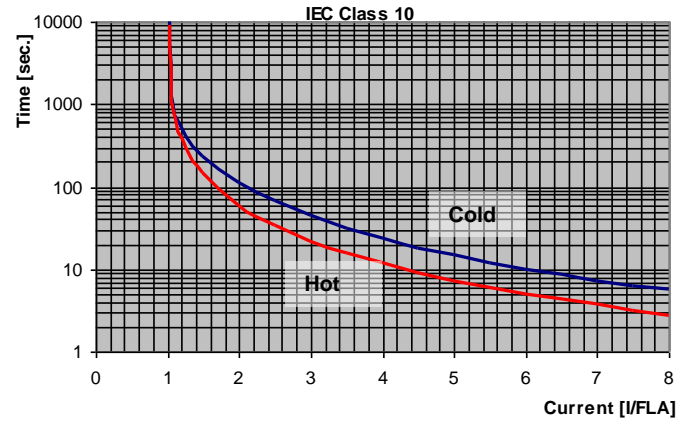
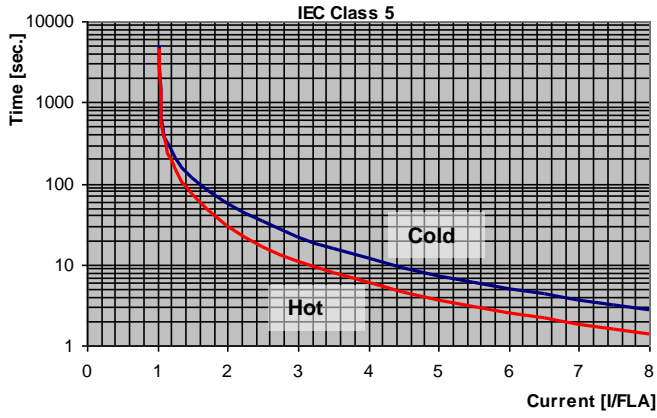

Figure 19: IEC Class OVERCURRENT curves – C5 curves

6.6.1.2 Tripping Curves of the Integrated Overload Protection

The iStart allows motor protection according to IEC class 5, 10, 15, 20, 25 or 30 OR according to NEMA class 5, 10, 15, 20, 25 or 30.

IEC Class OVERLOAD curves



NEMA Class OVERLOAD curves

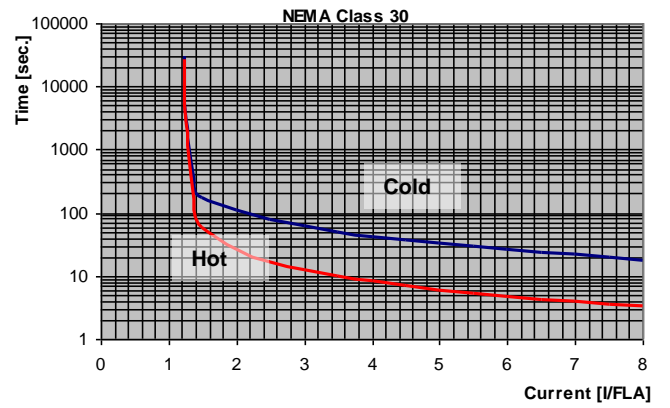
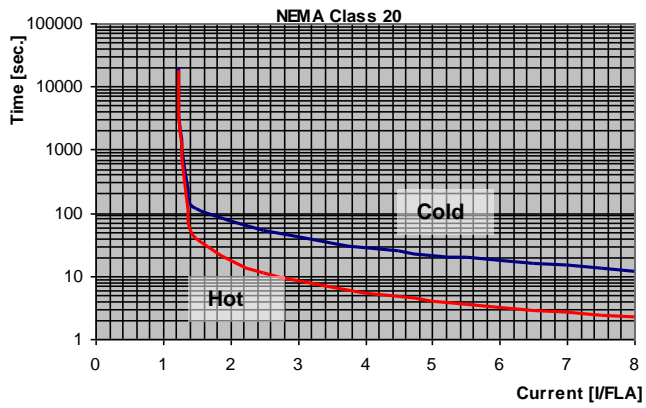
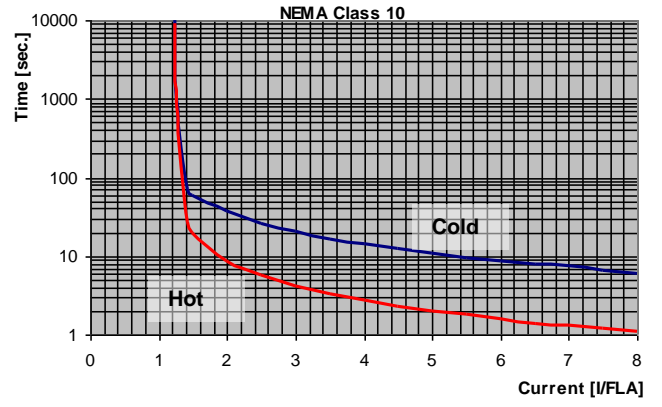
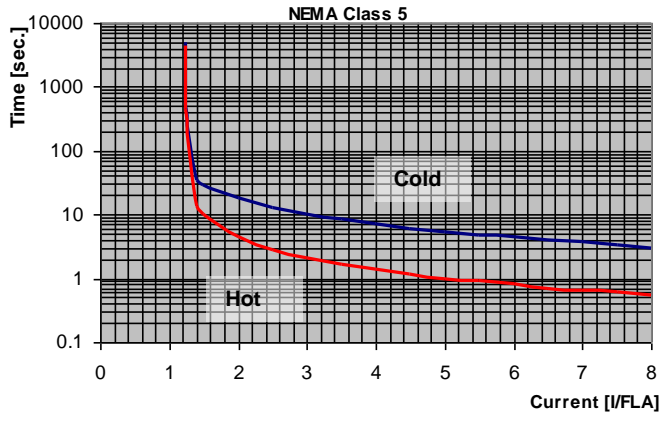

6.6.2 Start/Stop adjust¹³ – page 2 of Basic (pages 2-3 of Professional, pages 2-5 of Expert)

START/STOP ADJUST			
Display and default values	Range	Description	Remarks
MOTOR FLA 44 AMP	50%-100% of STARTER FLC	Sets iSTART's FLA (Full Load Ampere).	Should be programmed as shown on the motor's name plate. Note: When the iStart is installed Inside Delta, set MOTOR FLA = <rated motor current>/1.73.
SOFT START CURVE 1 (STANDARD)	9 !! - DOL - !! 5 !! TORQUE !! 4 !! PUMP 3 !! 3 !! PUMP 2 !! 2 !! PUMP 1 !! 1 – STANDARD - 0 !! GENERATOR !!	Sets starter's SOFT START CURVE.	When iStart is connected "Inside-Delta", only CURVE 1 is applied.
PULSE TYPE PULSE DISABLE	PULSE DISABLE VOLTAGE PULSE E. CURRENT PULSE E.	Sets the type of the initial pulse for motor start.	Professional and Expert only. Intended to start high friction loads, requiring high starting torque for a short time. Note: When iStart is connected "Inside-Delta", PULSE START can not be activated.
PULSE VOLT 50% RATED VOLT	50-99% RATED VOLT	Sets the max. volt level.	Professional and Expert only. Relevant only when PULSE TYPE is VOLTAGE PULSE E.
PULSE CURRENT 0% FLA	0-700% FLA	Sets the max. current level.	Professional and Expert only. Relevant only when PULSE TYPE is CURRENT PULSE E.
PULSE RISE TIME 0.1 SEC	0 – 0.5 SEC.	Sets the amount of time for the pulse to reach the PULSE VOLT or PULSE CURRENT level.	Professional and Expert only.
PULSE CONST TIME 0.0 SEC	0 – 1.0 SEC.	Sets the length of time that the pulse will remain at the PULSE VOLT or PULSE CURRENT level.	Professional and Expert only.
PULSE FALL TIME 0.1 SEC	0 – 0.5 SEC.	Sets the amount of time for the pulse to return to its initial voltage or current level.	Professional and Expert only.

¹³ Parameters that are available in Basic mode are in clear cells.

Parameters that are available in Professional and Expert mode, but not in Basic mode are in gray cells.

Parameters that are available in Expert mode only are in gray cells and highlighted.

START/STOP ADJUST			
Display and default values	Range	Description	Remarks
INITIAL VOLTAGE 28 % RATED VOLT	28-45% Note: The range of the INITIAL VOLTAGE can be extended to 25-60% by using the EXTEND SETTING.	Sets the starting voltage of the motor. The motor's torque is directly proportional to the square of the voltage.	This adjustment also determines the inrush current and mechanical shock. A setting that is too high may cause high initial mechanical shock and high inrush current (even if CURRENT LIMIT is set low, because the INITIAL VOLTAGE setting overrides CURRENT LIMIT setting). A setting that is too low may result in prolonged time until the motor begins to turn. In general, this setting should ensure that the motor begins turning immediately after the start signal.
INITIAL CURRENT 0 % FLA	0-400%	Sets the starting current of the motor.	Professional and Expert only.

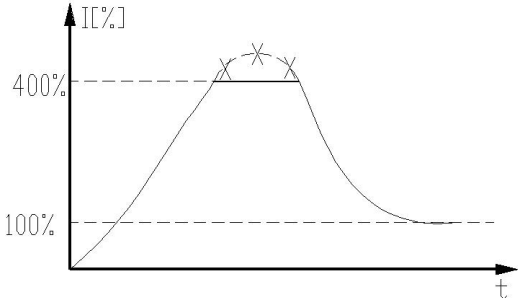
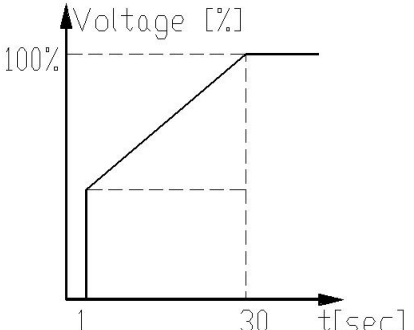
START/STOP ADJUST			
Display and default values	Range	Description	Remarks
<p>CURRENT LIMIT 400 % FLA</p>	<p>100-400%</p> <p>Note: The range of the CURRENT LIMIT can be extended to 70-400% by using the EXTEND SETTING as described in section as described in section 6.6.3.1 on page 65.</p>	<p>Sets motor's highest current during starting.</p>	<p>A high setting that is too will cause greater current to be drawn from mains and faster acceleration. A setting that is too low may prevent the motor from completing the acceleration process and reaching full speed. In general, this setting should be set to a high enough value to prevent stalling.</p> <p>Note: CURRENT LIMIT does not operate during Run and Soft stop.</p>  <p>Figure 20: Current limit</p>
<p>ACCELERATE TIME 10 SEC</p>	<p>1-30sec.</p> <p>Note: Range can be extended to 1-90sec. by using the EXTEND SETTING.</p>	<p>Sets ACCELERATION TIME of the motor.</p>	<p>Determines motor's voltage ramp-up time, from initial to full voltage.</p> <p>It is recommended to set ACCELERATION TIME to the minimum acceptable value (approx. 5 sec).</p>  <p>Figure 21: Accelerate time</p> <p>Notes: Since CURRENT LIMIT overrides ACCELERATE TIME, when CURRENT LIMIT is set low, starting time will be longer than the preset ACCELERATE TIME. When motor reaches full speed before voltage reaches nominal, ACCELERATE TIME setting is overridden, causing voltage to quickly ramp-up to nominal. Using starting curves 2, 3, 4 prevents quick ramp up.</p>

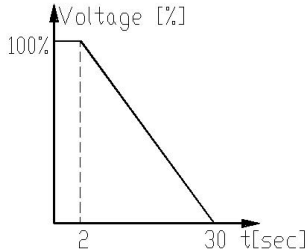
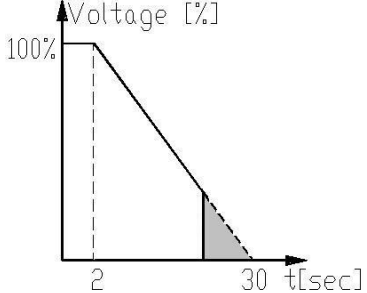
START/STOP ADJUST			
Display and default values	Range	Description	Remarks
MAX START TIME 30 SEC	1-30sec. Note: Range can be extended to 1-250sec.by using the EXTEND SETTING.	Sets MAXIMUM START TIME	The maximum allowable start time, from Start signal to end of acceleration process. If voltage does not reach full voltage/speed during this time (e.g. because of too low CURRENT LIMIT setting), the starter will trip the motor. LCD displays “LONG START TIME” message.
SOFT STOP CURVE 1 (STANDARD)	9 !! - DOL - !! 5 !! TORQUE !! 4 !! PUMP 3 !! 3 !! PUMP 2 !! 2 !! PUMP 1 !! 1 – STANDARD - 0 !! GENERATOR !!	Sets starter’s SOFT STOP CURVE.	Refer to section 6.6.2.2 on page 63
DECELERATE TIME 30 SEC	0 – 30sec. Note: Range can be extended to 90sec. by using the EXTEND SETTING.	Sets DECELERATION TIME of the motor.	Used for controlled deceleration of high friction loads. Determines motor’s voltage ramp down time.  Figure 22: Decelerate time
STOP FINAL TORQUE 0 (MIN)	0(MIN) - 10(MAX)	Sets FINAL TORQUE during Soft Stop.	This option is not available yet, even though the LCD enables its selection. For more information, contact Solcon’s sales department. Expert only. Determines torque towards end of SOFT STOP. If current is still flowing after speed is softly reduced to zero, increase FINAL TORQUE setting.  Figure 23: Stop final torque

6.6.2.1 Soft Start Parameters

The iStart incorporates 5 “Starting Curves”, enabling selection of the suitable torque curve.

Start Curve 0 – Only use curve 0 when a SHORTED SCR fault occurs **and** only after you tested and made sure that the SCRs, motor and motor connections are not faulty.

Start Curve 1 – Standard curve (default). The most stable and suitable curve for the motor, prevents prolonged starting and motor overheating.

Note:

When iStart is connected “Inside-Delta”, only CURVE 1 is applied.

Start curves 2-4 - “Pump Control” - Induction motors produce peak torque of up to 3 times the rated torque towards the end of starting process. In some pump applications, this peak may cause high pressure in the pipes.

Start Curves 2, 3, 4 – During acceleration, before reaching peak torque, the Pump Control Program automatically controls the voltage ramp-up, thereby reducing peak torque.

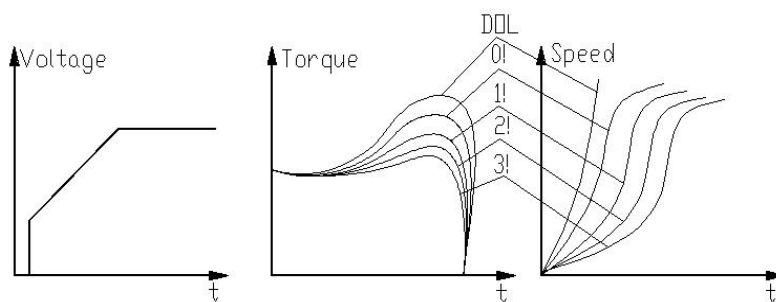

Figure 24: Start curves 2-4

Choice of three pump control acceleration curves: 1!, 2!, 3!, 4!

Start Curve 5 (Torque) – Torque Controlled acceleration, provides a smooth time controlled torque ramp for the motor and the pump.

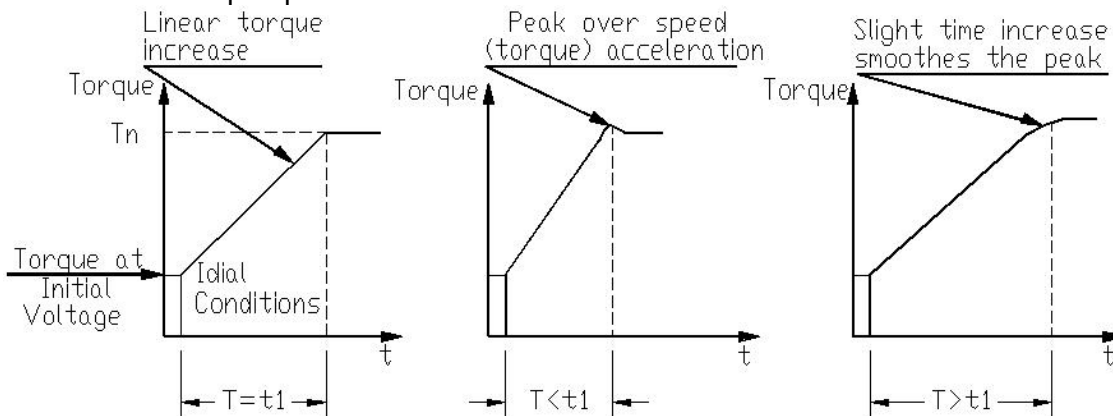

Figure 25: Start curve 5 (torque)

Start Curve 9 (DOL) – Direct Online closes the bypass and connects the motor directly.

Note:

Always start with Start Curve 1. If towards end of acceleration, peak torque is too high (pressure is too high), proceed to Curve 2, 3, 4 or 5.

6.6.2.2 Soft Stop Parameters

The iStart incorporates 5 “Starting Curves”, enabling selection of the suitable torque curve.:

Start Curve 0 – Only use curve 0 when a SHORTED SCR fault occurs **and** only after you tested and made sure that the SCRs, motor and motor connections are not faulty.

Stop Curve 1 – Standard curve (default) – voltage is linearly reduced from nominal to zero. This is the most stable and suitable curve for the motor, preventing prolonged stopping and motor overheating.

Stop Curves 2, 3, 4 Pump Control – In some pump applications, when pumping to a higher level, a considerable part of the torque is constant and does not decrease with speed. During the deceleration process, when voltage is decreasing, motor torque can fall below load torque abruptly (instead of smoothly decreasing speed to zero), thus closing the valve and causing Water Hammer. Curves 2, 3 and 4 are intended to prevent Water Hammer phenomenon. In pump applications, load torque decreases in square relation to the speed, thus correct control of voltage reduction reduces torque adequately to smoothly decelerate to a stop.

Note:

It is recommended that you use Stop Curve 1 for all standard applications (not pumps). To reduce Water Hammer, select STOP CURVE 2, than 3 or 4.

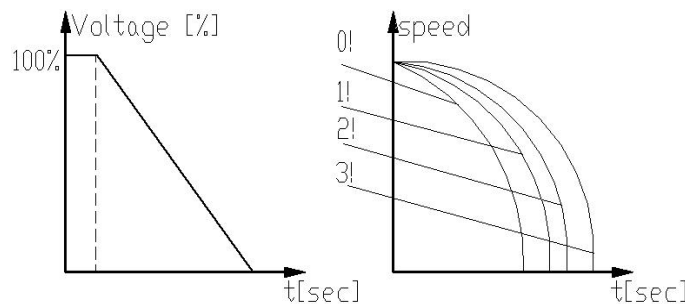

Figure 26: Stop curves

Curve 5 - Torque Curve - Provides linear deceleration of the torque. In certain loads, linear torque deceleration can result in close to linear speed deceleration.

The iStart Torque Control does not require any external torque or speed sensor (tacho-gen., etc.).

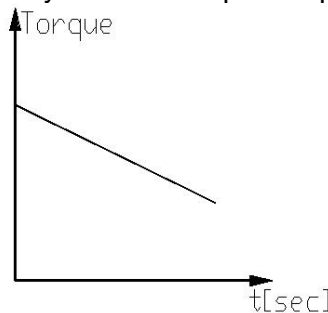

Figure 27: Curve 5 – Torque curve

Curve 9 (DOL) –

Direct Online soft stop curve opens the bypass and disconnects the motor directly – equivalent to stop operation.

WARNING!

When operating in SOFT START CURVE 1 motor must be loaded, otherwise, vibration may occur towards the end of the soft start process.

6.6.3 Special Features¹⁴ – page 6 of Professional and Expert Only

SPECIAL FEATURES PARAMETERS			
Display and default values	Range	Description	Remarks
SLOW SPEED TORQ 1 MIN	1(MIN) – 10(MAX)	Sets SLOW SPEED TORQUE.	These options are not available yet, even though the LCD enables their selection. For more information, contact Solcon's sales department. Note: When iStart is connected "Inside-Delta" SLOW SPEED TORQUE is not available.
MAX SLOW TIME 30 SEC	1–30sec. Note: Range can be extended to 250sec. by using the EXTEND SETTING.	Sets maximum time for SLOW SPEED TORQUE operation.	
SAVING ADJUST NO	YES/ NO		
EXTEND SETTING DISABLE	DISABLE/ ENABLE	Enables wider range of parameter settings.	For use in very special occurrences. Do not set to ENABLE unless starter is significantly larger than motor! See the detailed explanation on the next page.
3 OR 2 PHASE 3 PHASE START	3 PHASE START IGNOR PHASE 1 IGNOR PHASE 2 IGNOR PHASE 3	Defines which phases to use.	If there is a problem with one of the phases, you can short-circuit the problematic phase and set iStart to ignore that phase (operate in 2-phase mode).

¹⁴ Parameters that are available in Basic mode are in clear cells.

Parameters that are available in Professional and Expert mode, but not in Basic mode are in gray cells.

Parameters that are available in Expert mode only are in gray cells and highlighted.

6.6.3.1 Extend Setting

Parameter	EXTEND SETTING Disabled	EXTEND SETTING Enabled
INITIAL VOLTAGE	28-45%	25-60%
CURRENT LIMIT	100-400%	70-400%
ACCELERATION TIME	1-30 seconds	1-90 seconds
DECELERATION TIME	0-30 seconds	0-90 seconds
MAX. START TIME	1-30 seconds	1-250 seconds
PHASE LOSS Y/N	Yes ⁽¹⁾	Yes/No ⁽¹⁾
MAX SLOW TIME	1-30 seconds	1-250 seconds
O/C or WRONG CON protection in Inside Delta mode.	Protection active in normal set ⁽²⁾	Protection active in high set ⁽²⁾
OVERLOAD TRIP protection.	OVERLOAD TRIP will be active after Run LED is Lit. (Motor is at full voltage) ⁽³⁾	OVERLOAD TRIP will be active after MAX. START TIME has elapsed. ⁽³⁾

Notes:

(1) Refer to section 6.6.3.2 on page 66. See PHASE LOSS protection and refer to the warning below.

(2) Refer to section 10 on page 130. See O/C or WRONG CON protection.

(3) In order to avoid OVERLOAD TRIP in special cases (very high inertia loads), where at the end of the acceleration process, although motor is at full voltage (the **Run** LED is lit) and the current does not reduce to nominal, set EXTEND SETTING to ENABLE causing the OVERLOAD TRIP to be active only after MAX. START TIME has elapsed.

WARNING!
Operator's
Responsibility!

- EXTEND SETTING is for use in very special applications only!
Do not set EXTEND SETTING to ENABLE unless iStart is significantly larger than the motor! When you use EXTEND SETTING for the iStart, **you must** be extremely careful to avoid damaging the motor or iStart.
- Only cancel PHASE LOSS protection when the operator is sure that no real phase loss exists and PHASE LOSS protection is activated. This situation can occur in rare cases when there is no real fault, but the iStart recognizes unusual behaviour, like when THDV (Total Harmonic Distortion in Voltage) in the network is high.
If this is a true case of PHASE LOSS, then after you cancel PHASE LOSS protection the motor will single phase and most likely be tripped by the overload protection mechanism.

6.6.3.2 2 Phase Operation

To move to 2 phase operation, you must perform the following actions:

- Short between mains and the motor the phase that you want to short as follows:

Phase to Short	Connection on the iStart
Phase L1	1L1 to 2T1
Phase L2	3L2 to 4T2
Phase L3	5L3 to 6T3

- Change to Expert mode (on page 49).
- Enter the SPECIAL FEATURES menu and set 3 OR 2 PHASE to ignore the phase that you disconnected.
- Enter the START/STOP MOTOR menu and set SOFT START CURVE to 0, then set the SOFT STOP CURVE to 0. If there is more than one motor connected to the iStart, repeat in all of the START/STOP MOTOR menus.
- Enter the FAULT PARAMETERS menu and set M.UNBALANCE FLT to IGNORE.
- While still in the FAULT PARAMETERS menu, set GND FAULT FLT to IGNORE.
- While still in the FAULT PARAMETERS menu, set SHORTED SCR FLT to IGNORE.
- Start each of the motors and make sure that they start. If you forgot a step, the start will ramp up, but not complete.

6.6.4 Fault Parameters¹⁵ – Page 3 of Basic (page 5 of Professional and page 7 of Expert)

FAULT PARAMETERS - **** -		
Display and Default Values	Range	Description
HS OVR TMP FLT TRIP	IGNORE TRIP WARNING TRIP + WARNING	This parameter determines what to do if the temperature of the heat sink in the iStart exceeds the maximum allowed.
HS OVR TMP DLY 0.1 SEC	0.1 – 60.0 SEC	The time needed to enter the fault state.
HS OVR TMP AFTR 0.1 SEC	0.1 – 60.0 SEC	The time needed to exit the fault state.
SHORT CIRC FLT TRIP	IGNORE TRIP WARNING TRIP + WARNING	This parameter determines what to do if there is a short circuit.
SHORT CIRC DLY 0.1 SEC	0.1 – 60.0 SEC	The time needed to enter the fault state.
SHORT CIRC AFTR 0.1 SEC	0.1 – 60.0 SEC	The time needed to exit the fault state.
OVERLOAD FLT TRIP	IGNORE TRIP WARNING TRIP + WARNING	This parameter determines what to do if there is an overload.
OVERLOAD DLY 0.1 SEC	0.1 – 60.0 SEC	The time needed to enter the fault state.
OVERLOAD AFTR 0.1 SEC	0.1 – 60.0 SEC	The time needed to exit the fault state.
UNDER CURR FLT TRIP	IGNORE TRIP WARNING TRIP + WARNING	This parameter determines what to do if there is an undercurrent state.
UNDER CURR DLY 5.0 SEC	1.0 – 60.0 SEC	The time needed to enter the fault state.
UNDER CURR AFTR 0.1 SEC	0.1 – 60.0 SEC	The time needed to exit the fault state.
UNDER VOLT FLT TRIP	IGNORE TRIP WARNING TRIP + WARNING	This parameter determines what to do if there is an under volt state.
UNDER VOLT DLY 5.0 SEC	1.0 – 60.0 SEC	The time needed to enter the fault state.
UNDER VOLT AFTR 0.1 SEC	0.1 – 60.0 SEC	The time needed to exit the fault state.
OVER VOLT FLT TRIP	IGNORE TRIP WARNING TRIP + WARNING	This parameter determines what to do if there is an over volt state.

¹⁵ Parameters that are available in Basic mode are in clear cells.
Parameters that are available in Professional and Expert mode, but not in Basic mode are in gray cells.
Parameters that are available in Expert mode only are in gray cells and highlighted.

FAULT PARAMETERS - **** -		
Display and Default Values	Range	Description
OVER VOLT DLY 0.1 SEC	0.1 – 60.0 SEC	The time needed to enter the fault state.
OVER VOLT AFTR 0.1 SEC	0.1 – 60.0 SEC	The time needed to exit the fault state.
PHASE LOSS FLT TRIP	IGNORE TRIP WARNING TRIP + WARNING	This parameter determines what to do if 1 or 2 phases are missing. Notes: If iStart trips on PHASE LOSS do the following: (1) Verify that phase voltages are within the required range of the voltages. (2) If you are sure that no real phase loss exists, you can set PHASE LOSS to WARNING or IGNORE. This situation can occur in rare cases when there is no real fault but the iStart recognizes unusual behavior like when Total Harmonic Distortion in Voltage (THDV) in the network is high. (3) If this is a true case of PHASE LOSS, then after setting PHASE LOSS to WARNING or IGNORE, the motor will single phase and most likely be tripped by the over load protection mechanism. (4) Phase loss might not be detected in a motor operating under a light load.
PHASE LOSS DLY 0.1 SEC	0.1 – 60.0 SEC	The time needed to enter the fault state.
PHASE LOSS AFTR 0.1 SEC	0.1 – 60.0 SEC	The time needed to exit the fault state.
PHASE SEQ FLT TRIP	IGNORE TRIP WARNING TRIP + WARNING	This parameter determines what to do if there is a fault with the sequence of the phases.
PHASE SEQ DLY 0.1 SEC	0.1 – 60.0 SEC	The time needed to enter the fault state.
PHASE SEQ AFTR 0.1 SEC	0.1 – 60.0 SEC	The time needed to exit the fault state.
SHORTED SCR FLT TRIP	IGNORE TRIP WARNING TRIP + WARNING	This parameter becomes operational after the START signal. It determines what to do if one of these occur: <ul style="list-style-type: none"> • The motor is not properly connected to the starter's load terminals. • When internal disconnection in the motor winding is detected. • When one or more SCRs have been shorted.
SHORTED SCR DLY 0.1 SEC	0.1 – 60.0 SEC	The time needed to enter the fault state.
SHORTED SCR AFTR 0.1 SEC	0.1 – 60.0 SEC	The time needed to exit the fault state.
LNG STRT TM FL TRIP	IGNORE TRIP WARNING TRIP + WARNING	This parameter determines what to do if there is a long start.
LNG STRT TM DLY 0.1 SEC	0.1 – 60.0 SEC	The time needed to enter the fault state.

FAULT PARAMETERS _ **** _		
Display and Default Values	Range	Description
LNG STRT TM AFTR 0.1 SEC	0.1 – 60.0 SEC	The time needed to exit the fault state.
SLOW SPD TM FLT TRIP	IGNORE TRIP WARNING TRIP + WARNING	This parameter determines what to do if the motor speed is too slow.
SLOW SPD TM DLY 0.1 SEC	0.1 – 60.0 SEC	The time needed to enter the fault state.
SLOW SPD TM AFTR 0.1 SEC	0.1 – 60.0 SEC	The time needed to exit the fault state.
COMM T/O FLT TRIP	IGNORE TRIP WARNING TRIP + WARNING	This parameter determines what to do if a communication timeout causes a fault.
COMM T/O DLY 0.1 SEC	0.1 – 60.0 SEC	The time needed to enter the fault state.
COMM T/O AFTR 0.1 SEC	0.1 – 60.0 SEC	The time needed to exit the fault state.
EXT FAULT FLT TRIP	IGNORE TRIP WARNING TRIP + WARNING	This parameter determines what to do if there is an external trip.
EXT FAULT DLY 0.1 SEC	0.1 – 60.0 SEC	The time needed to enter the fault state.
EXT FAULT AFTR 0.1 SEC	0.1 – 60.0 SEC	The time needed to exit the fault state.
WRNG PARAMS FLT TRIP	IGNORE TRIP WARNING TRIP + WARNING	This parameter determines what to do if one of the values for an iStart parameter is outside of the defined limits for that parameter. To solve this problem, return iStart to the default settings, then reprogram it with all of the settings that you had before the fault occurred.
WRNG PARAMS DLY 0.1 SEC	0.1 – 60.0 SEC	The time needed to enter the fault state.
WRNG PARAMS AFTR 0.1 SEC	0.1 – 60.0 SEC	The time needed to exit the fault state.
COMM FAILED FLT TRIP	IGNORE TRIP WARNING TRIP + WARNING	This parameter determines what to do if there is a communication failure.
COMM FAILED DLY 0.1 SEC	0.1 – 60.0 SEC	The time needed to enter the fault state.
COMM FAILED AFTR 0.1 SEC	0.1 – 60.0 SEC	The time needed to exit the fault state.
TOO MANY FLT TRIP	IGNORE TRIP WARNING TRIP + WARNING	This parameter determines what to do if there are too many starts within the defined time period.
TOO MANY DLY 0.1 SEC	0.1 – 60.0 SEC	The time needed to enter the fault state.

FAULT PARAMETERS _ **** _		
Display and Default Values	Range	Description
TOO MANY AFTR 0.1 SEC	0.1 – 60.0 SEC	The time needed to exit the fault state.
MTOR INSUL FLT TRIP	IGNORE TRIP WARNING TRIP + WARNING	This parameter determines what to do if the wiring insulation causes a fault. Applicable only if optional insulation PCB and resistor unit are installed and connected. Insulation testing is enabled only when motor is not running and after 60 seconds in the <i>Stop</i> state. While the motor is running, the value of the insulation resistance shown in the actual data display is the last measured value prior to starting of the motor. While testing, if the insulation level drops below fault level, MOTOR INSUL will display and the insulation alarm relay will be energized. The <i>Fault</i> LED on the control keypad of the iStart will blink. If the insulation level will return to normal for more than 60 seconds the fault will automatically reset. While testing, if the insulation level drops below the fault level, MOTOR INSUL will display and the fault relay of the iStart will go to the fault position (as programmed in the I/O PROGRAMMING PARAMETERS). The <i>Fault</i> LED on the front of the iStart will light. In this status, the motor cannot be started. If the insulation level returns to normal, the iStart will not automatically reset.
MTOR INSUL DLY 0.1 SEC	0.1 – 60.0 SEC	The time needed to enter the fault state.
MTOR INSUL AFTR 0.1 SEC	0.1 – 60.0 SEC	The time needed to exit the fault state.
M OVR TMP FLT TRIP	IGNORE TRIP WARNING TRIP + WARNING	This parameter determines what to do if the external temperature sensor generates a fault.
M OVR TMP DLY 0.1 SEC	0.1 – 60.0 SEC	The time needed to enter the fault state.
M OVR TMP AFTR 0.1 SEC	0.1 – 60.0 SEC	The time needed to exit the fault state.
WRONG FREQ FLT TRIP	IGNORE TRIP WARNING TRIP + WARNING	This parameter determines what to do if the current is the wrong frequency .
WRONG FREQ DLY 0.1 SEC	0.1 – 60.0 SEC	The time needed to enter the fault state.
WRONG FREQ AFTR 0.1 SEC	0.1 – 60.0 SEC	The time needed to exit the fault state.
M.UNBALANCE FLT TRIP	IGNORE TRIP WARNING TRIP + WARNING	This parameter determines what to do if the phases at the motor are unbalanced.
M.UNBALANCE DLY 5.0 SEC	1.0 – 60.0 SEC	The time needed to enter the fault state.
M.UNBALANCE AFTR 0.1 SEC	0.1 – 60.0 SEC	The time needed to exit the fault state.
GND FAULT FLT TRIP	IGNORE TRIP WARNING TRIP + WARNING	This parameter determines what to do if there is a ground fault.

FAULT PARAMETERS _ **** _		
Display and Default Values	Range	Description
GND FAULT DLY 0.1 SEC	0.1 – 60.0 SEC	The time needed to enter the fault state.
GND FAULT AFTR 0.1 SEC	0.1 – 60.0 SEC	The time needed to exit the fault state.
NO CURRENT FLT TRIP	IGNORE TRIP WARNING TRIP + WARNING	This parameter determines what to do if there is an no-current state.
NO CURRENT DLY 0.1 SEC	0.1 – 60.0 SEC	The time needed to enter the fault state.
NO CURRENT AFTR 0.1 SEC	0.1 – 60.0 SEC	The time needed to exit the fault state.
NO CTR PWR FLT TRIP	IGNORE TRIP WARNING TRIP + WARNING	This parameter determines what to do if is no control voltage (or control voltage is lower than 90VAC).
NO CTR PWR DLY 0.1 SEC	0.1 – 60.0 SEC	The time needed to enter the fault state.
NO CTR PWR AFTR 0.1 SEC	0.1 – 60.0 SEC	The time needed to exit the fault state.
OVER CURR FLT TRIP	IGNORE TRIP WARNING TRIP + WARNING	This parameter determines what to do if there is an over-current state (see 6.6.1.1)
OVER CURR DLY 0.1 SEC	0.1 – 60.0 SEC	The time needed to enter the fault state.
OVER CURR AFTR 0.1 SEC	0.1 – 60.0 SEC	The time needed to exit the fault state.
SHEAR PIN FLT TRIP	IGNORE TRIP WARNING TRIP + WARNING	This parameter determines what to do if over current may have broken or weakened the virtual shear pin.
SHEAR PIN DLY 0.1 SEC	0.1 – 60.0 SEC	The time needed to enter the fault state.
SHEAR PIN AFTR 0.1 SEC	0.1 – 60.0 SEC	The time needed to exit the fault state.
WRONG VZC FLT IGNORE	IGNORE TRIP WARNING TRIP + WARNING	This parameter determines whether the three phases voltage have a normal phase of $120^{\circ} \pm 4^{\circ}$ degrees between any set of two phases.
WRONG VZC DLY 0.1 SEC	0.1 – 60.0 SEC	The time needed to enter the fault state.
WRONG VZC AFTR 0.1 SEC	0.1 – 60.0 SEC	The time needed to exit the fault state.
WELDED CON. FLT TRIP	IGNORE TRIP WARNING TRIP + WARNING	This parameter determines what to do if there is current when the iStart is in the stop state.
WELDED CON. DLY 1.0 SEC	0.5 – 60.0 SEC	The time needed to enter the fault state.

FAULT PARAMETERS - **** -		
Display and Default Values	Range	Description
WELDED CON. AFTR 1.0 SEC	0.5 – 60.0 SEC	The time needed to exit the fault state.
BYPASS FLT ¹⁶ TRIP	IGNORE TRIP WARNING TRIP + WARNING	This fault occurs with two different events: 1. If iStart had a problem recognizing the power card or Gisalba card during initialization. 2. If the control power is too low to close the bypass.
BYPASS DLY ¹⁶ 1.0 SEC	0.5 – 60.0 SEC	The time needed to enter the fault state.
BYPASS AFTR ¹⁶ 1.0 SEC	0.5 – 60.0 SEC	The time needed to exit the fault state.
NO CALIB FLT TRIP	IGNORE TRIP WARNING TRIP + WARNING	This fault occurs when no calibration parameter was entered.
NO CALIB DLY 1.0 SEC	0.5 – 60.0 SEC	The time needed to enter the fault state.
NO CALIB AFTR 1.0 SEC	0.5 – 60.0 SEC	The time needed to exit the fault state.

¹⁶ This menu only appears with size D and above.

6.6.5 Autoreset Params¹⁷ – Page 4 of Basic (page 6 of Professional and page 8 Expert)

AUTORESET PARAMS _ **** _		
Display and Default Values	Range	Description
GLOBAL AUTORESET DISABLE ALL	DISABLE ALL ENABLE ALL	DISABLE ALL = The Autoreset feature is disabled for all faults, regardless of what is defined for the fault. ENABLE ALL = The Autoreset feature is enabled. It is defined for each fault separately.
AUTORESET PARAMS _ **** _		
Display and Default Values	Range	Description
{FaultName} MODE AUTO RESET OFF	A.RESET DISABLE	iStart will not automatically reset after the fault occurs.
	WAIT UNTIL SOLVD	iStart automatically resets after the fault condition ends.
	WAIT # SECOND	iStart waits # seconds, then checks if the fault condition ended. If yes, iStart automatically resets. If the fault condition still exists, it rechecks every # seconds. X can be 10, 20, 30, 40 or 50.
	WAIT # MINUTE	iStart waits # minutes, then checks if the fault condition ended. If yes, iStart automatically resets. If the fault condition still exists, it rechecks every # minutes. X can be 1, 2, 3, 4, 5, 6, 7, 8, 9, 10, 15, 30 or 45.
	WAIT 1 HOUR	iStart waits 1 hour, then checks if the fault condition ended. If yes, iStart automatically resets. If the fault condition still exists, it rechecks every hour.
{FaultName} TRY ALWAYS AUTORESET	ALWAYS DO A. RST	iStart automatically resets indefinitely.
	ONLY: # TRIES	iStart automatically resets until the # of tries is reached. The TRY0 parameter determines whether a successful reset initializes the tries counter. # is a value from 1 – 100.
{FaultName} 1ST 1.0 SEC	0.0 – 900.0 SEC	iStart waits the amount of time defined before trying to reset for the first time. The next time this fault occurs, the DLY parameter will define the delay. There are two exceptions to this rule: 1. The RESET command is received. 2. TRY0 = YES and iStart enters the RUN state.
{FaultName} SLVD 10.0 SEC	0.0 – 60.0 SEC	After the fault is solved, iStart waits the time defined before attempting to reset.

¹⁷ Parameters that are available in Basic mode are in clear cells.
Parameters that are available in Professional and Expert mode, but not in Basic mode are in gray cells.
Parameters that are available in Expert mode only are in gray cells and highlighted.

AUTORESET PARAMS _****_		
Display and Default Values	Range	Description
{FaultName} DLY 10.0 SEC	0.0 – 900.0 SEC	After the 1 st attempt to reset, iStart waits the amount of time defined before trying to reset again.
{FaultName} TRY0 YES	YES NO	YES initializes the counter for the number of tries when a reset is successful. NO defines that the number of reset tries is finite. Once this number is reached the only way to reset the fault and enable start is to press the RESET button on the control panel. Pressing the RESET button initializes all reset counters, not just for the reset counter of the specific fault.
{FaultName} RNEN DISABLE DUR STRT	ENABLE DUR START DISABLE DUR STRT	ENABLE DUR START enables reset during start (while a start is in progress). DISABLE DUR STRT disables the reset operation during start (while a start is in progress).

6.6.6 I/O Programming Parameters¹⁸ – Page 5 of Basic (7 of Professional and 9 of Expert)

I/O PROGRAMMING PARAMETERS		
Display and Default Values	Range	Description
IN1 PROGRAMMING STOP	INACTIVE	This input is ignored.
	START	Start the motor.
	STOP	Stop the motor.
	SOFT STOP	Soft Stop the motor. Note: In multistart mode the WHICH MOTOR parameters define which motor to start.
	EXTERNAL TRIP	Receive a trip command from an external source.
	RESET	Reset the iStart when it is tripped. Note: The reset does not take place while the start command is being given.
	START=1,STOP=0	<ul style="list-style-type: none"> Start when a command is received. Stop when no command is received. Start when a command is received. Soft Stop when no command is received. Note: In multistart mode the WHICH MOTOR parameters define which motor to start.
	START=1,S.STOP=0	
	START 1ST ADJUST	Start 1st motor.
	START 2ND ADJUST	Start 2nd motor.
	START 3RD ADJUST	Start 3rd motor.
	START 4TH ADJUST	Start 4th motor.
	S.STOP 1ST ADJ.	Soft Stop 1st motor.
	S.STOP 2ND ADJ.	Soft Stop 2nd motor.
	S.STOP 3RD ADJ.	Soft Stop 3rd motor.
	S. STOP 4TH ADJ.	Soft Stop 4th motor.
	WHICH MOTOR BIT0 WHICH MOTOR BIT1	The two parameters work together to define which motor the following commands are for: <ul style="list-style-type: none"> START STOP SOFT STOP START=1,STOP=0 START=1,S.STOP=0 BIT1, BIT0 → Motor 0 , 0 → 1 0 , 1 → 2 1 , 0 → 3 1 , 1 → 4
	SLOW FORWARD	iStart will start the motor at slow speed in the forward direction.
	SLOW REVERSE	iStart will start the motor at slow speed in reverse.
	ENERGY SAVER	Supply voltage to the motor decreases (lowering the rotating magnetic field intensity), thus reducing the reactive current and copper/iron losses. Activated when the motor has a light load for a long time.
NO ENERGY SAVER	Cancels the Energy Saver.	

¹⁸ Parameters that are available in Basic mode are in clear cells.
 Parameters that are available in Professional and Expert mode, but not in Basic mode are in gray cells.
 Parameters that are available in Expert mode only are in gray cells and highlighted.

I/O PROGRAMMING PARAMETERS		
Display and Default Values	Range	Description
IN1 STATE MAINTAIN OPEN	MAINTAIN CLOSE MAINTAIN OPEN MOMENTARY CLOSE MOMENTARY OPEN	This setting defines what state creates a command.
IN1 MIN ACTIVE 0.1 SEC	0.1 – 0.5 SEC (increments of 0.1 SEC)	Delay until the ACTIVE command takes effect. Note: Range can be extended to 1.0 SEC by using the EXTEND SETTING.
IN1 MIN INACTIVE 0.1 SEC	0.1 – 0.5 SEC (increments of 0.1 SEC)	Delay until the INACTIVE command takes effect. Note: Range can be extended to 1.0 SEC by using the EXTEND SETTING.
IN2 PROGRAMMING SOFT STOP	Same as IN1 PROGRAMMING	Same as IN1 PROGRAMMING for input 2.
IN2 STATE MAINTAIN OPEN	MAINTAIN CLOSE MAINTAIN OPEN MOMENTARY CLOSE MOMENTARY OPEN	Same as IN1 STATE for input 2.
IN2 MIN ACTIVE 0.1 SEC	0.1 – 0.5 SEC (increments of 0.1 SEC)	Same as IN1 MIN ACTIVE for input 2.
IN2 MIN INACTIVE 0.1 SEC	0.1 – 0.5 SEC (increments of 0.1 SEC)	Same as IN1 MIN INACTIVE for input 2.
IN3 PROGRAMMING START	Same as IN1 PROGRAMMING	Same as IN1 PROGRAMMING for input 3.
IN3 STATE MAINTAIN CLOSE	MAINTAIN CLOSE MAINTAIN OPEN MOMENTARY CLOSE MOMENTARY OPEN	Same as IN1 STATE for input 3.
IN3 MIN ACTIVE 0.1 SEC	0.1 – 0.5 SEC (increments of 0.1 SEC)	Same as IN1 MIN ACTIVE for input 3.
IN3 MIN INACTIVE 0.1 SEC	0.1 – 0.5 SEC (increments of 0.1 SEC)	Same as IN1 MIN INACTIVE for input 3.
INPUT POLICY	LAST CMD ACTIVE	When commands arrive from different inputs, the last command is one that is implemented.
	FIRST CMD ACTIVE	When commands arrive from different inputs, the first command is one that is implemented. Note: If commands from more than one input arrive at the same time, the input with the higher priority is implemented. Refer to the INPUT PRIORITY parameter
	VIA PRIORITY	When commands arrive from different inputs, the command coming from the input with the highest priority is the one that is implemented. The priority is determined by the INPUT PRIORITY parameter.
INPUT PRIORITY IN1, IN2, IN3, COM		Priority goes from left (highest) to right (lowest).

I/O PROGRAMMING PARAMETERS		
Display and Default Values	Range	Description
RLY1 ACTION FAULT	INACTIVE	
	RUN IMMEDIATE	Active when there is start action.
	STARTING	Active during the start ramp. It stops when the bypass closes.
	END OF ACC	Not active during the start ramp. Active when the bypass closes.
	STOP	
	SOFT STOP	Active during ramp down.
	STOP IMMEDIATE	Active from ramp down and continues to be active while stopped.
	NOT 1ST MOTOR	Active when motors 2, 3, or 4 are to be acted upon.
	FAULT	Active while in a fault state.
	WARNING	Active while in a warning state.
RLY1 ON STATE ON=NO / OFF=NC	ON=NO / OFF=NC ON=NC / OFF=NO	Defines the ON state of the Relay 1. If it is Normally Open (NO) or Normally Closed (NC).
RLY1 ON DELAY 0.0 SEC	0.0 – 60.0 SEC	Sets the delay until for the ON command to take effect.
RLY1 OFF DELAY 0.0 SEC	0.0 – 60.0 SEC	Sets the delay time for the OFF command to take effect.
RLY2 ACTION END OF ACC	INACTIVE RUN IMMEDIATE STARTING END OF ACC STOP SOFT STOP STOP IMMEDIATE NOT 1ST MOTOR FAULT WARNING	Same as RLY1 ACTION for Relay 2.
RLY2 ON STATE ON=NO / OFF=NC	ON=NO / OFF=NC ON=NC / OFF=NO	Same as RLY1 ON STATE for Relay 2.
RLY2 ON DELAY 0.0 SEC	0.0 – 60.0 SEC	Same as RLY1 ON DELAY for Relay 2
RLY2 OFF DELAY 0.0 SEC	0.0 – 60.0 SEC	Same as RLY1 OFF DELAY for Relay 2.

6.6.7 Option Setting Parameters¹⁹ – Page 10 of Professional and page 12 of Expert

This page only appears if an option card was added to the iStart unit. The page that appears depends on the type of option card installed.

6.6.7.1 Option Setting Parameters for the Modbus Communication Card

COMM OPTION - MODBUS -		
Display and default values	Range	Description
BAUD RATE 115200 BPS	1200 – 115200 BPS	Sets the baud rate.
STOP BIT 1.0 BITS	0.5 – 2.0 BITS	Sets the number of stop bits.
PARITY CHECK NONE	NONE EVEN ODD	Sets whether there is a parity check.
SERIAL LINK NO. 1	1 - 248	Sets the Modbus serial link number.
COMM CHANGE PARAM NO	NO YES	For future use only.
CMD VIA COMM NO	NO YES	For future use only.
CMD VALID FOR 1.0 SEC	0 – 10.0 SEC	Sets the length of time during which the last command value is valid.
RESET CMD VALID NO	NO YES	Sets whether the RESET command is permanently valid.
COMM TIMEOUT 10.0 SEC	0 – 90 SEC	For future use only.
UPD COMM STEPS 1ST ACK THEN UPD 1ST UPD THEN ACK	1ST ACK THEN UPD 1ST UPD THEN ACK	Sets whether the transmitted data is checked before writing to memory, or after writing to memory.

6.6.7.2 Option Setting Parameters for the Profibus Communication Card

COMM OPTION - PROFIBUS -		
Display and default values	Range	Description
PROFI.NETWORK ID 126	1 - 126	Sets the network ID number for Profibus.
COMM CHANGE PARAM NO	NO YES	For future use only.
CMD VIA COMM NO	NO YES	For future use only.
CMD VALID FOR 1.0 SEC	0 – 10.0 SEC	Sets the length of time during which the last command value is valid.
RESET CMD VALID NO	NO YES	Sets whether the RESET command is permanently valid.
COMM TIMEOUT 10.0 SEC	0 – 90 SEC	For future use only.
UPD COMM STEPS 1ST ACK THEN UPD 1ST UPD THEN ACK	1ST ACK THEN UPD 1ST UPD THEN ACK	Sets whether the transmitted data is checked before writing to memory, or after writing to memory.

¹⁹ Parameters that are available in Professional and Expert mode, but not in Basic mode are in gray cells. Parameters that are available in Expert mode only are in gray cells and highlighted.

6.6.7.3 Option Setting Parameters for the Device Net Communication Card

COMM OPTION - DEVICE NET -		
Display and default values	Range	Description
D.NET.NETWORK ID 126	1 - 126	Sets the network ID number for Device Net.
COMM CHANGE PARAM NO	NO YES	For future use only.
CMD VIA COMM NO	NO YES	For future use only.
CMD VALID FOR 1.0 SEC	0 – 10.0 SEC	Sets the length of time during which the last command value is valid.
RESET CMD VALID NO	NO YES	Sets whether the RESET command is permanently valid.
COMM TIMEOUT 10.0 SEC	0 – 90 SEC	For future use only.
UPD COMM STEPS 1ST ACK THEN UPD 1ST UPD THEN ACK	1ST ACK THEN UPD 1ST UPD THEN ACK	Sets whether the transmitted data is checked before writing to memory, or after writing to memory.

6.6.7.4 Option Setting Parameters for the Thermistor Voltage Analog Card

ANALOG OPTION - THERMISTOR INPUT -		
Display and default values	Range	Description
OUTPUT OPTION Vrms OUTPUT	Vrms OUTPUT Irms OUTPUT PwrF OUTPUT Power OUTPUT I Zero OUTPUT Motor Un. OUTPUT Manual OUTPUT (Expert Mode)	Sets the iStart reading that will be output: Vrms (Range: 0% - 120% Rated Voltage), Irms (Range: 0% - 400% FLA), Power Factor, Power (in Watt - Up to 65535W), Leakage Current (Range: 0% - 100% FLA), Maximal different between phase RMS currents (Range: 0% - 100% FLA). Manual OUTPUT depends on the next parameter value.
MANUAL SETTING 50%	0 – 100%	Enables iStart to output fixed current within the range of 0mA to 20mA.
CURRENT RANGE 4 – 20 mA	0 – 20mA 4 – 20mA	Sets the current range. If the card is set to voltage output the user must choose the 0-20 mA option.
THERMISTOR TYPE PTC	PTC NTC	Sets the type of thermistor that is connected to iStart. Note: If this setting does not match the thermistor type actually connected, the reading will be incorrect.
LIMIT RESISTANCE 30000 OHM	100-30000 (in increments of 100 Ohm)	Sets the resistance limit in Ohms. Note: If during the start process, resistance exceeds the value defined, it will result in an OVER TEMPERATURE THERMISTOR trip.

6.6.7.5 Option Setting Parameters for the Temp. Relay 3In Analog Card

ANALOG OPTION - TEMP. RELAY-3IN -		
Display and default values	Range	Description
MAX TEMPERATURE 120 C	40 – 200C Note: Range can be extended to 0 – 250C by using the EXTEND SETTING	Sets the maximum temperature measured by the RTD thermal sensor. Note: If during the start process, the temperature of one or more sensors exceeds the value defined, it will result in an OVER TEMPERATURE THERMISTOR trip.

6.6.8 **Global Parameter**

GLOBAL PARAMETER - **** -		
Display and default values	Range	Description
SET TIME 00:00:00		Time in 24 hour hh:mm:ss format.
SET DATE 01/01/2014		Date in DD/MM/YYYY format.
DEFAULT DATA V/I/POWER FACTOR	ACTUAL TRIP ACTUAL WARNING RTD TEMPERATURE ²⁰ PTC TEMPERATURE ²¹ NTC TEMPERATURE ²² INTERNAL TEMP 3PH VOLTAGE 3PH CURRENT V/I/POWER FACTOR	Sets the default actual data display.
LCD CONTRAST [*****]	1-8	Sets the contrast of the LCD display.
LCD INTENSITY [*****]	1-8	Sets the intensity of LCD display.

6.6.9 **Statistical Data – page 11**

STATISTICAL DATA - **** -		
Display and default values	Range	Description
TOTAL ENERGY 0 KW/H		Displays total energy drawn by the motor in KWH.
LAST STRT PERIOD 0SEC		Displays last starting time in seconds. Starting time is the duration until motor's current reaches nominal.
LAST STRT MAX I 0 % FLA		Displays last starting maximum starting current.
TOTAL RUN TIME 0 HOURS		Displays Motor's total run time.

²⁰ RTD TEMPERATURE appears only when the 3XRTD Thermal Sensor card is installed.²¹ PTC TEMPERATURE appears only when the Thermistor Input and Analog Output card is installed.²² NTC TEMPERATURE appears only when the Thermistor Input and Analog Output card is installed.

STATISTICAL DATA _ **** _		
Display and default values	Range	Description
TOTAL # OF STRTS 0		Displays total number of starts.
LAST TRIP NO FAULT		Displays motor's last trip cause.
TRIP CURRENT 0 % FLA		Displays motor's current when motor was tripped by the iStart.
TOTAL # OF TRIPS 0		Displays total number of trips.
PREVIOUS TRIP -1 NO FAULT		Displays the motor's trip history.
PREVIOUS TRIP -2 NO FAULT		
PREVIOUS TRIP -3 NO FAULT		
PREVIOUS TRIP -4 NO FAULT		
PREVIOUS TRIP -5 NO FAULT		
PREVIOUS TRIP -6 NO FAULT		
PREVIOUS TRIP -7 NO FAULT		
PREVIOUS TRIP -8 NO FAULT		
PREVIOUS TRIP -9 NO FAULT		
PREVIOUS TRIP -10 NO FAULT		
RESET STATISTICA ENTER TO RESET	NO YES	Yes resets all statistical data.

6.7 Event Logger – page 8 for Basic (page 11 for Professional, page 12 for Expert)

The event log displays up to 100 events. The current event is not recorded.

01 is the most recent event, **02** the next most recent...**99** the next to oldest event and **00** is the oldest event.

6.7.1 Event Summary

The top level menu shows two lines.

- Line 1 displays the event number and type.
- Line 2 displays the date (dd/mm) and time (HH:MM:SS).

```
EVENT:07 STOP
05/07 16:43:02
```

The example above shows:

- Event 07 was a STOP command.
- The event occurred on the 5th of July at 16:43:02.

Event Type	Description	Remarks
START 1	Start motor # 1	
START 2	Start #2	
START 3	Start #3	
START 4	Start #4	
STOP 1	Stop #1	
STOP 2	Stop #2	
STOP 3	Stop #3	
STOP 4	Stop #4	
S.STOP1/S.STP1	Soft Stop #1	
S.STOP2/S.STP2	Soft Stop #2	
S.STOP3/S.STP3	Soft Stop #3	
S.STOP4/S.STP4	Soft Stop #4	
SOFT START	Soft Stop	
	Brakes	Not currently implemented.
	Clock	Not currently implemented.
CTRL ON	Control Power On	
CTRL OFF	Control Power Off	
SLOW	Slow Motor (Forward)	Not currently implemented.
REVERSE	Slow Motor (Reverse)	Not currently implemented.
IDLE	Motor Idle	
CLOSE B/P	Run	
TRIP	Trip	
EMPTY	Empty	Log record is empty. Not enough events occurred since the last log reset.

To see details, press the **Enter** key.

6.7.2 Event Details

The details level menu shows two lines.

- Line 1 is a constant repetition of the event number, date and time.
- Line 2 is a scrollable display. Use the ▼ or ▲ keys to navigate to additional details of the event.

```
(07) 05/07 16:43
OPER: STOP
```

```
(07) 05/07 16:43
FAULT: NO FAULT
```

```
(07) 05/07 16:43
CURRENT PH1: 0%
```

Order	Details Code	Description	Range	Remarks
1	OPER:	Operation		
2	FAULT			
3	CURR P1	Phase 1 current		
	VOLT P1	Phase 1 voltage		
	MAX CURR P1	Phase 1 current		
4	CURR P2	Phase 2 current		
	VOLT P2	Phase 2 voltage		
	MAX CURR P2	Phase 2 current		
5	CURR P3	Phase 3 current		
	VOLT P3	Phase 3 voltage		
	MAX CURR P3	Phase 3 current		

6.8 Actual Data View

Actual data is always displayed inside arrow brackets to show that you are viewing data and not setting parameters. Press the ▼ or ▲ keys to browse between the different types of data.

Display ²³	Description	Syntax Example
< - TRIP - > < - NO FAULT - >	When there is a trip, the - TRIP - view displays as the default data view. Refer to: Troubleshooting (Page 130)	
<WARNING 02/03> < OVERLOAD >	Displays line voltage and frequency. Frequency is displayed after start command only. Syntax: <ul style="list-style-type: none"> • XX refers to the order of the faults shown on the second line. 01 is the least recent fault. The highest number is the most recent fault. • YY refers to the total number of warnings that are active at that moment. • ZZZZZZ represents the name of the fault. Refer to section 6.6.4 Fault Parameters – Page 3 of Basic (page 5 of Professional and page 7 of Expert) on page 67 for details on each warning. 	<WARNING XX/YY> < ZZZZZZ >
<RTD TEMPERATUR> <54C 54C 54C>	Relevant only to the 3XRTD Thermal Sensor option card. Displays the temperature for each of the three different RTDs.	
<PTC TEMPERATUR> < GOOD >	Relevant only to the Analog card with Thermal input. Displays the whether thermistor resistance is good (within allowed range) or high (is above the allowed range).	
<NTC TEMPERATUR> < HIGH >	Relevant only to the Analog card with Thermal input. Displays the whether thermistor resistance is good (within allowed range) or high (is below the allowed range).	
<H/S TEMPERATUR> < 28C >	Displays the internal temperature of the heat sink. In sizes A, B and C, there is only one sensor and one temperature reading. In sizes D and above, there are three sensors and three corresponding temperature readings. The Fan or Fans are active when the H/S temperature rises above 50°C, and inactive when the temperature falls below 45°C.	
< FREQUENCY > < 50.0 Hz >	Displays the frequency of the line voltage. If no line voltage is connected, 0 Hz will be displayed.	
< CONTROL VOLT > < 230.0V >	Displays the control power in units of VAC.	
< V1: V2: V3:> < 0% 0% 0%>	Displays the line voltage and frequency. Frequency is displayed after start command only.	

²³ Data that are available in Basic mode are in clear cells.
Data that are available in Expert mode only are in gray cells and highlighted.

Display ²³	Description	Syntax Example
< I1: I2: I3:> < 0% 0% 0%>	Displays the operating current in each of the three phases as a percentage of motor FLA (Full Load Ampere).	
< I1A: I2A: I3A:> < 0 0 0 >	Displays the operating current in each of the three phases in absolute value [Ampere].	
<Vrms:Irms:PwrF:> < 0% 0% 0.00>	Displays the average voltage for a single cycle, the average current for a single cycle, and the power factor. The voltage is proportional to rated line voltage and the current is proportional to the corresponding FLA.	

6.8.1 Default Data View

You can set any of the views to be the default when there is no trip. To do this, select the view and press the **Enter** key. Alternately, you can set the default in the GLOBAL PARAMETERS > DEFAULT DATA parameter setting.

7. Starting Procedure

Note:

It is necessary to connect a motor to load terminals otherwise S.SCR or WRONG CONNECTION Protection is activated. Other loads such as light bulbs, resistors, etc. may also cause WRONG CONNECTION Fault.

	1	When mains voltage is connected to the iStart, even if control voltage is disconnected, full voltage may appear on the starter load terminals. Therefore, for isolation purposes, it is necessary to connect an isolating device before (upstream) the starter.
	2	Power factor correction capacitors or overvoltage protection devices must not be installed on starters load side. When required, install it on starter's line side.
	3	When using "Inside delta" connection, wrong connection of the starter or the motor, will seriously damage the motor; therefore make sure motor is connected properly!
	4	Do not interchange line and load connections
	5	Before starting the motor verify its rotation direction. If needed, disconnect the rotor from the mechanical load and verify the right rotation direction.
	6	Prior to Start up procedure make sure that line voltage and control voltage match the ones shown on the starter's name plate.
	7	When start signal is initiated and a motor is not connected to load terminals, the SHORT SCR or WRONG CONNECTION protection will be activated.

7.1 Standard Starting Procedure

Connect Control Supply. On LED will light.
 Review all parameters with Mode and Select keys Set parameters as required.
 If necessary, return to Default Parameters (see "Service Mode").
 Connect mains voltage to starter's line terminals.
Apply Start command

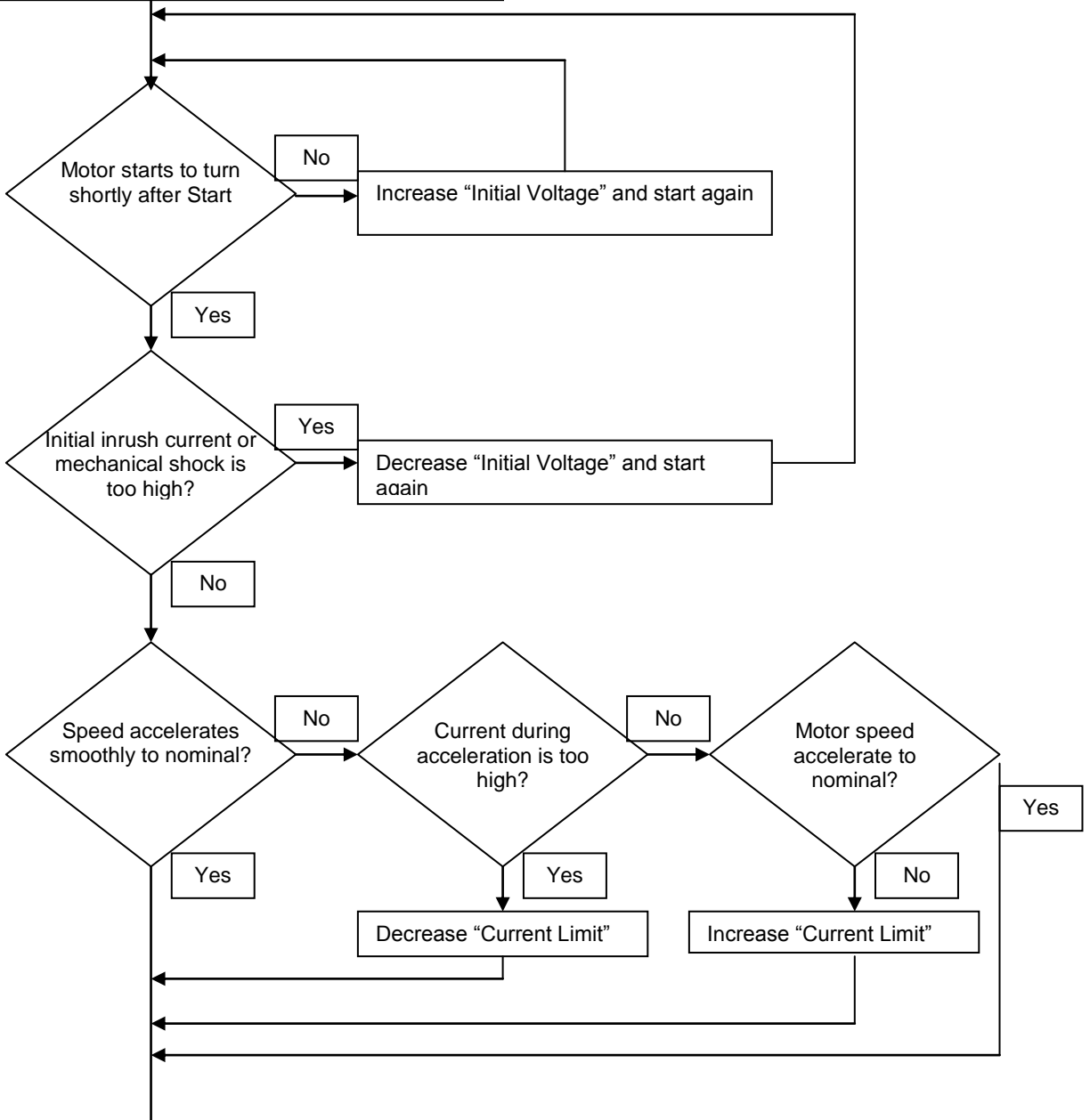

Apply Stop command and wait until motor stops.

Slightly increase Initial Voltage and Current Limit settings to allow for load changes.

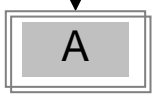

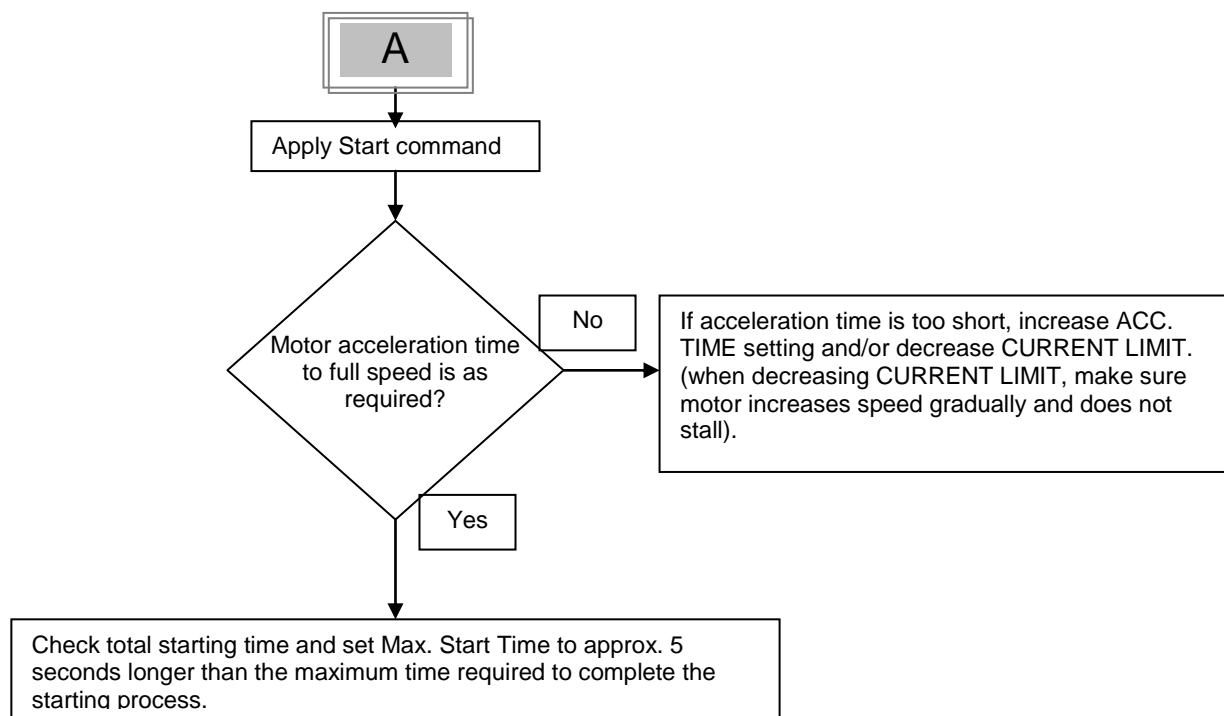

7.2 Examples of Starting Curves

7.2.1 Light Load-Pumps, Fans, Etc.

INITIAL VOLTAGE – set to 30% (Factory Default)
 CURRENT LIMIT – set 300%
 ACCELERATION TIME – set 5 sec

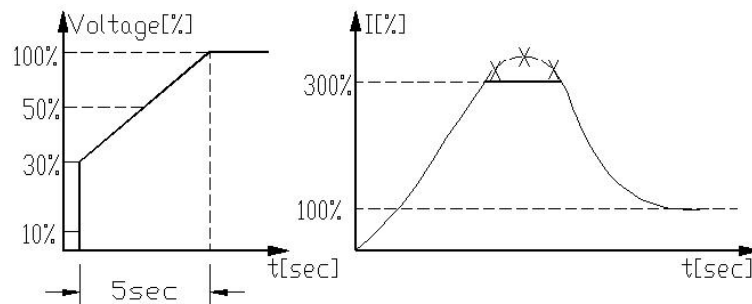

Figure 28: Starting curves (light load-pumps, fans, etc.)

Voltage quickly increases to the INITIAL VOLTAGE value and then gradually ramps-up to nominal. Current simultaneously and smoothly increases to reach CURRENT LIMIT setting or less, before smoothly decreasing to the operating current. Motor speed will accelerate to full speed quickly and smoothly.

7.2.2 High Inertia Loads – Fans, Centrifuges, Etc.

INITIAL VOLTAGE – set 50%
 CURRENT LIMIT – set 400%
 ACCELERATION TIME – set 20 sec

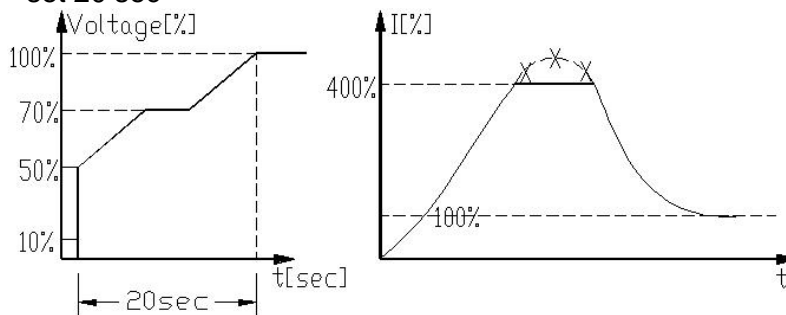

Figure 29: Starting curves (high inertia loads)

Voltage and current increase until current reaches CURRENT LIMIT. The voltage is held at this value until motor is close to nominal speed, then current will begin to decrease. The iStart continues to ramp-up the voltage until reaching nominal. Motor speed smoothly accelerates to full speed.

7.2.3 Choosing a Suitable Pump Curve (Centrifugal Pumps)

7.2.3.1 Starting Curve

- Adjust MAIN PARAMETERS as necessary (FLA, FLC, etc..)
- Set STARTING CURVE, ACCELERATION TIME, CURRENT LIMIT, and INITIAL VOLTAGE to their default values (curve 1, 10 sec., 400% and 30% respectively).
- Start the pump while watching the pressure gauge as the pump starts and look for overshooting (“Pressure Surge”) of the gauge needle above the target pressure. In case of over pressure, choose a peak torque reduction curve (Pump Control curve 2!).
- Set START CURVE 2!, increase ACCELERATION TIME to 15 seconds and reduce CURRENT LIMIT to 350%. Start the pump and watch the pressure gauge while the pump starts.
- In most cases, overshooting is reduced. If the overshoot persists, increase ACCELERATION TIME to 25 seconds (confirm with motor manufacturer) and try again.
- If the overpressure persists, increase START CURVE setting to 3!, or 4!. Each increase in START CURVE setting will reduce the Peak Torque, thus, reducing the overpressure and preventing the “Pressure Surge” during start.
- To increase starting time above these maximums, employ “Special Starting” for these techniques (Consult factory).

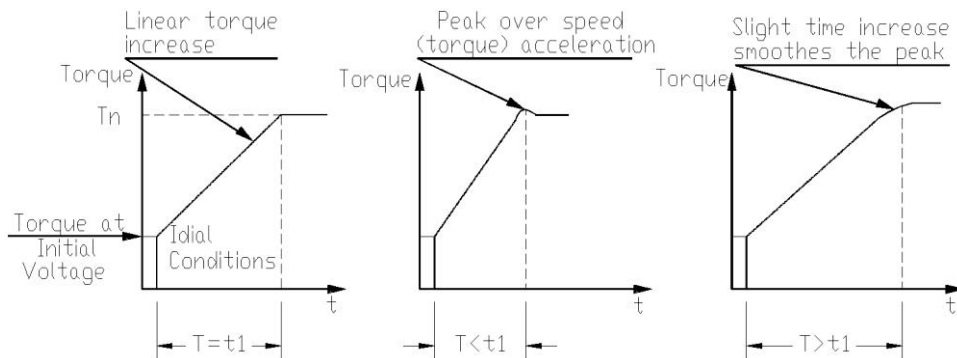

Figure 30: Starting curve

7.2.3.2 Stopping Curve

- Adjust MAIN PARAMETERS as necessary (FLA, FLC, etc..)
- Set STOP CURVE and DECELERATION TIME, to their default values (curve 0, 10 sec., respectively).
- Stop the pump, watching the pressure gauge and check valve as the pump stops. Look for overshooting (“Water Hammer”) of the gauge (abruptly stops the pump and the motor).
- Select STOP CURVE 2, increase DECELERATION TIME to 15 seconds. Stop the pump and watch the pressure gauge and the rate of closing of the check valve as the pump stops. Abrupt stopping of the pump and motor will cause a loud audible noise emitted from the check valve.
- In most cases, “Water Hammer” is reduced. If the “Water Hammer” persists, increase the time to 25 seconds (confirm with motor manufacturer) and try again.
- If the “Water Hammer” persists, increase STOP CURVE setting to 3!, or 4!. Each increase in STOP CURVE will reduce the abrupt stop of the pump, thus, preventing the “Water Hammer” phenomenon.

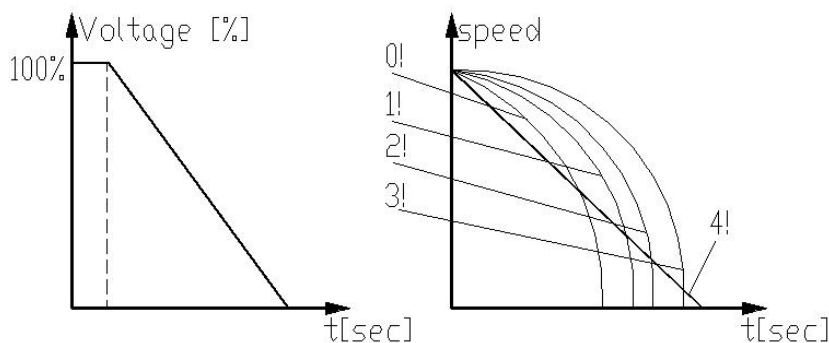

Figure 31: Stopping curve

7.2.3.3 *Final Torque During Soft-Stopping a Pump Motor*

While decelerating, the check valve may close before DECELERATION TIME has elapsed, thus, allowing current to flow through stator winding causing unnecessary heat. Select FINAL TORQUE sensitivity to 1, and stop the pump, confirm that current stopped flowing through the motor shortly after the check valve closed. If current still flows more than 3-5 seconds after check valve closure, increase FINAL TORQUE up to 10 if necessary, to stop current flow earlier

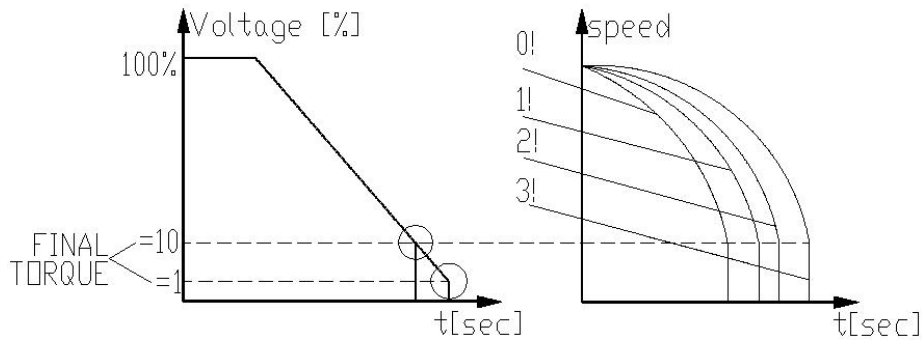

Figure 32: Final torque during soft-stopping a pump motor

8. COMMUNICATION

8.1 Modbus Communication

8.1.1 Features

- RS485 Hardware.
- Asynchronous serial link.
- Half duplex.
- Format: **Modbus RTU Mode** (Remote Terminal Unit Mode).
 - Binary.
 - Each character includes from 9.5 to 12 bits:
 - 1 start bit.
 - 8 data bits, LSB sent first.
 - 1 Parity bit, Even/Odd/No can be selected.
 - 0.5, 1, 1.5 or 2 Stop bits can be selected.
 - Cyclical Redundancy Check (CRC) for the entire frame, 16 bits.
- Baud Rates: 1200 up to 115200 bits per second can be selected.
- Response time of the iStart:
 - Normally, 1ms \leq time response \leq 40mS.
 - For a long response, time response \leq 100mS.
- **Setting Parameters cannot be set during Start, Soft Stop operations and when the motor is running.**

Notes:

You must connect the control panel earth to the iStart earth screw before connecting serial link wires. Ignoring this instruction may result in permanent damage to the serial link hardware.

- It is recommended to connect a 120 OHM resistor to the "+" and "-" pins of the serial link for proper RS485 Communication.
- Turn off (and on again) control power after changing the Baud Rate, Parity Check or Serial Link No. (slave address). These parameters can be modified only manually and not through the serial link.

8.1.2 Basic Structure of the Serial Link Frame

Modbus RTU frames have the same structure for both the "Query" transmissions from the Master to the Slave (iStart) and the response transmissions from the Slave to the Master:

Sync	Silent time of at least 3.5 character (3.5 * 11 bit times)	
Byte 1	Serial Link No. (= Slave Address)	(1 - 248)
Byte 2	Function	(3, 4, 6, 8 & 16 are supported)
Byte 3	Data Bytes	(0xXX)
.		(0xXX)
.		(0xXX)
Byte n-1	CRC Low	(0xXX)
Byte n	CRC High	(0xXX)

8.1.2.1 Sync (Silent Interval)

In RTU mode, a "Silent Interval" of blank 3.5 characters separates the transmission frames and synchronizes transmission.

The entire frame must be transmitted as a continuous stream.

A silent time of more than 3.5 character times during frame transmission will cause the receiving device to ignore the incomplete frame. The next byte will be assumed to be the Serial Link No. of the next frame.

If a second message is transmitted before 3.5 character times from the end of the previous one, the receiving device will consider it as a continuation of the first frame, thereby resulting in a CRC error and causing the receiving device to ignore the second frame.

8.1.2.2 Serial Link No. (Slave Address)

Contains iStart Slave Number (1 - 248) on the serial link. The iStart default value is 1. Serial Link No. is used as the first byte in both the "Query" transmission from Master to Slave and in response transmission from Slave to Master.

Note:

Address 0 that is normally used for broadcast is not supported by the iStart.

8.1.2.3 Function

The function code informs the iStart of the requested action to take. The function is used as the second byte in both the "Query" transmission from Master to Slave and in the "Response" transmission from Slave to Master.

8.1.3 **List of Functions Supported by the iStart**

Function	Modbas Name	Use in iStart
03	Read Holding Registers	Read Setting Parameters
04	Read Input Registers	Read Actual Data
06	Write Single Register	Write a Single Settings Parameter
08	Diagnostic	Check Communication
16	Force Multiple Registers	Write Settings Parameters Control Commands

8.1.3.1 Data

The Data field includes information that is transferred to and from the iStart. The specific data format changes according to the function. When Word data parameters are transmitted, the high byte is transmitted first, followed by the low byte.

8.1.3.2 CRC

The CRC (Cyclic Redundancy Check) has two bytes (16 bit) that are used to check the entire frame bytes. It is generated in the master device and transmitted as the last two bytes of the frame. The low byte is appended first, followed by the high byte.

The slave device regenerates the CRC bytes and compares them to the CRC bytes received. If the CRC bytes are not identical, the frame is flushed and no response is transmitted to the master.

8.1.3.3 iStart Memory Organization

The iStart memory is organized according to the common Modbus addresses as follows:

iStart Use	Memory Type	Max Query/Response Parameters
Actual Data	Read Word Registers,	# 1...160, addressed 1... 160
Setting Parameters	Read\Write Word Registers,	# 1...1900, addressed 1... 1900
Control Commands	Write Word Register,	# 1 addressed 5001

8.2 **Actual Data (Read Word Registers)**

Actual data includes measured values such as voltage, current and insulation resistance. It includes also logic information as well as statistic information. All parameters are word (two bytes) parameters. The protocol supports only Reading of these parameters.

The parameter addresses for all **actual data** have an offset of (-1).

For example: In order to read parameter # 5 – the user should call address 30004

Parameter	# (4x)	Comment
-----------	--------	---------

Parameter	# (4x)	Comment
Logic Status	1	Logic status of iStart. 1 indicates: Bit 15: iStart Tripped Bit 14: Motor Stopped Bit 13: Motor in Soft Stop Process Bit 12: Motor in Start Process Bit 11: Motor is Running Bit 10: Dual Adjust bit Bit 9: Triple Adjust bit Bit 8: Motor is running at Slow Speed forward Bit 7: Motor is running at Slow Speed reverse Bit 6: Insulation Alarm (Optional) Bit 5 - Bit 0: Reserved
Current	2	Current, % FLA
Voltage	3	Line voltage, % Rated Line voltage
Phase sequence Correct	4	1: Correct Phase Sequence 0: Wrong Phase Sequence
Hardwired inputs	5	Discrete Hardwired control Logic inputs Programmable to: Inactive Input, Start, Stop, Soft Stop, External trip, Reset, Start/Stop, Start/Soft Stop Bit 15 - Bit 3: Reserved. Bit 2: Logic input # 3 Status – 1: Active, 0: Inactive Bit 1: Logic input # 2 Status – 1: Active, 0: Inactive Bit 0: Logic input # 1 Status – 1: Active, 0: Inactive
Relays	6	Relay statuses Bit 15 – Bit 2: Reserved Bit 1: Relay # 2 Status – 1: Active, 0: Inactive Bit 0: Relay # 1 Status – 1: Active, 0: Inactive
Insulation Resistance	7	Motor Insulation, Kohm. (Optional)
I Zero Current	8	Ground leakage current, % FLA
I Motor Unbalanced Current	9	Max current deviation between phases, %
Frequency	10	Mains Frequency [0.1 Hz]
Thermistor Resistance	11	Thermistor resistance, tenth Kohm (Optional)
Power [Watt] – Low word	12	Power modulo 64K (65536)
Power [Watt] – High word	13	Power divided by 64K (65536) without the remainder
Power Factor	14	Power Factor * 100
Total run time [Sec] – Low word	15	Total Motor runtime modulo 64K (65536)
Total run time [Sec] – High word	16	Total Motor runtime divided by 64K (65536) without the remainder
Logic Status at Power Fail	17	Logic Status at Control Power Supply turned off
Total Run Time [Hour]	18	Total Hours of Motor runtime
Total Starts	19	Total Number of Starts
Last Start Period [Sec]	20	Duration of Last Start, Seconds
Last Start Peak I	21	Peak Current during Last Starting process, % FLA
Time to Re - Enable Start [Sec]	22	Wait time until next start command will be allowed
Total Trips	23	Total Number of Trips

Parameter	# (4x)	Comment
Last Trip Number	24	Number of the fault that caused trip 01 Over Temperature 02 Short Circuit Current 03 Overload 04 Under Current 05 Under Voltage 06 Over Voltage 07 Phase Loss 08 Phase Sequence 09 Shorted SCR or Wrong Connection. 10 Long Start Time 11 Slow Speed Time 12 MODBUS Timeout 13 External Fault 14 Wrong Parameters 15 COM Port Failed 16 Too Many Starts 17 Motor Insulation (Optional) 18 Thermistor (Optional) 19 Wrong Frequency 20 No Voltage 21 Over 7.5 * FLA current 22 Over 7.5 * FLC current 23 Motor Unbalance 24 Ground Fault 25 No Current 26 No Control power 27 Over Current (Inverse) 28 Shear Pin Current 29 Wrong VZC 30 Welded Contactor 31 No Calibration
Pre Trip I	25	Current at trip time, %FLA
Logic Input Status	26	
Version CRC16	27	The unique CRC16 Calculation of each SW Version
Phase Sequence	28	1: Positive, 0: Negative
Time To Over Current Trip	29	Time left until "Over Current" Trip occurs in seconds
COS Phi	30	Cos Phi * 100
Phase 1 Voltage	31	Phase 1 voltage, 0.1% Rated Line Voltage
Phase 2 Voltage	32	Phase 2 voltage, 0.1% Rated Line Voltage
Phase 3 Voltage	33	Phase 3 voltage, 0.1% Rated Line Voltage
Phase 1 Current	34	Phase 1 Current, 0.1% FLA
Phase 2 Current	35	Phase 2 Current, 0.1% FLA
Phase 3 Current	36	Phase 3 Current, 0.1% FLA
Energy [KWH] - Low word	37	Total Energy modulo 64K (65536)
Energy [KWH] - High word	38	Total Energy divided by 64K (65536) without the remainder
Energy per cycle - first word - MSB	39	Energy per cycle in Watts
Energy per cycle - second word	40	
Energy per cycle - third word	41	
Energy per cycle - forth word - LSB	42	
Reserved	43 - 47	
Analog option card - temperature 1	48	Thermistor or phase 1 RTD Temperature (Analog option cards), 0.1°K
Analog Option Card - Temperature 2	49	Phase 2 RTD Temperature (Analog Option Card), 0.1°K
Analog Option Card - Temperature 3	50	Phase 3 RTD Temperature (Analog Option Card), 0.1°K
Reserved	51 - 52	

Parameter	# (4x)	Comment
Phase 1 Temperature	53	Phase 1 internal temperature, Kelvin
Phase 2 Temperature	54	Phase 2 internal temperature, Kelvin
Phase 3 Temperature	55	Phase 3 internal temperature, Kelvin
Reserved	56 - 110	
Previous Trips	111 - 120	Trip numbers of 10 last trips - from latest to earliest.
Reserved	121 - 160	

8.2.1 Example 1: Read Actual Data

To read actual parameters 2 and 3 (Current and Voltage Actual Parameters, Addressed as 1 and 2) of iStart serial link # 18, the host computer should send following frame:

Byte	Description	Value
1	Serial Link No.	(0x12)
2	Function	(0x04)
3	Starting Address High	(0x00)
4	Starting Address Low	(0x01)
5	No. of Points High	(0x00)
6	No. of Points Low	(0x02)
7	CRC_Low	(0xXX)
8	CRC_High	(0xXX)

The iStart response, when Current = 400 % of FLA, and Voltage = 420V, is:

Byte	Description	Value	Comment
1	Serial Link No.	(0x12)	
2	Function	(0x04)	
3	Byte Count	(0x04)	
4	Data High, parameter 2	(0x01)	(400% FLA)
5	Data Low, parameter 2	(0x90)	
6	Data High, parameter 3	(0x01)	(420V)
7	Data Low, parameter 3	(0xA4)	
8	CRC_Low	(0xXX)	
9	CRC_High	(0xYY)	

The parameter addresses for all **actual data** have an offset of -1.
For example: In order to read parameter # 5, the user should call address 304

8.3 Setting Parameters (Read\Write Word Registers)

Setting parameters includes all parameters that can be set manually. These parameters determine the modes of operation of the iStart. They also set the protection level. All parameters are word (two bytes) parameters. The protocol supports both reading and modifying of (most of) these parameters.

The parameter addresses for all **setting parameters** have an offset of -1.

For example: In order to read parameter # 10, the user should call address 9.

Notes:

1. Use function 3 to read the setting parameters.
2. Use functions 6 and 16 to write the setting parameters.
3. Each of these parameters must set with care. Incorrect settings of some parameters can damage both the motor and the iStart.

8.3.1 Main Parameters

Parameter	#	Range	Default
Rated Line Voltage	1	190 - 600 V	400 (Volt)
Phase Sequence	2	0 - Ignore 1 - Positive 2 - Negative	0

Parameter	#	Range	Default
iStart FLC	3	17 - 1100	44 (Amp)
Motor Rated Power	4	1 - 3000	35 (KW)
Reserved	5		
Reserved	6		
O/C Shear Pin	7	100 - 850 (% of FLA)	400 (% of FLA)
Reserved	8		
Overload Class	9	IEC5 - NEMA60	IEC10
Overload Protect	10	0 - Disable 1 - Enable While Run 2 - Enable Always	0
Under Current Level	11	0 - 90 (% of FLA)	20 (% of FLA)
M.Unbalance Current Level	12	10 - 100 (% of FLA)	20 (% of FLA)
Ground Fault Current Level	13	1 - 60 (% of FLA)	20 (% of FLA)
Under Voltage Level	14	50 - 90 (% of Rated V)	75 (% of Rated V)
Over Voltage Level	15	109 - 125 (% of Rated V)	110 (% of Rated V)
Reserved	16		
Number of Starts	17	0 (OFF) 1 - 10	10
Start Period	18	1 - 60[Sec]	30[Sec]
Start Inhibit	19	1 - 60[Sec]	15[Sec]
Extended Settings	20	0 - Disable 1 - Enable	0 - Disable
Reserved	21		
Over Current Protect	22	0 - Disable 1 - Enable While Run 2 - Enable Always	0 - Disable
Over Current Curve Type	23	0 - IEC Curve C1 1 - IEC Curve C2 2 - IEC Curve C3 3 - IEC Curve C4 4 - IEC Curve C5 5 - US Curve U1 6 - US Curve U2 7 - US Curve U3 8 - US Curve U4 9 - US Curve U5	0 - IEC CURVE C1
Over Current IEC Time Dial	24	5 - TD 0.05 10 - TD 0.1 20 - TD 0.2 30 - TD 0.3 40 - TD 0.4 50 - TD 0.5 60 - TD 0.6 70 - TD 0.7 80 - TD 0.8 90 - TD 0.9 100 - TD 1.0	5 - TD 0.05

Parameter	#	Range	Default
Over Current US Time Dial	25	50 - TD 0.5 100 - TD 1 200 - TD 2 300 - TD 3 400 - TD 4 500 - TD 5 600 - TD 6 800 - TD 8 1000 - TD 10 1200 - TD 12 1500 - TD 15	50 – TD 0.5
Over Current Pick Up Current [% FLA]	26	100 150 200 250 300 350 400 450 500 550 600	100

8.3.2 Start Parameters (First Adjust)

Parameter	#	Range	Default
Motor FLA ²⁴	51	17 - 1100	44 (Amp)
Soft Start Curve	52	0 - Generator 1 - Standard 2 - Pump Curve 1 3 - Pump Curve 2 4 - Pump Curve 3 5 - Internal (Do Not Set) 6 - Internal (Do Not Set) 7 - Internal (Do Not Set) 8 - Internal (Do Not Set) 9 - DOL	1 - Standard
Initial Voltage ²⁵	53	25- 60	28 (% of full voltage)
Initial Current	54	0 - 400	0 (% of FLA)
Current Limit	55	70 - 400	400 (% of FLA)
Acceleration Time	56	1 - 90	10 (Seconds)
Max Start Time	57	1 - 250	30 (Seconds)
Pulse Type	58	0 - Pulse Disable 1 - Voltage Pulse 2 - Current Pulse	0 – Pulse Disable
Voltage Pulse Level	59	50 – 99	50 (% of full voltage)
Current Pulse Level	60	0 – 700	0 (% of FLA)
Pulse Rise Time	61	1 - 5	1 (0.1 seconds)
Reserved	62		
Pulse Constant Time	63	0 - 10	0 (0.1 seconds)
Pulse Fall Time	64	1 - 5	1 (0.1 seconds)
Reserved	65		

Note:

Start Parameters (second, third and fourth Adjust) have the same parameters. Their addresses are shifted from first adjust by: $((\text{Adjust Number} - 1) * 40)$.

For example: the "Pulse Rise Time" for third adjusts has the address:

$(\# \text{ Pulse Rise Time First Adjust}) + ((\text{Adjust} - 1) * 40) + \text{offset of } - 1 = 61 + 2*40 = 140$.

²⁴ The Motor FLA is Limited to: $0.5*FLC \leq \text{Motor FLA} \leq FLC!!!$

Any attempt to ignore these limits will cause a Comm. Error response.

²⁵ It is highly recommended not to change initial voltage if not necessary.

If a change is required - rise up initial voltage in minor steps.

8.3.3 Stop Parameters (First Adjust)

Parameter	#	Range	Default
Soft Stop Curve ²⁶	211	0 - Generator 1 - Standard 2 - Pump Curve 1 3 - Pump Curve 2 4 - Pump Curve 3	1 – Standard
Reserved	212		
Deceleration Time	213	0 - 30	30 (Seconds)
Reserved	214		

Note:

Stop Parameters (second, third and fourth Adjust) have the same parameters. Their addresses are shifted from first adjust by: $((\text{Adjust Number} - 1) * 20)$.

For example: the “Deceleration Time” for fourth adjusts has the address:

$(\# \text{Deceleration Time First Adjust}) + ((\text{Adjust} - 1) * 20) + \text{offset of } -1 = 213 + 3 * 20 = 272$.

8.3.4 Special Features Parameters

Parameter	#	Range	Default
Reserved	291 – 293		
Two Phase Mode ²⁷	294	0 - Three Phase Mode (Standard) 1 - Ignore Phase 1 2 - Ignore Phase 2 3 - Ignore Phase 3	0 - Three Phase Mode (Standard)
Light Duty Enable	295	0 - Disable 1 - Enable	0 - Disable

²⁶ Make sure that the Soft stop curve number is equal to the Soft start curve number.

²⁷ Before changing this parameter, carefully read the “Two phase mode” section in the user manual!

8.3.5 **Fault Parameters**

Parameter	#	Range	Default
Over Temperature Trip	311	0 - Disable Trip & Warning 1 - Enable Trip Only 2 - Enable Warning Only 3 - Enable Trip & Warning	1 - Enable Trip Only
Over Temperature Active Time	312	1 - 600 (0.1 sec)	1
Over Temperature Inactive Time	313	1 - 600 (0.1 sec)	1
No Calibration Trip	404	0 - Disable Trip & Warning 1 - Enable Trip Only 2 - Enable Warning Only 3 - Enable Trip & Warning	1 - Enable Trip Only
No Calibration Active Time	405	1 - 600 (0.1 sec)	1
No Calibration Inactive Time	406	1 - 600 (0.1 sec)	1

Notes:

1. The next fault parameters are the same as the ones above except for a few exceptions²⁸. Their addresses are shifted from first set (Trip, Active & Inactive time) by: $(\text{Fault Number} - 1) * 3$.

For example: the “Too Many Starts Inactive Time” has the address:

$(\# \text{ Over Temperature Inactive Time}) + ((\text{Fault Number} - 1) * 3) + \text{offset of } -1 = 313 + 15 * 3 = 4357$.

2. The complete list of fault parameters is listed on page 102.

²⁸ The Exceptions on the Fault Parameter page are:

Under Current Active Time	321	10 - 600 (0.1 sec)	Default : 50
Under Voltage Active Time	324	10 - 600 (0.1 sec)	Default : 50
Motor Unbalanced Active Time	378	10 - 600 (0.1 sec)	Default : 50
Wrong VZC Trip	395	0 – Dis., 1 – En.	Default : 0 – Disable
Welded Contactor Active Time	399	5 - 600 (0.1 sec)	Default : 10
Welded Contactor Inactive Time	400	5 - 600 (0.1 sec)	Default : 10

8.3.5.1 *Faults List*

#	Fault	#	Fault
01	Over Temperature	17	Motor Insulation (Optional)
02	Short Circuit Current	18	Thermistor (Optional)
03	Overload	19	Wrong Frequency
04	Under Current	20	No Voltage
05	Under Voltage	21	Over 7p5 FLA current
06	Over Voltage	22	Over 7p5 FLC current
07	Phase Loss	23	Motor Unbalance
08	Phase Sequence	24	Ground Fault
09	Shorted SCR or Wrong Connection.	25	No Current
10	Long Start Time	26	No Control power
11	Slow Speed Time	27	Over Current (Inverse)
12	MODBUS Timeout	28	Shear Pin Current
13	External Fault	29	Wrong VZC
14	Wrong Parameters	30	Welded Contactor
15	COM Port Failed	31	No Calibration ²⁹
16	Too Many Starts		

1. The No Calibration fault does not have an autoreset parameters group.²⁹

8.3.6 *Auto Reset Parameters*

Parameter	#	Range	Default
Auto Reset Global Enable	501	0 - Disable 1 - Enable	0 - Disable
Over Temperature When Active	502	0 - Disable Auto Reset for this fault 1 - Wait until solved 2 - Wait 10 sec to solve 3 - Wait 20 sec to solve 4 - Wait 30 sec to solve 5 - Wait 40 sec to solve 6 - Wait 50 sec to solve 7 - Wait 1 min to solve 8 - Wait 2 min to solve 9 - Wait 3 min to solve 10 - Wait 4 min to solve 11 - Wait 5 min to solve 12 - Wait 6 min to solve 13 - Wait 7 min to solve 14 - Wait 8 min to solve 15 - Wait 9 min to solve 16 - Wait 10 min to solve 17 - Wait 15 min to solve 18 - Wait 30 min to solve 19 - Wait 45 min to solve 20 - Wait 1 hour to solve	0 - Disable Auto Reset for this fault
Over Temperature Number of Tries	503	0 - No Limit 1 - 100	0 - No Limit
Over Temperature Delay of #1 Try	504	0 - 9000 (0.1 sec)	10
Over Temperature Delay between Tries	505	0 - 9000 (0.1 sec)	100
Over Temperature Wait for solved	506	0 - 600 (0.1 sec)	0
Over Temperature Clear Tries # Enable ³⁰	507	0 - Disable 1 - Enable	1 - Enable
Over Temperature after Start Enable	508	0 - Disable 1 - Enable	1 - Enable

Notes:

1. The next Auto-Reset parameters are the same as the ones above. Their addresses are shifted from first set (When Active, Number of Tries... after Start Enable) by: $((\text{Fault Number} - 1) * 7)$.

For example: the “No Control Power Wait for solved” has the address:

$(\# \text{Over Temperature Wait for solved}) + ((\text{Fault Number} - 1) * 3) + \text{offset of } -1 = 506 + 25 * 7 = 680$.

2. The complete list of fault parameters is listed on page 102.
3. The last fault (No Calibration) does not have an autoreset parameters group.

8.3.7 *I/O Programming Parameters*

Parameter	#	Range	Default
-----------	---	-------	---------

³⁰ The “Clear Tries # Enable”, if it is Enabled, clears the number of tries **only when a manually RESET is applied (via Keyboard or via Communication), not an Auto - Reset!!!**

Parameter	#	Range	Default
Input #1 Programming	901	0 - Do Nothing 1 - Soft Start 2 - Stop 3 - Soft Stop 4 - External Trip 5 - Reset 6 - Start or Stop 7 - Start or Soft Stop 8 - First Adjust Start 9 - Second Adjust Start 10 - Third Adjust Start 11 - Fourth Adjust Start 12 - First Adjust Soft Stop 13 - Second Adjust Soft Stop 14 - Third Adjust Soft Stop 15 - Fourth Adjust Soft Stop 16 - LSB Adjust 17 - MSB Adjust 18 - Slow Forward 19 - Slow Reverse 20 - Energy Saver 21 - No Energy Saver	2 - Stop
Input #1 Level	902	0 - Maintain Close 1 - Momentary Close 2 - Maintain Open 3 - Momentary Open	1 - Maintain Open
Input #1 Active Time	903	1 – 10 (0.1 sec)	1
Input #1 Inactive Time	904	1 – 10 (0.1 sec)	1
Input #2 Programming	905	0 - Do Nothing 1 - Soft Start 2 - Stop 3 - Soft Stop 4 - External Trip 5 - Reset 6 - Start or Stop 7 - Start or Soft Stop 8 - First Adjust Start 9 - Second Adjust Start 10 - Third Adjust Start 11 - Fourth Adjust Start 12 - First Adjust Soft Stop 13 - Second Adjust Soft Stop 14 - Third Adjust Soft Stop 15 - Fourth Adjust Soft Stop 16 - LSB Adjust 17 - MSB Adjust 18 - Slow Forward 19 - Slow Reverse 20 - Energy Saver 21 - No Energy Saver	3 - Soft Stop
Input #2 Level	906	0 - Maintain Close 1 - Momentary Close 2 - Maintain Open 3 - Momentary Open	1 - Maintain Open
Input #2 Active Time	907	1 – 10 (0.1 sec)	1

Parameter	#	Range	Default
Input #2 Inactive Time	908	1 – 10 (0.1 sec)	1
Input #3 Programming	909	0 - Do Nothing 1 - Soft Start 2 - Stop 3 - Soft Stop 4 - External Trip 5 - Reset 6 - Start or Stop 7 - Start or Soft Stop 8 - First Adjust Start 9 - Second Adjust Start 10 - Third Adjust Start 11 - Fourth Adjust Start 12 - First Adjust Soft Stop 13 - Second Adjust Soft Stop 14 - Third Adjust Soft Stop 15 - Fourth Adjust Soft Stop 16 - LSB Adjust 17 - MSB Adjust 18 - Slow Forward 19 - Slow Reverse 20 - Energy Saver 21 - No Energy Saver	1 - Soft Start
Input #3 Level	910	0 - Maintain Close 1 - Momentary Close 2 - Maintain Open 3 - Momentary Open	0 – Maintain Close
Input #3 Active Time	911	1 - 10 (0.1 sec)	1
Input #3 Inactive Time	912	1 – 10 (0.1 sec)	1
Input #4 Programming	913	0 - Do Nothing 1 - Soft Start 2 - Stop 3 - Soft Stop 4 - External Trip 5 - Reset 6 - Start or Stop 7 - Start or Soft Stop 8 - First Adjust Start 9 - Second Adjust Start 10 - Third Adjust Start 11 - Fourth Adjust Start 12 - First Adjust Soft Stop 13 - Second Adjust Soft Stop 14 - Third Adjust Soft Stop 15 - Fourth Adjust Soft Stop 16 - LSB Adjust 17 - MSB Adjust 18 - Slow Forward 19 - Slow Reverse 20 - Energy Saver 21 - No Energy Saver	0 - Do Nothing
Input #4 Level	914	0 - Maintain Close 1 - Momentary Close 2 - Maintain Open 3 - Momentary Open	0 – Maintain Close

Parameter	#	Range	Default
Input #4 Active Time	915	1 - 10 (0.1 sec)	1
Input #4 Inactive Time	916	1 – 10 (0.1 sec)	1
Inputs Priority	917	0 - input#1, input#2, input#3, comm. 1 - input#2, input#1, input#3, comm. 2 - input#2, input#3, input#1, comm. 3 - input#1, input#3, input#2, comm. 4 - input#3, input#1, input#2, comm. 5 - input#3, input#2, input#1, comm. 6 - input#1, input#2, comm., input#3 7 - input#2, input#1, comm., input#3 8 - input#2, input#3, comm., input#1 9 - input#1, input#3, comm., input#2 10 - input#3, input#1, comm., input#2 11 - input#3, input#2, comm., input#1 12 - input#1, comm., input#2, input#3 13 - input#2, comm., input#1, input#3 14 - input#2, comm., input#3, input#1 15 - input#1, comm., input#3, input#2 16 - input#3, comm., input#1, input#2 17 - input#3, comm., input#2, input#1 18 - comm., input#1, input#2, input#3 19 - comm., input#2, input#1, input#3 20 - comm., input#2, input#3, input#1 21 - comm., input#1, input#3, input#2 22 - comm., input#3, input#1, input#2 23 - comm., input#3, input#2, input#1	0 - input#1, input#2, input#3, comm.
Inputs Policy	918	0 – Last Command Active 1 – First Command Active 2 – Via Priority	2 – Via Priority
Relay #1 Program Activity	919	0 - Active at Never 1 - Active at Run Immediate 2 - Active at Starting 3 - Active at End of Acceleration 4 - Active at Stop 5 - Active at Soft Stop 6 - Active at Stop Immediate 7 - Active at Alternative Adjust 8 - Active at Fault 9 - Active at Warning	8 - Active at fault
Relay #1 Active Delay	920	0 – 600 (0.1 sec)	0
Relay #1 Inactive Delay	921	0 – 600 (0.1 sec)	0
Relay #1 Active Polarity	922	0 - Normally Open 1 - Normally Close	0 – Normally Open
Relay #2 Program Activity	923	0 – Never Active 9 - Active at Warning	3 - Active at end of acceleration
Relay #2 Active Delay	924	0 - 600 (0.1 sec)	0
Relay #2 Inactive Delay	925	0 - 600 (0.1 sec)	0
Relay #2 Active Polarity	926	0 - Normally Open 1 - Normally Close	0 – Normally Open
Reserved	927 – 933		

8.3.8 **Global Parameters**

Parameter	#	Range	Default
Language selected	1001	1 – English	1 – English The languages list is not uniform - Ask a Solcon sales representative for the list of languages for your iStart!
Seconds	1002	0 - 60	0
Minutes	1003	0 - 60	0
Hours	1004	0 - 23	0
Days	1005	1 - 31	1
Months	1006	1 - 12	1
Years	1007	2014 - 2050	2014
LCD Contrast	1008	1 - 8	6
LCD Intensity	1009	1 - 8	8
Reserved	1010	0 - 10	0
Default Actual Data Screen	1011	0 - Actual Trip 1 - Actual Warning 2 - RTD Temperature ³¹ 3 - PTC Temperature 4 - NTC Temperature 5 - Internal Temperature 6 - Frequency ³² 7 - Control Voltage 8 - 3 Phase Voltage 9 - 3 Phase Current %FLA 10 - 3 Phase Current Amps 11 - V/I/Power Factor	11 - V/I/Power Factor
Display Mode	1012	0 - Basic 1 - Professional 2 - Expert	0 – Basic
Parameters Lock	1013	0 - Locked 1 - Not Locked	1 – Not Locked

³¹ Values 2,3, and 4 are relevant for use with analog option cards only.

³² Values 6, and 7 are relevant for only some of the display states.

8.3.9 **Communication Parameters**

Parameter	#	Range	Default
No longer in use	1101		
Baud Rate	1102	12 - 1200 (bps) 24 - 2400 (bps) 48 - 4800 (bps) 96 - 9600 (bps) 192 - 19200 (bps) 384 - 38400 (bps) 768 - 76800 (bps) 1152 - 115200 (bps)	1152 - 115200 (bps)
Stop bit Length	1103	0 - 0.5 bit 1 - 1.0 bit 2 - 1.5 bit 3 - 2.5 bit	1 – 1.0 bit
Parity Check	1104	0 - None 1 - Even 2 - Odd	0 – None
Slave Address	1105	1 - 247	1
Comm. Program save	1106	0 - No, 1 - Yes	0 - No
Comm. Control	1107	0 - No, 1 - Yes	0 – No
Comm. CMD Hold Time	1108	0 - 100 (0.1 sec)	10
Comm. CMD Reset	1109	0 - No, 1 - Yes	0 – No
Comm. Timeout	1110	0 - 9000 (0.1 sec)	100
UPD Comm. Steps	1111	0 – Comm check before write 1 – Comm writes before check	0 – Comm check before write

Notes:

- Parameter # is "1 based". The address is 1 lower than the parameter #. For example address of parameter #1 is 0.
- When the Write Multiple Register function (16) is used to adjust one or more setting parameters, then if one or more setting parameters are out of range, or if it is beyond the allowed limit an Illegal_Data_Address (exception code 0x02) error response will be returned.
- It is possible to preset setting parameters only when motor is stopped.
When the motor is Soft Started, Soft Stopped, runs at a slow speed, the iStart ignores the Preset Multiple Register function. An Illegal_Function exception response (exception code 0x01) is returned by the iStart whenever its logic condition does not enable presetting.
- Always wait more than 0.5 sec after using Function16 to preset parameters before transmitting again to the same iStart.
- After changing one or more of Communication parameters – iStart Control Power needs to be shut-down in order that the changes will take effect.
- After setting iStart parameters, the user is responsible for reading and testing all changed setting parameters.

8.3.10 **Example 2: Read Setting Parameters**

To read the Adjust Soft Start Setting parameters #173 – 175 (addressed at 172 – 174) (Init Volt, Init Current and Current Limit) for motor number 4 attached to the iStart # 1, the host computer should send following frame:

Byte	Description	Value	Comments
1	Serial Link No.	(0x01)	
2	Function	(0x03)	
3	Starting Address High	(0x00)	Address = 172 (173 - 1)
4	Starting Address Low	(0xAC)	
5	No. of Registers High	(0x00)	
6	No. of Registers Low	(0x03)	

Byte	Description	Value	Comments
7	CRC Low	(0xXX)	
8	CRC High	(0xYY)	

The iStart normal response:

Byte	Description	Value	Comments
1	Serial Link No.	(0x01)	
2	Function	(0x03)	
3	Byte Count	(0x06)	
4	Data High	(0x00)	Init Volt = 0
5	Data	(0x1C)	
6	Data High	(0x00)	Init Current = 0%
7	Data Low	(0x00)	
8	Data High	(0x01)	Current Limit = 400%
9	Data Low	(0x90)	
10	CRC Low	(0xXX)	
11	CRC High	(0xYY)	

8.3.11 Example 3: Write a Single Setting Parameter

To write a single setting parameter (Under Voltage Level = 80%) to Setting Parameter # 14 (addressed as 13) of iStart Serial Link # 7, the host computer should send following frame:

Byte	Description	Value	Comments
1	Serial Link No.	(0x07)	
2	Function	(0x06)	
3	Starting Address High	(0x00)	Address =13 (14-1)
4	Starting Address Low	(0x0D)	
5	Data High	(0x00)	80% of rated line voltage
6	Data Low	(0x50)	
7	CRC Low	(0xXX)	
8	CRC High	(0xYY)	

The iStart normal response is an echo of the query:

Byte	Description	Value	Comments
1	Serial Link No.	(0x07)	
2	Function	(0x06)	
3	Starting Address High	(0x00)	Address =13 (14-1)
4	Starting Address Low	(0x0D)	
5	Register Value High	(0x00)	
6	Register Value Low	(0x50)	
7	CRC Low	(0xXX)	
8	CRC High	(0xYY)	

8.3.12 Example 4: Write Multiple Setting Parameters

To write multiple setting parameters (Ground Fault Current Level= 75%, Under Voltage Level = 40%, Over Voltage Level = 120%) to Setting Parameters # 13-15 (addressed as 12 - 14) of iStart # 128, the host computer should send following frame:

Byte	Description	Value	Comments
1	Serial Link No.	(0x80)	
2	Function	(0x10)	
3	Starting Address High	(0x00)	
4	Starting Address Low	(0x0C)	
5	No. of Registers High	(0x00)	
6	No. of Registers Low	(0x03)	
7	Byte Count	(0x06)	
8	Data High	(0x00)	Address = 75
9	Data Low	(0x4B)	
10	Data High	(0x00)	Address = 40
11	Data Low	(0x28)	
12	Data High	(0x00)	Address = 120
13	Data Low	(0x78)	
14	CRC Low	(0xXX)	
15	CRC High	(0xYY)	

The iStart normal response:

Byte	Description	Value
1	Serial Link No.	(0x80)
2	Function	(0x10)
3	Starting Address High	(0x00)
4	Starting Address Low	(0x0C)
5	No. of Registers High	(0x00)
6	No. of Registers Low	(0x03)
7	CRC Low	(0xXX)
8	CRC High	(0xYY)

Note:

After setting iStart parameters, the user is responsible for reading and testing all setting parameters. When Preset Multiple Register Function (16) is used to adjust one or more setting parameters, an Illegal_Data_Address (exception code 0x02) error response will be returned if one of the following conditions exist:

- One or more setting parameters are out of range
- Preset Multiple Register Function (16) is outside the allowed range.

8.4 Control Register Write (Write Word Register)

The iStart incorporates one Control Register for controlling the iStart.

The Control Register is register #1, addressed at 45000.

In order to control the iStart using the Control register:

- Use Function 16 only.
- Use Address High = 0x13
- Use Address Low = 0x88.
- Write to one register only.
- Use data high (MS-Byte of data) = 0x5A.

- Data low Bits resolution of the control register (LS-Byte of data):

Bit	Function	Comment	
0	Stop	Write "1" (ON) to stop.	
1	Soft Stop	Write "1" (ON) to Soft Stop	
2	Start	Write "1" (ON) to start	
3	Triple Adjust	Write "1" (ON) to turn On Write "0" (OFF) to turn Off	
4	Dual Adjust	Write "1" (ON) to turn On Write "0" (OFF) to turn Off.	
5	Slow Speed	Write "1" for Slow Speed Write "0" for normal Start	// Inactive – For future use!!
6	Slow Spd Reverse	Write "1": for Reverse Direction Write "0" for Forward Direction	// Inactive – For future use!!
7	Reset	Write "1" (ON) to Reset.	

Notes:

1. It is not possible to read the function of the control register. To read the iStart status, read the Logic Status (actual parameter # 1 – address 0).
2. Bytes 2 - 8 of the control frame must be exactly as in Example 5 - Control Register Write on page 113e. Otherwise, an error message will be returned.
3. **Warning:** Before applying Start Command via Comm. – make sure you have at least one I/O Logic Input that is set to stop and have higher priority than Comm.

8.4.1 Example 5 - Control Register Write

To start iStart # 1, the host computer should send the following query frame:

Byte	Description	Value	Comments
1	Serial Link No.	(0x01)	
2	Function	(0x10)	Bytes 2 - 8 must be as in this example!!!
3	Starting Address High	(0x13)	
4	Starting Address Low	(0x88)	
5	No. of Registers High	(0x00)	
6	No. of Registers Low	(0x01)	
7	Byte Count	(0x02)	
8	Data High	(0x5A)	
9	Data Low	(0x04)	Bit 2 is set to Start.
10	CRC Low	(0xXX)	
11	CRC High	(0xYY)	

The iStart normal response:

Byte	Description	Value
1	Serial Link No.	(0x01)
2	Function	(0x10)
3	Starting Address High	(0x13)
4	Starting Address Low	(0x88)
5	No. of Registers High	(0x00)
6	No. of Registers Low	(0x01)
7	CRC Low	(0xXX)
8	CRC High	(0xYY)

8.5 Diagnostics

Modbus function 08, as implemented in the iStart, tests the communication serial link between the master and the iStart.

iStart only supports return query data (sub-function 0x00).

To request iStart with serial link # 1 to return query data, the master should send the following query frame:

Byte	Description	Value
1	Serial Link No.	(0x01)
2	Function	(0x08)
3	Sub-function High	(0x00)
4	Sub-function Low	(0x00)
5	Data High	(0x37)
6	Data Low	(0xA5)
7	CRC_Low	(0xXX)
8	CRC_High	(0xYY)

The normal (if no exception) response is the echo of the Query:

Byte	Description	Value
1	Serial Link No.	(0x01)
2	Function	(0x08)
3	Subfunction High	(0x00)
4	Subfunction Low	(0x00)
5	Force Data High	(0x37)
6	Force Data Low	(0xA5)
7	CRC_Low	(0xXX)
8	CRC_High	(0xYY)

8.6 Exception Responses

When the master sends a query frame to an iStart, one of the following four responses from the iStart is possible:

1. When no communication error is detected in the query, and no mistake is found by the communication program module in the iStart, a normal response is returned.
2. If the iStart does not receive the query frame (for example because of disconnected serial link cable) then no response is returned by the iStart. After the comm timeout is reached, the master will timeout.
3. If the iStart receives the query, but faulty CRC bytes and/or Parity bits are detected, then no response is returned by the iStart. After the comm timeout is reached, the master will timeout.
4. If no communication error is detected in the query, but the iStart communication program module finds an error such as illegal Function, data address or data value, or if the iStart is busy, then an Exception response is returned. The Exception response includes an Exception Code to inform the master about the type of the error.

8.6.1 Exception Code Response Frame

Exception response frame holds fix number of 5 Bytes. The first one, the Slave Address field is the Serial link number (transmitted in query and identical to iStart Serial Link No.). The second byte, the Function field returns the echo of the transmitted query function, but with the MSB set to 1 (adding 0x80 to the transmitted function code). The third Byte is the Exception Code informing about the type of error. Last two bytes are the CRC bytes.

8.6.2 Exception Codes Supported by the iStart

Code	Type	Comment
01	Illegal Function	Requested function is not supported. Functions 3, 4, 6, 8 and 16 are supported.
02	Illegal Data Address	Data address is outside the allowed range.
03	Illegal Data Value	Data value is not a legal value.
04	Slave Device Failure	Data value is not a legal value when reading from an external EEPROM.
06	Slave Device Busy	iStart is busy now. The master should transmit the message again later.

8.6.3 Example 6: Exception Response

When you write an illegal value to a single setting parameter (Under Voltage Level = 128%) to Setting Parameter # 14 (addressed as 13) of iStart Serial Link #10, the host computer should send following frame:
Query:

Byte	Description	Value	Comments
1	Serial Link No.	(0x0A)	
2	Function	(0x06)	
3	Starting Address High	(0x00)	Address =13 (14-1)
4	Starting Address Low	(0x0D)	
5	Data High	(0x00)	128% of rated line voltage
6	Data Low	(0x80)	
7	CRC Low	(0xXX)	
8	CRC High	(0xYY)	

Exception Response:

Byte	Description	Value	Comments
1	Serial Link No.	(0x0A)	
2	Function	(0x86)	Original + 0x80
3	Exception Code	(0x03)	Illegal Data Value
4	CRC_Low	(0xXX)	
5	CRC_High	(0xYY)	

Note:

There are cases where the iStart returns a normal response, but the requested action cannot be performed, or is modified by the table below.

Master Action	iStart Action
Write setting parameters during start process	Ignored.
Write too few parameters (Function 16) or some of the parameters are outside of allowed range	Limiting to allowed range.
Start command (Function 05) while the hardwired Stop Input is open	Command ignored if the specific input has a higher priority than the comm input. Refer to I/O Programming parameters Inputs Priority (917) and Inputs Policy (918).

It is the user's responsibility to verify that the requested action was performed, by reading the value of the modified parameters or the status of the command coils.

8.7 Profibus Communication

8.7.1 Global Parameters

Code Sample 1: Global Parameters in the GSD file

```

33: ;=====
34: ;==== General DP Keywords =====
35: ;=====
36:
37: GSD_Revision      = 5
38: Vendor_Name       = "Solcon Ltd"
39: Model_Name        = "iStart"
40: Revision           = "1.00"
41: Ident_Number      = 0xAFFE
42: Protocol_Ident    = 0
43: Station_Type      = 0
44: FMS_supp          = 0
45: Hardware_Release  = "V1.00"
46: Software_Release  = "V1.00"
47: Redundancy        = 0
48: Repeater_Ctrl_Sig = 2
49: 24V_Pins          = 0

```

8.7.2 Operation Mode in Profibus

iStart supports both DPV0 and DPV1.

- DPV0 (Cyclic) allows:
 - Starting and shutdown.
 - Reading parameters (writing parameters is not allowed at DPV0).
- DPV1 allows:
 - Everything that DPV0 allows.
 - Changing the cyclic parameters that display in DPV0.
 - Writing to registers.

8.7.3 Description of the DPV0 (Cyclic) Frame

From the Profibus controller to the iStart, two bytes (16 bits) are transferred.
 From the iStart to the controller, 40 bytes are transferred.

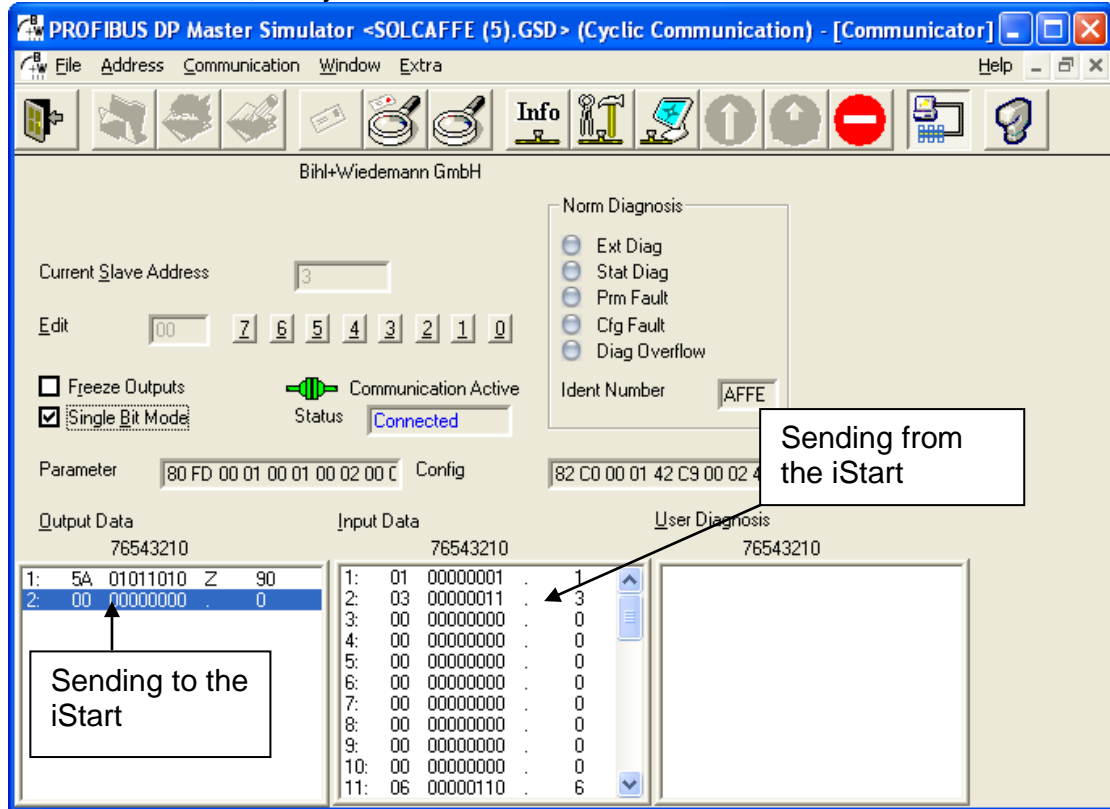

Figure 33: DPV0 parameters (Cyclic parameters)

8.7.3.1 Structure of the iStart Reception Frame

iStart can contain four different Start/Stop settings. In the LCD, these are displayed as Adjust settings.

- The first byte must be 0x5A (90 decimal).
- The second byte is as follows:

Table 1: iStart Receiving Frame – Byte 2

Bit ³³	Function	Value
0	Stop	1 = stop
1	Soft Stop	1 = soft stop
2	Start	1 = start
3	MSB	Refer to Table 2
4	LSB	
5	Slow Speed	0 = normal speed 1 = slow speed
6	Slow Spd Reverse	0 = forward direction 1 = reverse direction
7	Reset	1 = reset

Table 2: LSB and MSB values for bits 3 and 4

Adjust number	LSB	MSB
first adjust (default)	0	0
second adjust	1	0
third adjust	0	1
fourth adjust	1	1

Example:

To send a Reset, send 0x5A followed by 0x80.

8.7.3.2 Structure of the iStart Transmission Frame

The return frame contains 20 pairs of bytes (40 bytes total). Each pair of bytes represents one register, and is a 16 bit (Word) number. The first byte represents the MSB, which is the highest value.

8.7.3.3 Choosing the Reception DPV0 Registers

The return frame contains 20 registers. Each register contains two bytes (one word, 16 bits).

There are two different ways to edit the order of the registers that are displayed in DPV0:

- Change the parameters in the GSD file.
- Send a data request (only by DPV1).

8.7.3.3.1 Using GSD to Select the Registers to Display in DPV0

Lines 503 to 534 of the GSD file contain a list of parameters.

The parameters appear in blocks, each block contains 4 lines, and each block refers to one register (there are 20 blocks, which represent 20 registers).

The second line of each block starts with `Unsigned 16` followed by the number of the register (shown in green). Refer to 8.7.7 Actual Data Register Numbers (Decimal) on page 123 for the list of register numbers.

Code Sample 2: GSD file, the part that responsible to the registers that show at DPV0 (cyclic)

```
190: ExtUserPrmData = 1001 "INDIREC PAR 1"
191: Unsigned16 1 1-1000
192: Prm_text_Ref = 100
193: EndExtUserPrmData
194:
196: ExtUserPrmData = 1002 "INDIREC PAR 2"
197: Unsigned16 2 1-1000
198: Prm_text_Ref = 100
```

³³ Bit 0 is the LSB

```

199: EndExtUserPrmData
200:
201: ExtUserPrmData = 1003 "INDIREC PAR 3"
202: Unsigned16 3 1-1000
203: Prm_text_Ref = 100
204: EndExtUserPrmData
205:
.....
.....
284:
285: ExtUserPrmData = 1020 "INDIREC PAR 20"
286: Unsigned16 22 1-1000
287: Prm_text_Ref = 100
288: EndExtUserPrmdata

```

8.7.3.3.2 Using a Data Request (DPV1) to Select the Registers to Display in DPV0

You can change the register that displays in DPV0 by editing Slot number 1 and Index 2. Each register consists of 16 bits (two bytes/one word). The first byte represents the MSB of the register number.

To demonstrate this, we will use a simple PROFIBUS master³⁴ to change parameters so that we can see the following registers in DPV0 (cyclic):

1. Logic Status.
2. Current.
3. Voltage.
4. Power.
5. Power Multiplier.
6. Power Factor.
7. Control In.
8. Control Out.
9. Thermistor Resistance.
10. Insulation Resistance.

Step 1: The first thing that we need to do is to find the number of the registers in to 8.7.7 Actual Data Register Numbers (Decimal) on page 123.

Table 3: Number of the registers for the sample parameters

<u>Register name</u>	<u>Decimal number</u>	<u>Hex number</u>
Logic Status	1	00 01
Current	2	00 02
Voltage	3	00 03
Power	12	00 0C
Power Multiplier	13	00 0D
Power Factor	14	00 0E
Hardwired inputs	5	00 05
Relays	6	00 06
Themistor Resistance	11	00 0B
Insulation Resistance	7	00 07

Step 2: Update the register numbers.

³⁴ The PROFIBUS master is very simple and allows you to modify the parameters only by writing the hex numbers.

By writing the above numbers to Slot number 1 and Index number 2 through Data Request (by DPV1), we update the registers list that is displayed in DPV0.

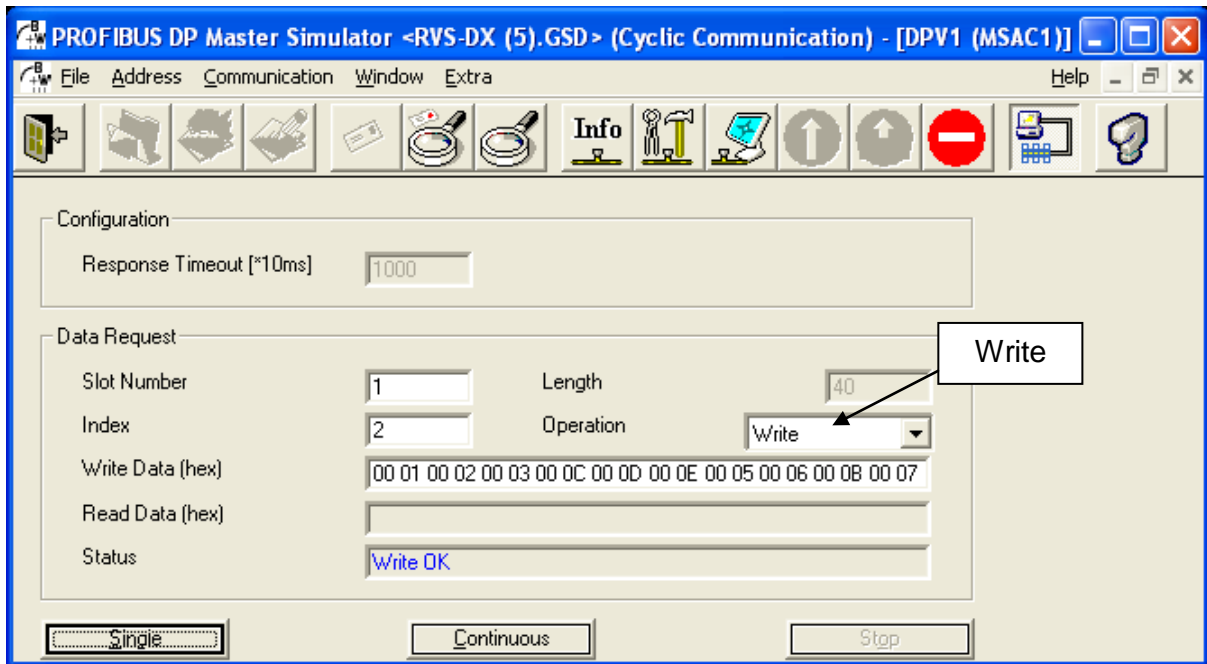

Figure 34: Updating the register number that will display at DPV0 (by Data Request)

Also, it is easy to read this list by reading from Slot number 1 and Index number 2 through Data Request (by DPV1).

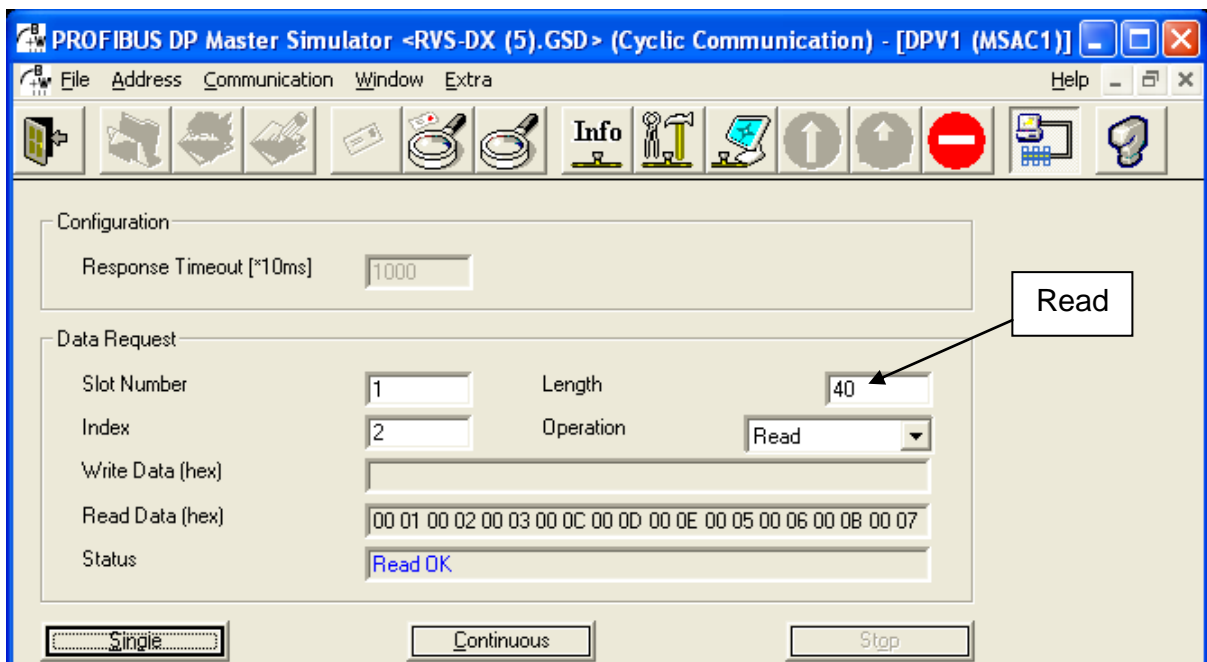

Figure 35: Reading the register number that shown in the DPV0 (cyclic) list

8.7.4 Operations that are Available in DPV1

- Choose the registers that will display at DPV0 (cyclic). This is described in section 8.7.3.3.2 on page 119.
- Read and write from a random registers.

8.7.4.1 Read and Write from Random Registers by Data Request

Reading or writing by Data Request (DPV1) allows reading or writing a group of up to 20 registers in a single cycle. However, these registers must be listed consecutively in section 8.7.7 Actual Data Register Numbers (Decimal) on page 123.

In other words, registers 2 through 18 can be read in a single cycle, but two different cycles are required to read registers 4 and 9 without reading registers 5 through 8.

The cycle of reading or writing through Data Request (DPV1) is defined in two steps.

Step 1: Define the number of the first register to read or write.

Step 2: Edit the number of registers that follow.

For example, to read registers 2 through 18, you define register **2** as the first register to read and **16** as the number of registers that follow.

The length of the register number must always contain two bytes (1 word), therefore the register 0x80 is defined as 00 80.

8.7.4.1.1 Sample Data Request to Read Registers 2 Through 6

In this example, the register to read is 0x80.

- Step 1: Configure the number of the first register to read.
 Enter **2** into the Slot Number field and the Index field.
 Enter **00 80** to define the starting register as 0x80.

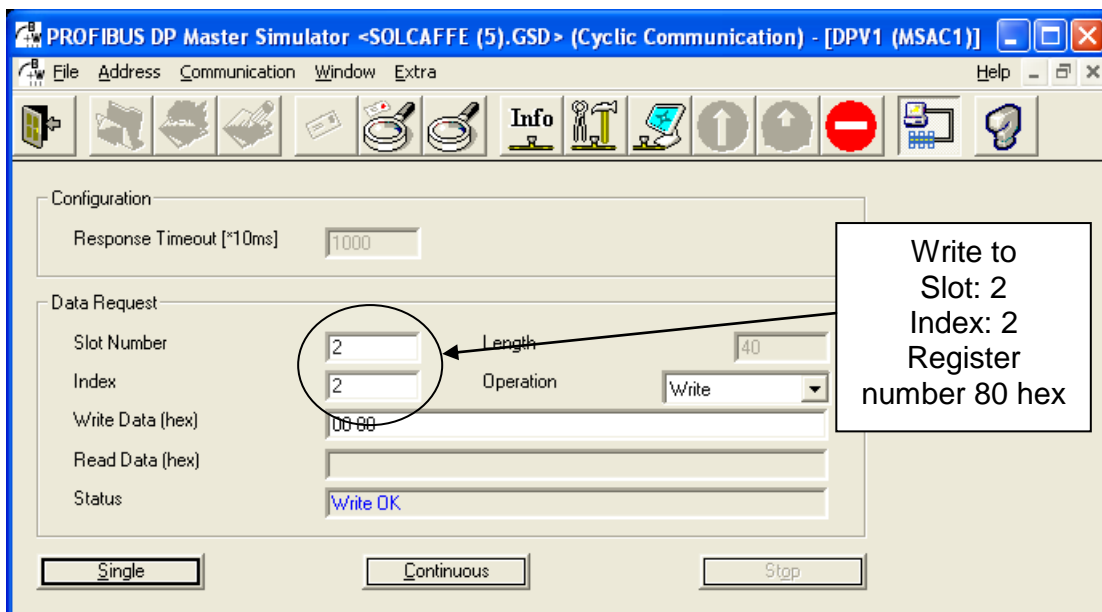

Figure 36: Choosing register number 80 hex

- Step 2: Configure the number of registers that follow.
 Enter **3** into the Slot Number field.
 Enter **2** into the Index field.
 Enter **8** into the Length field.

The length is 8 because there are a total of 4 registers to be read, each of which contains 2 bytes (or 1 word).
 $4 * 2 = 8$,

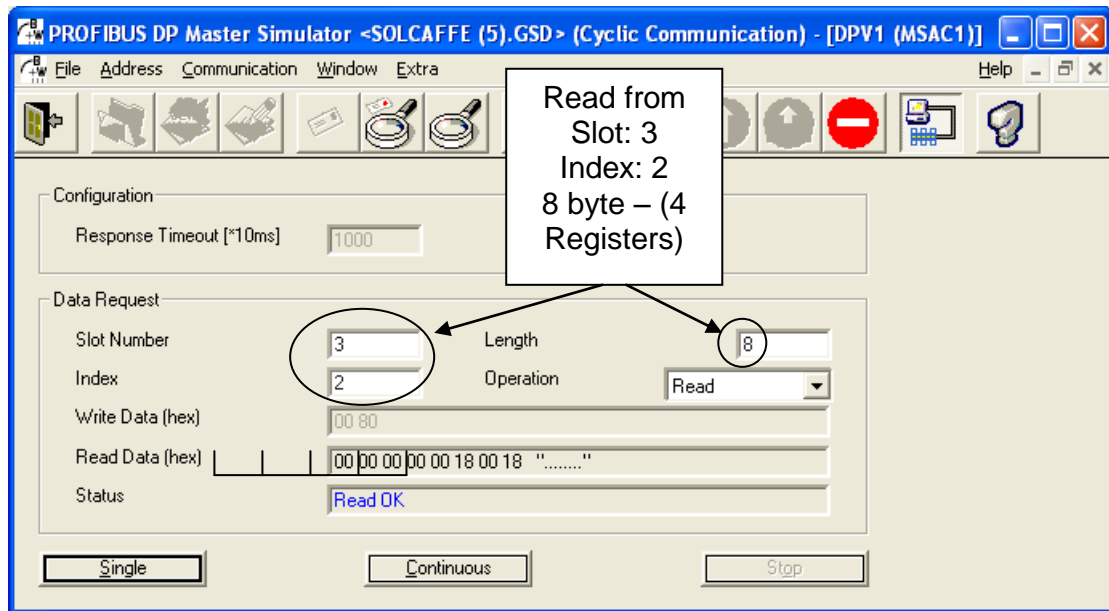

Figure 37: Reading 4 following register by Data Request (DPV1)

8.7.5 Configure PROFIBUS in the iStart

All the setting parameters to establish PROFIBUS communication are under Comm option menu. There are 5 steps to configuring the PROFIBUS.

1. Press the **Down** key until the following message appears:

```
COMM OPTION
- ** PROFIBUS ** -
```

2. Press the **Enter** key once to cause the following message to appear:

```
SERIAL LINK NO.
ENABLE
```

This selection allows control through PROFIBUS.

3. Press the **Down** key once to cause the following message to appear:

```
COM CHANGE PARAM
YES
```

4. Select YES to enable parameters to be sent via Profibus. Select NO to prevent Profibus from sending parameters.

5. Press the **Down** key a second time to cause the following message to appear:

```
CMD VIA COMM
YES
```

6. Select YES to enable commands like STOP/START to be sent via Profibus. Select NO to prevent Profibus from sending these commands.

8.7.6 Watch Dog Definition

The Watch-Dog mechanism enables and disables the PROFIBUS controller to exercise sole control over iStart.

When the Watch-Dog is enabled, the iStart will stop the motor when the communication between the controller and the device is cut.

8.7.7 *Actual Data Register Numbers (Decimal)*

Register Number	Parameter Name	Description
1	Logic Status	Logic status of iStart. 1 indicates: d15: iStart Tripped. d14: Motor Stopped. d13: Motor in Soft Stop Process. d12: Motor in Start Process. d11: Motor is Running. d10: Adjust number LSB d9: Adjust number MSB d8: Motor is running at Slow Speed forward. d7: Motor is running at Slow Speed reverse. d6: Insulation Alarm (Optional) d5..d0: Reserved
2	Current	Current, % FLA
3	Voltage	Line voltage, Volts
4	Phase Sequence	1: Correct phase seq. 0: Wrong phase seq.
5	Hardwired inputs	Discrete Hardwired control inputs: d15..d3: Reserved. d2: Logic input #3 status – 1: Active, 0: Inactive. d1: Logic input #2 status – 1: Active, 0: Inactive. d0: Logic input #1 status – 1: Active, 0: Inactive.
6	Relays	Relays status d15..d2: Reserved. d1: Relay #2 status – 1: Active, 0: Inactive. d0: Relay #1 status – 1: Active, 0: Inactive.
7	Insulation Resistance	Motor insulation, Kohm (Optional).
8	I Zero Current	Ground leakage current, % FLA
9	I Motor Unbalanced Current	Max current deviation between phases, %
10	Frequency	Main frequency, Hz
11	Thermistor Resistance	Thermistor resistance, tenth Kohm (Optional).
12	Power [Watt] – Low word	Power modulo 64K (65536)
13	Power [Watt] – High word	Power divided by 64K (65536) without residue
14	Power Factor	Power Factor * 100
15	Total run time [Sec] – Low word	Total Motor runtime modulo 64K (65536)
16	Total run time [Sec] – High word	Total Motor runtime divided by 64K (65536) without residue
17	Logic status at power fail	Logic status at control power supply turns off.
18	Total run time	Total hours of running motor.

Register Number	Parameter Name	Description
19	Total starts	Total number of starts
20	Last start period	Duration of last start, Seconds
21	Last start peak I	Peak current during last starting process
22	Time to Re-Enable start [Sec]	Wait time until next start command will be allowed
23	Total trips	Total number of trips
24	Last trip number	<p>Code number of the fault that caused trip</p> <p># Fault</p> <p>01: Over Temperature</p> <p>02: Short Circuit Current</p> <p>03: Overload</p> <p>04: Under Current</p> <p>05: Under Voltage</p> <p>06: Over Voltage</p> <p>07: Phase Loss</p> <p>08: Phase Sequence</p> <p>09: Shorted SCR or Wrong Connection.</p> <p>10: Long Start Time</p> <p>11: Slow Speed Time</p> <p>12: MODBUS Timeout</p> <p>13: External Fault</p> <p>14: Wrong Parameters</p> <p>15: COM Port Failed</p> <p>16: Too Many Starts</p> <p>17: Motor Insulation (Optional)</p> <p>18: Thermistor. (Optional)</p> <p>19: Wrong Frequency</p> <p>20: No Voltage</p> <p>21: Over 7.5 * FLA current</p> <p>22: Over 7.5 * FLC current</p> <p>23: Motor Unbalance</p> <p>24: Ground Fault</p> <p>25: No Current</p> <p>26: No Control power</p> <p>27: Over Current (Inverse)</p> <p>28: Shear pin current</p> <p>29: Wrong VZC</p> <p>30: Welded contactor</p> <p>31: By pass fault</p>
25	Pre trip I	Current at trip time, Amp.
26	Logic Input Status	
27	Version CRC16	The unique CRC16 Calculation of each SW Version

Register Number	Parameter Name	Description
28	Phase Sequence	1: Positive, 0: Negative
29	Time to Over Current Trip	Time left until "Over Current" trip occurs in seconds
30	Cos Phi	Cos Phi * 100
31	Phase 1 Voltage	Phase 1 voltage, % Rated Line Voltage * 10
32	Phase 2 Voltage	Phase 1 voltage, % Rated Line Voltage* 10
33	Phase 3 Voltage	Phase 1 voltage, % Rated Line Voltage* 10
34	Phase 1 Current	Phase 1 current, % FLA * 10
35	Phase 2 Current	Phase 1 current, % FLA * 10
36	Phase 3 Current	Phase 1 current, % FLA * 10
37	Energy [KWH] – Low word	Total Energy modulo 64K (65536)
38	Energy [KWH] – High word	Total Energy divided by 64K (65536) without residue
39	Energy per cycle – first word – MSB	Energy per cycle in Watts
40	Energy per cycle – second word	
41	Energy per cycle – third word	
42	Energy per cycle – forth word – LSB	
43	Reserved	
44		
45		
46		
47		
48	Analog option card – Temperature 1	Thermistor or phase 1 RTD Temperature (Analog option cards) [Kelvin]
49	Analog option card – Temperature 2	Thermistor or phase 2 RTD Temperature (Analog option cards) [Kelvin]
50	Analog option card – Temperature 3	Thermistor or phase 3 RTD Temperature (Analog option cards) [Kelvin]
51	Reserved	
52		
53	Phase 1 Temperature	Phase 1 internal temperature. [Kelvin]
54	Phase 2 Temperature	Phase 2 internal temperature. [Kelvin]
55	Phase 3 Temperature	Phase 3 internal temperature. [Kelvin]
111-120	Previous Trips	Trip number of 10 last trips – from last to earliest.

8.7.8 Default Order of Register Numbers

Order	Register Number	Parameter Name
1	1	Logic Status
2	2	Current

Order	Register Number	Parameter Name
3	3	Voltage
4	5	Hardwired inputs
5	11	Thermistor Resistance
6	7	Insulation Resistance
7	10	Frequency
8	4	Phase Sequence
9	6	Relays
10	18	Total run time
11	19	Total status
12	20	Last start period
13	21	Last start peak I
14	22	Time to Re-Enable start [Sec]
15	23	Total trips
16	24	Last trip number
17	25	Pre trip I
18	26	Reserved
19	39	Energy per cycle – first word – MSB
20	40	Energy per cycle – second word – MSB

8.7.9 Setting Parameters for Data Request

8.7.9.1 Main Parameters

Parameter	#	Range	Default
Rated Line	0	1..600 V	400 V
Phase Sequence	1	0 – Ignore 1 – Positive 2 - Negative	0 – Ignore
FLC	2	17..1100 A	44 A
Motor rated power	3	1..3000 KW	35 KW
Reserved	4		
	5		
O/C Shear Pin	6	100..850 (% of FLA)	400 (% of FLA)
Reserved	7		
Overload Class	8	IEC5..NEMA60	IEC10
Overload Protect	9	0 – Disable 1 – Enable while run 2 – Enable always	0 – Disable
Under Current Level	10	0..90 (% of FLA)	20 (% of FLA)
M.Unbalance Current Level	11	10..100 (% of FLA)	20 (% of FLA)
Ground Fault Current Level	12	1..60 (% of FLA)	20 (% of FLA)
Under Voltage Level	14	50..90 (% of Rated Line)	75 (% of Rated Line)

8.7.9.2 Start Parameters

Parameter	#	Range	Default
Soft_Start_Curve	24	0..10 (5..9 are for Tacho only)	0 (Standard).
Pulse_Time	25	0..10 (Tenth Seconds)	0 (No Pulse)
Initial_Voltage / Current	26	10..80	30 (% of full voltage)
Current_Limit	27	100..500	400 (% of FLA)
Acceleration_Time	28	1..90	10 (Seconds)
Max_Start_Time	29	1..250	30 (Seconds)
Number_Of_Starts	30	1..10 & (11 = off)	10
Starts_Period	31	1..60	30 (Minutes)
Start_Prevent_Time	32	1..60	15 (Minutes)
Run_Contact_Delay	33	0..40	5 (Seconds)
Reserved	35..39		

8.7.9.3 Stop Parameters

Parameter	#	Range	Default
Soft_Stop_Curve	40	0..10 (5..9 are for Tacho only)	0 (Standard)
Deceleration_Time	41	1..30	10 (Seconds)
Final_Torque	42	0..10	0 (Minimum)
Reserved	43..47		

8.7.9.4 Dual Adjust Parameters

Parameter	#	Range	Default
Dual_Adj_Init_Voltage	48	10..80 % of full voltage	30
Dual_Adj_Current_Limit	49	100..500	400 % of FLA
Dual_Adj_Acc_Time	50	1..90	10 (Seconds)
Dual_Adj_Dec_Time	51	1..30	10 (Seconds)
Dual_Adj_Motor_FLA	52	5..1400	105 (Amp.)

Reserved	53..55		
----------	--------	--	--

8.7.9.5 Energy Save & Speed Parameters

Parameter	#	Range	Default
Energy_Save	56	1..10	10 (Max Save)
Slow_Speed_Torque	57	1..10	8
Max_Slow_Speed_Time	58	1..250	30 (Seconds)
Reserved	59..62		

8.7.9.6 Fault Parameters

Parameter	#	Range	Default
Phase_Loss Y/N	63	0..1	0 (No)
Phase_Sequence Y/N	64	0..1	0 (No)
Insulation_Alarm	65	1..50 Tenth Mohm 0.2..5 M	1 (Off)
Insulation_Trip	66	1..50 Tenth Mohm 0.2..5 M	1 (Off)
Auto_Reset	67	0 / 1 (0 - No, 1 - Yes)	0 (No)
Thermistor_Type	68	0 / 1 (0 - PTC, 1 - NTC)	0 (PTC)
Thermistor_Trip	69	0..100 Tenth Kohm 0.1..10 K	0 (Off)
Under_Current_Reset	70	10..120 (&121=off)	121 (Off)
Reserved	71		

8.7.9.7 I/O Programming

Parameter	#	Range	Default
Prog. Input #7 (thermal7)	72	0..2(0=En.Save,1=S.Spd,2=Rst)	2 (Energy Saver)
Prog. Input #8 (thermal8)	73	0..2(0=D.Adj.,1=Rvrs,2=Rst)	0 (Dual Adjust)
Fault_Relay_Type	74	0..1 (0=Fault, 1=Fault-Fail Safe)	0 (Fault)
Immediate_Realy_Type	75	0..1 (0=Immediate, 1=shear pin)	0 (Immediate)
Imm._Realy_On_Delay	76	0..3600	0 (Seconds)
Imm._Realy_Off_Delay	77	0..3660	0 (Seconds)
Analog Output Parameter	78	0 - Current, 0..200% of motor fla	0 (Current)
Reserved	79		

9. INSTALLING A FAN ON SIZE A, B AND C

Step 1: Disconnect the mains and control power from the iStart.

Step 2: Remove the iStart unit from the wall.

Step 3: Mount the fan on the wall instead of the iStart unit. Use the same holes.

Step 4: Mount the iStart unit on fan using the same screws that you removed in step 2.

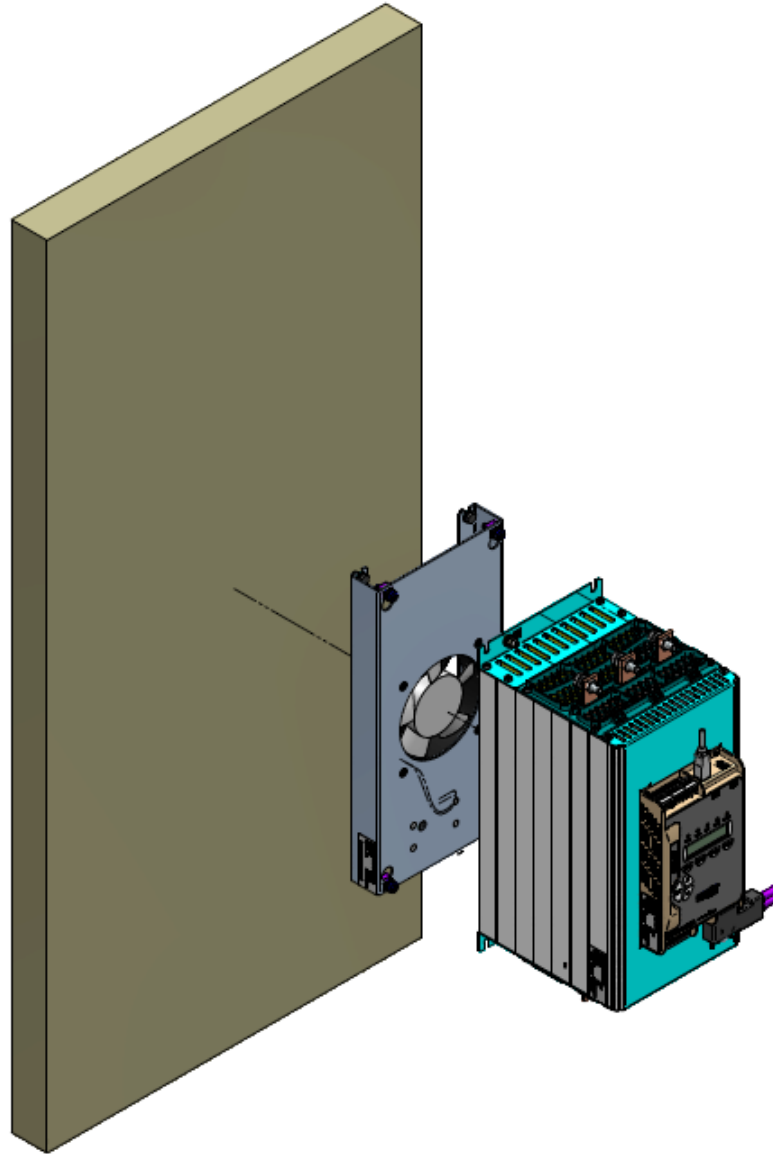

Figure 38: Installing a fan (sizes A, B and C)

Step 5: Connect power to the fans. Refer to Figure 39 – connect **LINE** to **AC1**, **NEUTRAL** to **AC2**.

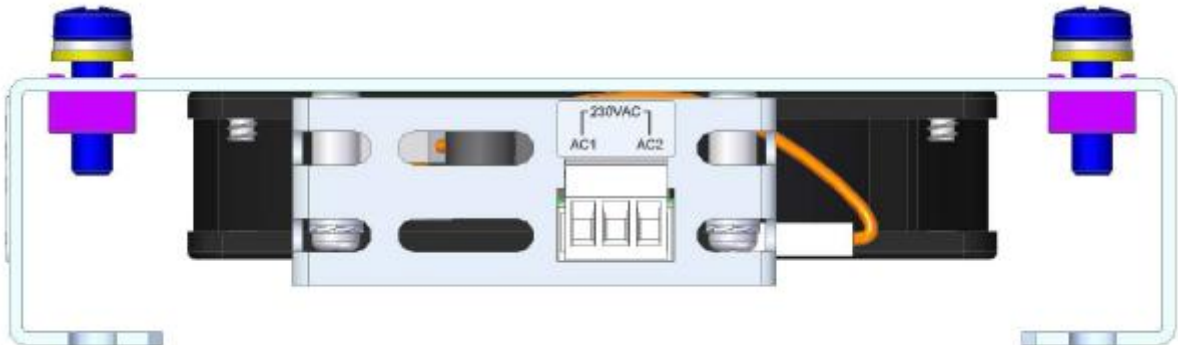

Figure 39: Fan power connection

Step 6: Reconnect mains and control power to iStart.

10. TROUBLESHOOTING

Upon fault – motor stops, *Fault* LED lights and Fault Relay operates. The LCD shows TRIP: and fault description. (for example: TRIP: UNDER CURRENT).

Fault Message	Cause and Troubleshooting
TOO MANY START	<p>Trips the starter if number of starts, during START PERIOD exceeds the preset number.</p> <p><i>Wait until motor and starter cool down – according to START INHIBIT setting. For more information on adjusting START PERIOD and START INHIBIT refer to section 6.6.2 on page 58.</i></p>
LONG START TM	<p>Trips the starter if output voltage does not reach nominal at the present MAX. START TIME.</p> <p><i>Check FLA, FLC, and MAX START TIME settings. Increase INITIAL VOLTAGE, CURRENT LIMIT & MAX. START TIME or decrease ACCELERATION TIME as necessary. For more information on FLC & FLA refer to section 0 on page 45 (MAIN PARAMETERS). For more information on adjusting START PARAMETERS refer to section 6.6.2 on page 58.</i></p>
SHEAR PIN CURR or O/C SHEAR PIN	<p>Trips the starter when:</p> <ul style="list-style-type: none"> Instantaneously when current exceeds 8.5 x Starter FLC (not programmable). During starting when current exceed 8.5 x Motor FLA (not programmable). During running when current exceeds 100-400%, or 100-850% with EXTEND SETTING (programmable value). <p>O/C Shear-Pin has a programmable delay of 0-5 seconds where the starter detects the fault and does not trip before time delay has elapsed (delay is override when current reaches 8.5 x Starter FLC).</p> <p><i>Check that motor is not installed or Jammed. Check FLA, FLC settings. Check motor and cable connections. Perform a “Megger” test to verify motor and cable’s condition. For more information on FLC, FLA & O/C – SHEAR PIN refer to section 0 on page 45 (MAIN PARAMETERS).</i></p>
OVERLOAD	<p>Trips the starter when current exceed the OVERLOAD TRIP level and thermal register has filled up.</p> <p><i>Check FLA, FLC and Overload settings, check motor current, wait 15 minutes to let motor and starter cool down before restarting. For more information on FLC, FLA & OVERLOAD settings refer to section 0 on page 45 (MAIN PARAMETERS).</i></p>
UNDER CURRENT	<p>Trips the starter when line current drops below the preset level for the preset time.</p> <p><i>Check UNDER CURRENT TRIP and TIME DELAY settings, check line currents through L1, L2, L3. For more information on UNDER CURRENT settings refer to section 0 on page 45 (MAIN PARAMETERS).</i></p>

CAUTION

Check that “Megger” maximum voltage is no more than 500V !!

Fault Message	Cause and Troubleshooting
UNDER VOLTAGE or NO VOLTAGE	<p>Trips the starter when line voltage drops below the preset level for the preset time.</p> <p><i>Check UNDER VOLTAGE TRIP and TIME DELAY settings, check line voltages on L1, L2, L3. When voltage drops to zero, the starter trips immediately with no delay. For more information on UNDER VOLTAGE settings refer to section 0 on page 45 (MAIN PARAMETERS).</i></p>
OVER VOLTAGE	<p>Trips the starter when line voltage increases above a preset level for a preset time.</p> <p><i>Check OVER VOLTAGE TRIP and TIME DELAY settings, check line voltage on L1, L2, L3. For more information on OVER VOLTAGE settings refer to section 0 on page 45 (MAIN PARAMETERS).</i></p>
PHASE LOSS	<p>Trips the starter if 1 or 2 phases are missing.</p> <ul style="list-style-type: none"> • <i>Check voltages are within the required range voltages and frequency is within the range of 45-65Hz.</i> • <i>If all previous actions are do not solve the problem and the you are sure that no real phase loss exists, you can set PHASE LOSS Y/N protection to NO. This situation can occur in rare cases when there is no real fault but the iStart recognizes unusual behaviour like when Total Harmonic Distortion in Voltage (THDV) in the network is high.</i> • <i>If this is a true case of PHASE LOSS then after setting PHASE LOSS Y/N protection to NO the motor will single phase and most likely be tripped by the over load protection mechanism.</i> • <i>Phase loss might not be detected in motor operating under a light load.</i> <p><i>For PHASE LOSS protection setting refer to section 6.6.3.2 on page 66.</i></p>
PHASE SEQUENCE	<p>Trips the starter if line phase sequence is wrong.</p> <p><i>Check line phase sequence, and if wrong, swap two wires on line side. If motor now rotates in the wrong direction, swap two wires on load side.</i></p>
SHORT CIRCUIT	<p>Trips the soft iStart when connected Inside Delta and Wrong connection or if over current is detected by the iStart.</p> <p><i>Verify that the motor is not stalled or shorted and check cables and wiring. Verify that motor and iStart are connected exactly as shown in section 3.7.7.2 page 19. If circuitry is 100% confirmed it is possible to start when EXTEND SETTING are ENABLED. Refer to section 6.6.3.1 on page 56. If a fault occurs again consult the factory. The operator is advised to try operating one time only. Note that it is useless to try starting in this mode more than once.</i></p>

Fault Message

Cause and Troubleshooting

S. SCR OR WR. CONNECTION	<p>Trips the starter when one or more motor phases are not properly connected to starter's load terminals, in case of internal disconnection in motor winding or if any SCR is short-circuited or when motor windings are shorted.</p> <p><i>Check with an ohmmeter between L1-U, L2-V, L3-W; resistance > 20 KΩ. Check for no voltage on terminals U, V, W (from parallel system or an independent bypass). SCRs may fail due to:</i></p> <ul style="list-style-type: none"> ▪ <i>High short current not protected by proper fuses</i> ▪ <i>High voltage spikes not protected by proper external varistors.</i> ▪ <i>Frequent starting at maximum conditions or fault conditions.</i> <p><i>If required, may be eliminated by using generator mode (programming AUX. IN PROG INPUT parameters accordingly) For more information on programming AUX. IN PROG INPUT refer to section 6.6.6 on page 75 (I/O PROGRAMMING PARAMETERS).</i></p> <p>Note: <i>Shorted SCR and Wrong Connection faults are not active in Generator mode.</i></p>
HS OVR TMP	<p>Heat-sink over-temperature. Trips the starter when heat-sink temp. rises above 85°C.</p> <p><i>Check that motor starting is not too frequent.</i></p>
EXTERNAL FAULT	<p>Trips the starter when a N.O contact between Aux. input terminals 13, 14 closes for over two seconds.</p> <p><i>Check contact position and cause of closure. For more information on programming AUX. IN PROG INPUT refer to section 6.6.6 on page 75 (I/O PROGRAMMING PARAMETERS).</i></p>
SLOW SPEED TM	<p>Slow speed time is exceeded.</p> <p><i>Check the settings of MAX SLOW TIME. For more information on programming MAX SLOW TIME refer to section 0 on page 64 (SPECIAL FEATURES PARAMETERS).</i></p> <p>Note: <i>Motor and iStart may be overheated when operating at slow speed for an extended period.</i></p>
WRONG PARAMS	<p>Parameters not transferred from RAM to EEPROM or vice versa. After replacing the EPROM with a new software version or after power up.</p> <p><i>To solve this problem, return iStart to the default settings, then reprogram it with all of the settings that you had before the fault occurred. (If Fault LED is on, press Reset after WRONG PARAMETERS).</i></p>
WRONG FREQUENCY	<p>Trips the soft starter when mains voltage frequency is not within the limits of 45-65Hz.</p> <p><i>Check mains frequency.</i></p>
BYPASS FAULT	<p>Trips the starter Control Voltage is too high or too low.</p> <p><i>Check Control voltage. Contact factory if fault is repeated.</i></p>

10.1 Blank RMA Form

Return Material Authorization Form-“RMA” - Fault Report – Non/ Warranty Claim

After Sales Service Department

E-mail: tech.support@solcon.com Tel. + 972 – 77-7711130, 972-77-7711123 Fax. + 972 – 77-7711140

Equipment Model:			
Equipment Serial no.:			
Report date			
Date of equipment sale		Date of installation	
Representing Firm			
Contact person			
Telephone number		Fax number	
Email address			
Application			
Starter Rating			
Motor current rating (motor Label)			
Number of starts per hour			
Special installation / ambient factors (°C)			
Type of Fault Reported & time of occurrence (during start, after start, during soft stop, end of soft stop, ON B.P. closing, when ...			
Last Start Period		Total Number Of Trips	
Last Start Max. I		Starter FLC	
Total Run Time		Motor FLC	
Total Number Of Starts		Initial Voltage	
Last Trip		Acceleration Time	
Trip Current		Current Limit	
Remarks			
By Distributor: We declare that product has been correctly applied, installed and operated, in accordance with Solcon's written instructions, appropriate codes, regulations and good practice, within the limits of rated capacity and normal usage.			Warranted repair/replacement

To be completed By Solcon Service Dept.:

Return Material Authorization Number		
Date		
Authorized by		

11. TECHNICAL SPECIFICATIONS

Supply Voltage	Line to Line 208-600V (to be specified) + 10%-15% for all models
Frequency	45 – 65 Hz (Fixed or variable frequency source)
Control Supply	115V or 230V (to be specified) +10% - 15%
Load	Three phases, three wires, squirrel cage induction motor.

Start-Stop Parameters:

Starter FLC	Starter's Full Load Current, according to Selector Guide
Motor FLA	Motor Full Load Ampere 50-100% of Starter FLC (Full Load Current).
Pump and Torque Control Curves	Field selectable curves preventing Over-pressure during start and Water Hammer during stop.
Pulse Start Duration	A pulse of 80% Un, adjustable range 0.1-1 Sec, for starting high friction loads.
Initial Voltage,	5-80% Un
Initial Current	100-400% of Motor FLA
Current Limit	100-500% of Motor FLA
Acceleration Time	1-90 Sec
Deceleration Time	1-90 Sec

Motor Protection:

Too Many Starts	Maximum number of starts, range: Off or 1-10, during a time period 1-60 min.
Starts inhibit	Period of 1-60 min, during which starting is prevented, after Too Many Start fault.
Long Start Time (Stall protection)	Maximum allowable starting time 1-30 sec. (1-250sec. in EXTEND SETTING)
Over Current (Shear-pin)	Two operation functions: during starting trips the starter at 850% and during running at 100-850% In, both within 1 Cycle (after internal delay).
Electronic Overload (I ² t)	Adjustable IEC and MEMA curves.
Under Current	Trips when current drops below 20-90% In, time delay 1-40 sec.
Under Voltage*	Trips when main voltage drops below 50-90%, time delay 1-10 Sec
Over Voltage	Trips when main voltage increase above 110-125%, time delay 1-10 sec.
Phase Loss, Under/Over Frequency*	Trips when one or two phases are missing and frequency is 45Hz. or 65Hz.
Phase Sequence	Trips when phase sequence is wrong
Shorted SCR or Wrong connection	Prevents starting, trips if motor is not connected / incorrectly connected to the starter, or in case one or more SCRs have been shorted
Heat Sink Over temp	Trips when heat-sink temperature rises above 85°C.
External fault	Trips when an External Contact closes for 2 sec.
* With optional Auto Reset.	

Control:

Displays	LCD in 4 – Field selectable languages and 4 LEDs.
Keypad	6 keys for easy setting
R1, R2	2 Contacts, 8A, 250VAC, 2000VA

Temperatures:

Operating -10° to 50°C. For higher ratings consult factory.
Storage -20° to 70°C

Standards:

Dielectric Test	2500VAC
Degree of Protection	IP 20 for frame size D1, IP 00 for frame sizes D2-D5
EMC Emissions	EN 55011 CISPR 11 Class A
Immunity	EN 55082-2 ESD 8KV air, IEC 801-2 Electric RF field 10 V/m, 20-1000MHz, IEC 801-3 Fast transients 2KV, IEC 801-4
Safety	EN 600947-1 Related to safety requirements. Designed and assembled to conform with UL508C

Normal Service Conditions:

Altitude Up to 1000m. For equipment to be used at higher altitudes consult Factory.
Humidity 95% at 50°C or 98% at 45°C.

Control Power Consumption

The approx. consumption of iStart soft starters is as follows:

Model	Electronic	Fan Module Consumption
44	35VA	50VA
85	35VA	50VA
170	35VA	50VA
230	95VA	110VA
310	95VA	110VA
350	95VA	110VA
430	95VA	110VA
515	95VA	110VA
590	95VA	110VA
690	95VA	110VA
720	95VA	110VA
850	95VA	110VA
960	95VA	110VA
1100	95VA	110VA

